



# F1100-90

## FLOOR DRAIN WITH SIDE OUTLET FOR NON-MEMBRANE FLOOR AREAS

Internet address: [www.mifab.com](http://www.mifab.com)

Toll Free: 1-800-465-2736

Canada Toll Free: 1-800-387-3880

**SPECIFICATION:** MIFAB Series F1100-90-( )-1 lacquered cast iron floor drain with anchor flange, weepholes, threaded side outlet and standard reinforced (specify diameter), satin finished nickel bronze strainer. (For membrane floors, use MIFAB F1100C-90 Series).

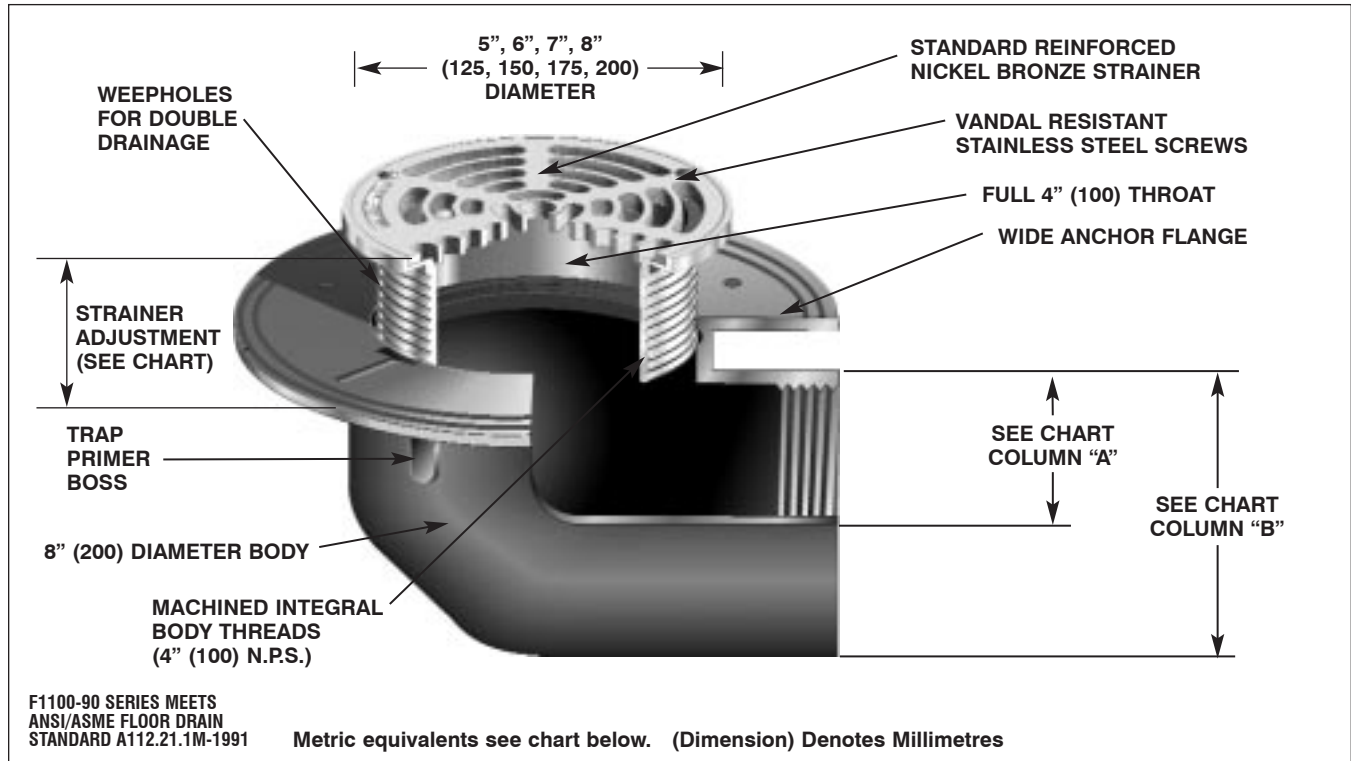

STRAINER DIAMETER	STRAINER ADJUSTMENT		ANSI/ASME RATING		PIPE SIZE	BODY HEIGHT	
	MIN	MAX	FREE AREA	LOAD RATING N.B. (-1) D.I. (-4)		A	B
5" (125)	1/2" (13)	1 1/2" (38)	8 in <sup>2</sup> (5200 <sup>2</sup> )	UP TO 2,000 LBS. UP TO 7,499 LBS.	2" (50) 3" (75)	2 1/2" (63) 3 1/2" (89)	4 3/8" (111) 4 3/8" (111)
6" (150)	11/16" (17)	1 1/2" (38)	9 in <sup>2</sup> (5800 <sup>2</sup> )	UP TO 2,000 LBS. —			
7" (175)	9/16" (14)	1 9/16" (40)	12 in <sup>2</sup> (7700 <sup>2</sup> )	UP TO 2,000 LBS. —			
8" (200)	11/16" (17)	2 1/4" (57)	18 in <sup>2</sup> (11600 <sup>2</sup> )	UP TO 2,000 LBS. OVER 10,000 LBS.			

### OPTIONAL VARIATIONS:

- Nickel bronze (standard)
- Stainless steel strainer**
- 3M epoxy finish
- Ductile iron grate (5", 8" only)
- Sediment bucket
- Vandal proof
- Trap seal primer tapping

- suffix -1
- suffix -3**
- suffix -3M
- suffix -4
- suffix -5
- suffix -6
- suffix -7

- Backwater valve
- Acid resistant epoxy coating
- All galvanized
- Extension
- Closure plug
- Lacquered cast iron funnels
- Client logo
- 4" Round funnel
- 6" Round funnel
- Oval 4" x 9" funnel
- 6" x 3" x 1" funnel
- No hub side outlet
- Elastomeric flange

- suffix -8
- suffix -11
- suffix -13
- suffix -15
- suffix -34
- suffix -50
- suffix -95
- suffix -F4
- suffix -F6
- suffix -G
- suffix -J
- suffix -NH
- suffix -Z

### PARTS:



A1-90



STANDARD (STRAINER SIZE) -1