



F1100C-EG

OVAL FUNNEL FLOOR DRAIN FOR MEMBRANE FLOOR AREAS

Internet address: www.mifab.com

Toll Free: 1-800-465-2736

Canada Toll Free: 1-800-387-3880

SPECIFICATION: MIFAB Series F1100C-EG-1 lacquered cast iron floor drain with anchor flange, cast iron membrane clamp ring with primary and secondary weepholes for waterproofing membrane, and standard 4" (100) x 9" (230) oval satin finished nickel bronze open throat funnel. (For non-membrane floors, use MIFAB F1100-EG Series).

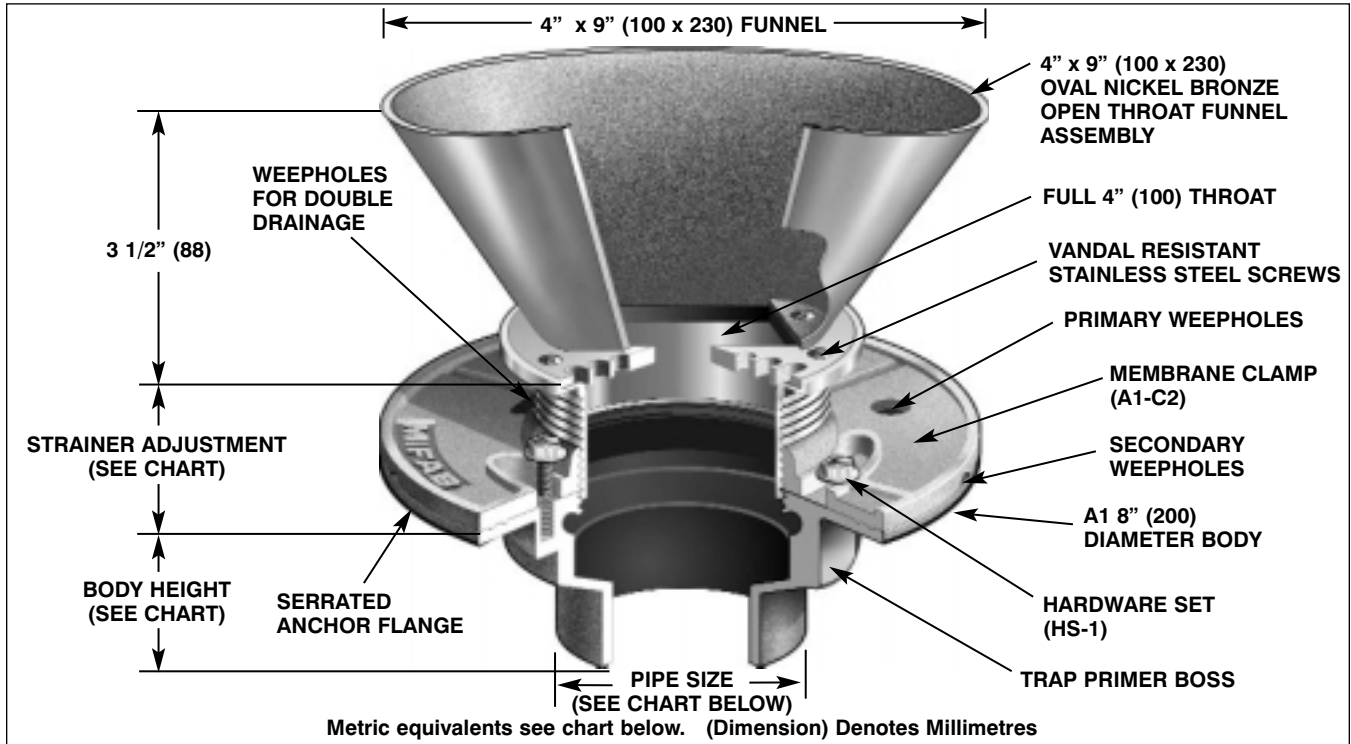

STRAINER DIAMETER	STRAINER ADJUSTMENT		PIPE SIZE	NO HUB	BODY HEIGHT PUSH ON (P)	THREADED (T)	INSIDE CAULK (X)
	MIN	MAX					
5" (125)	1 9/16" (40)	2 11/16" (68)	2" (50)	2 3/4" (70)	3 3/8" (86)	2 1/4" (57)	2 3/4" (70)
			3" (75)	2 3/4" (70)	3 3/8" (86)	2 5/8" (67)	2 3/4" (70)
			4" (100)	2 3/4" (70)	3 3/8" (86)	2 5/8" (67)	2 3/4" (70)
			6" (150)	3 1/4" (83)	—	—	—

OPTIONAL VARIATIONS:

- Nickel bronze (standard)
- Stainless steel strainer and funnel**
- 3M epoxy finish
- Sediment bucket
- Vandal proof
- Trap seal primer tapping
- Backwater valve
- Acid resistant epoxy coating
- All galvanized
- Extension
- Bronze body
- Stainless steel body (type 304)

- suffix -1
- suffix -3
- suffix -3M
- suffix -5
- suffix -6
- suffix -7
- suffix -8
- suffix -11
- suffix -13
- suffix -15
- suffix -27
- suffix -28

- Stainless steel body (type 316)
- PVC socket connection body**
- ABS socket connection body**
- Closure plug
- Deck clamp
- Sump receiver
- Lacquered cast iron funnel
- Threaded side outlet
- Clamp ring for low rough-in (min. 1/2" (13))
- Push on outlet
- Threaded outlet
- Inside caulk outlet
- Elastomeric flange
- suffix -29
- suffix -30
- suffix -31
- suffix -34
- suffix -40
- suffix -41
- suffix -50
- suffix -90
- suffix C1
- suffix P
- suffix T
- suffix X
- suffix Z

PARTS:

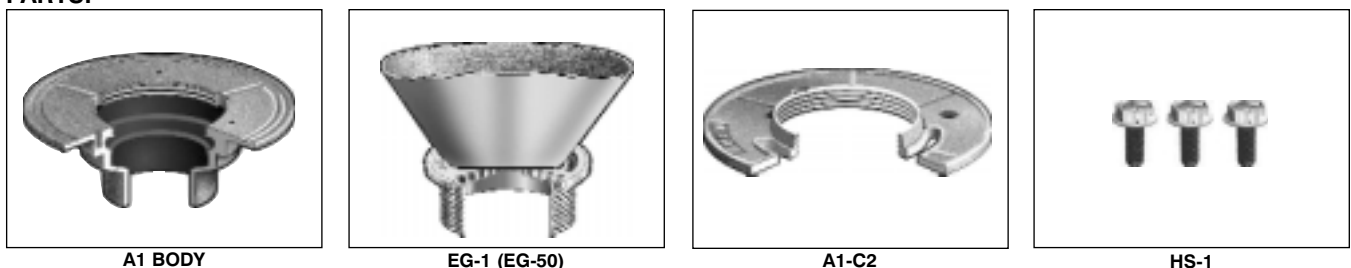

A1 BODY

EG-1 (EG-50)

A1-C2

HS-1