



# F1100C-ER

## EXTENDED RIM FLOOR DRAIN FOR MEMBRANE FLOOR AREAS

Internet address: [www.mifab.com](http://www.mifab.com)

Toll Free: 1-800-465-2736

Canada Toll Free: 1-800-387-3880

**SPECIFICATION:** MIFAB Series F1100C-ER( )-1 lacquered cast iron floor drain with anchor flange, cast iron membrane clamp ring with primary and secondary weepholes for waterproofing membrane, and extended rim (specify diameter), satin finished nickel bronze strainer. (For non-membrane floors, use MIFAB F1100-ER Series).

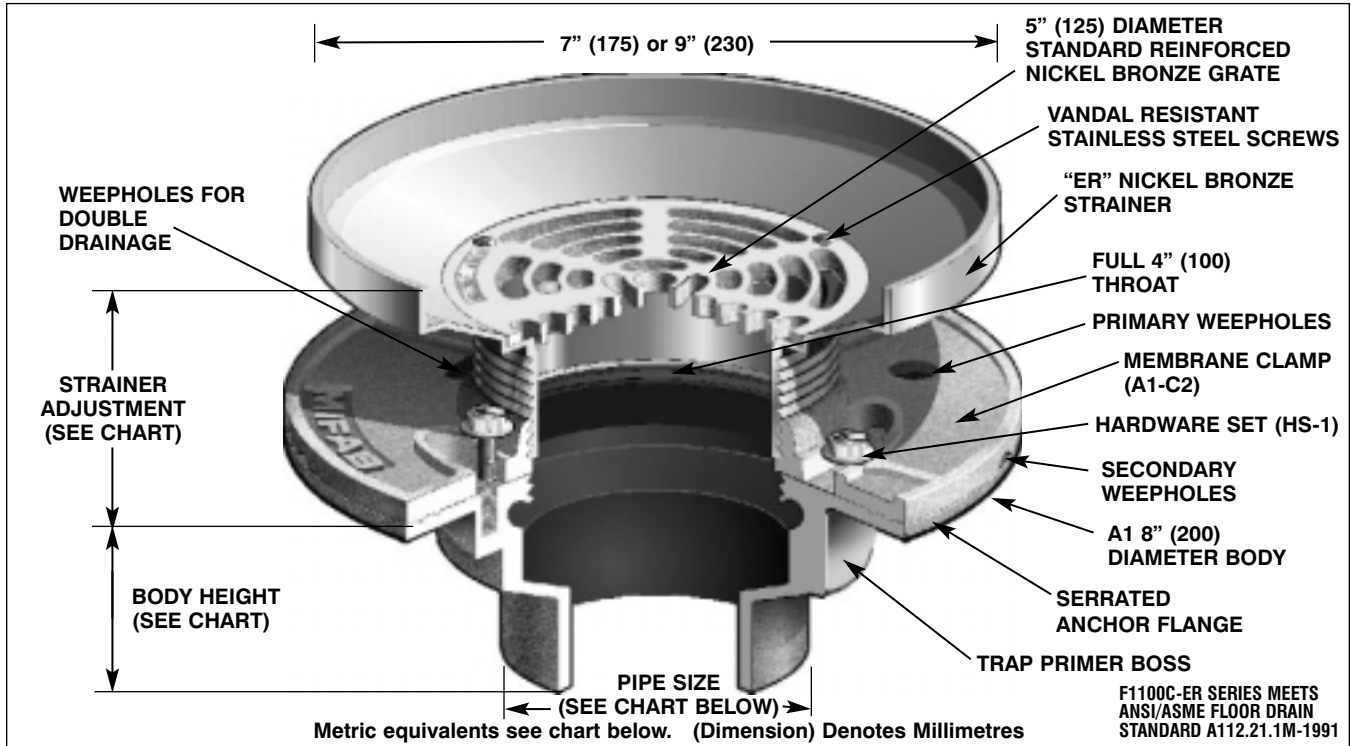

STRAINER DIAMETER	STRAINER ADJUSTMENT		PIPE SIZE	NO HUB	BODY HEIGHT PUSH ON (P)	THREADED (T)	INSIDE CAULK (X)
	MIN	MAX					
7" (175)	2 7/8" (73)	3 3/4" (95)	2" (50)	2 3/4" (70)	3 3/8" (86)	2 1/4" (57)	2 3/4" (70)
9" (230)	3" (75)	3 3/4" (95)	3" (75)	2 3/4" (70)	3 3/8" (86)	2 5/8" (67)	2 3/4" (70)
			4" (100)	2 3/4" (70)	3 3/8" (86)	2 5/8" (67)	2 3/4" (70)
			6" (150)	3 1/4" (83)	—	—	—

### OPTIONAL VARIATIONS:

- |   |   |   |  |
|---|---|---|--|
| <ul style="list-style-type: none"> <li><input type="checkbox"/> Nickel bronze (standard)</li> <li><input type="checkbox"/> 3M epoxy finish</li> <li><input type="checkbox"/> Sediment bucket</li> <li><input type="checkbox"/> Vandal proof</li> <li><input type="checkbox"/> Trap seal primer tapping</li> <li><input type="checkbox"/> Backwater valve</li> <li><input type="checkbox"/> Acid resistant epoxy coating</li> <li><input type="checkbox"/> All galvanized</li> <li><input type="checkbox"/> Extension</li> <li><input type="checkbox"/> Bronze body</li> <li><input type="checkbox"/> Stainless steel body (type 304)</li> <li><input type="checkbox"/> Stainless steel body (type 316)</li> </ul> | <ul style="list-style-type: none"> <li>suffix -1</li> <li>suffix -3M</li> <li>suffix -5</li> <li>suffix -6</li> <li>suffix -7</li> <li>suffix -8</li> <li>suffix -11</li> <li>suffix -13</li> <li>suffix -15</li> <li>suffix -27</li> <li>suffix -28</li> <li>suffix -29</li> </ul> | <ul style="list-style-type: none"> <li><input type="checkbox"/> PVC socket connection body</li> <li><input type="checkbox"/> ABS socket connection body</li> <li><input type="checkbox"/> Closure plug</li> <li><input type="checkbox"/> Deck clamp</li> <li><input type="checkbox"/> Sump receiver</li> <li><input type="checkbox"/> Lacquered cast iron strainer</li> <li><input type="checkbox"/> Threaded side outlet</li> <li><input type="checkbox"/> Clamp ring for low rough-in (min. 1 3/4" (44))</li> <li><input type="checkbox"/> Push on outlet</li> <li><input type="checkbox"/> Threaded outlet</li> <li><input type="checkbox"/> Inside caulk outlet</li> <li><input type="checkbox"/> Elastomeric flange</li> </ul> | <ul style="list-style-type: none"> <li>suffix -30</li> <li>suffix -31</li> <li>suffix -34</li> <li>suffix -40</li> <li>suffix -41</li> <li>suffix -50</li> <li>suffix -90</li> <li>suffix C1</li> <li>suffix P</li> <li>suffix T</li> <li>suffix X</li> <li>suffix -Z</li> </ul> |
|---|---|---|--|

### PARTS:



A1 BODY

ER STRAINER (SPECIFY SIZE, FINISH)

A1-C2

HS-1