



MIFAB® F1100-SHG

FLOOR DRAIN WITH SQUARE HINGED STRAINER FOR NON-MEMBRANE FLOOR AREAS

Specification: MIFAB® Series F1100-(*)SHG-3 (* specify strainer size) lacquered cast iron floor drain with anchor flange, weepholes, and square, hinged, heavy duty, polished stainless steel strainer. (For membrane floors, add -C to Series number).

Function: Used in showers, kitchens, restrooms and other non-membrane finished areas. Hinged grate ensures that grate is not lost during maintenance. Square adjustable stainless steel hinged strainer is used for all types of poured finished floors. Strainer will not dish or corrode and is foot friendly.

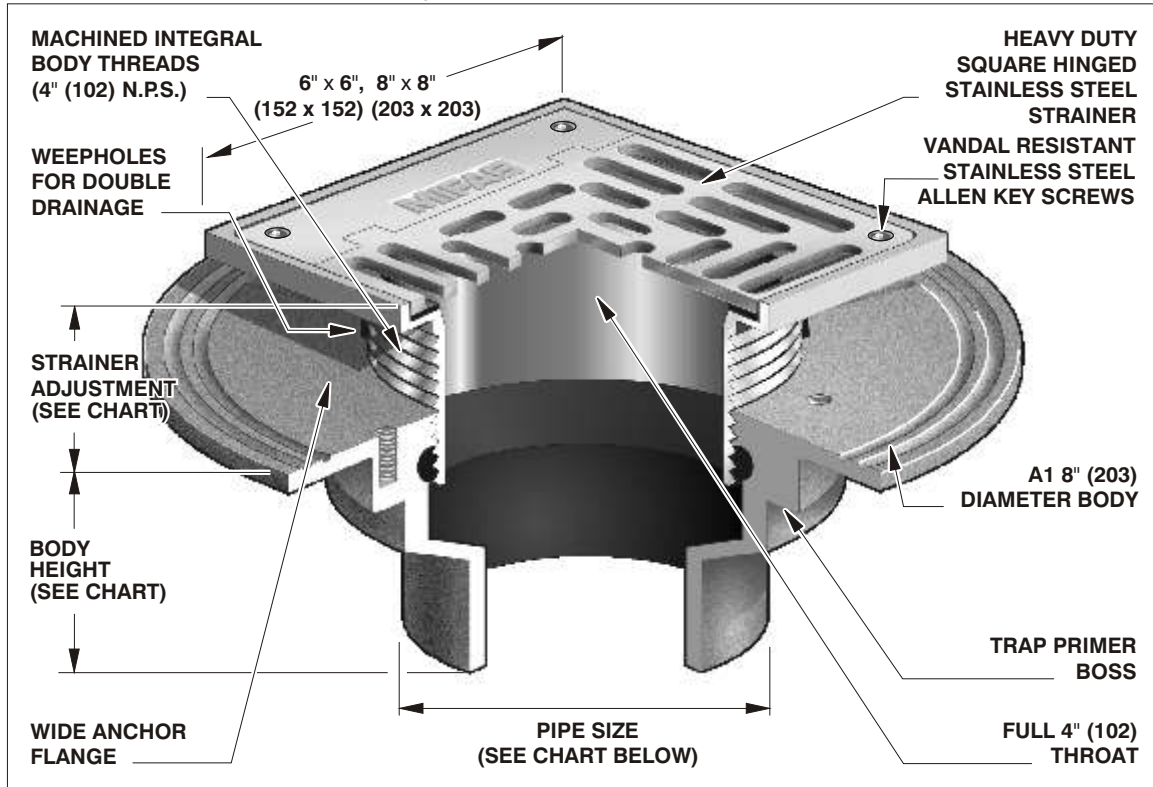

PARTS:



A1 BODY



(*) Denotes STR. Size

F1100-SHG Series meets ANSI/ASME floor drain standard A112.6.3-2001

STRAINER SIZE	STRAINER ADJUSTMENT		ANSI/ASME RATING		PIPE SIZE	BODY HEIGHT				
	MIN	MAX	FREE AREA	LOAD RATING LBS. S.S. (-3)		NO HUB (STANDARD)	PUSH ON (P)	THREADED (T)	INSIDE CAULK (X)	PVC/ABS (-30)/(-31)
6" x 6" (152)	11/16" (17)	1 1/2" (38)	9 in ² (5800 ²)	5000 to 7499	2" (51)	2 3/4" (70)	3 3/8" (86)	2 1/4" (57)	3 3/4" (95)	2 15/16" (75)
8" x 8" (203)	11/16" (17)	2 1/4" (57)	18 in ² (11600 ²)	5000 to 7499	3" (76)	2 3/4" (70)	3 3/8" (86)	2 5/8" (67)	3 3/4" (95)	3 3/4" (95)
					4" (102)	2 3/4" (70)	3 3/8" (86)	2 5/8" (67)	3 3/4" (95)	3 3/4" (95)
					5" (127)	2 3/4" (70)	—	2 5/8" (67)	3 3/4" (95)	—
					6" (152)	3 1/4" (83)	4 3/4" (121)	—	—	—

- OPTIONAL VARIATIONS:**
- | | | | | | | | | |
|--|---------------|----|--|---------------|-----|---|---------------|----|
| <input type="checkbox"/> Stainless steel strainer (standard) | SUFFIX | -3 | <input type="checkbox"/> Stainless steel body (type 316) | SUFFIX | -29 | <input type="checkbox"/> Oval 4" x 9" funnel | SUFFIX | -G |
| <input type="checkbox"/> 3M epoxy finish | -3M | | <input type="checkbox"/> PVC socket connection body | -30 | | <input type="checkbox"/> 6" x 3" x 1" funnel | -J | |
| <input type="checkbox"/> Sediment bucket | -5 | | <input type="checkbox"/> ABS socket connection body | -31 | | <input type="checkbox"/> No hub outlet | (Standard) | |
| <input type="checkbox"/> Security screws (T-20 torx & pin) | -6 | | <input type="checkbox"/> Closure plug | -34 | | <input type="checkbox"/> Push on outlet | P | |
| <input type="checkbox"/> Trap seal primer tapping | -7 | | <input type="checkbox"/> Underdeck clamp | -40 | | <input type="checkbox"/> Threaded outlet | T | |
| <input type="checkbox"/> Backwater valve | -8 | | <input type="checkbox"/> Sump receiver | -41 | | <input type="checkbox"/> Inside caulk outlet | X | |
| <input type="checkbox"/> Acid resistant epoxy coating | -11 | | <input type="checkbox"/> Chrome plated strainer assembly | -49 | | <input type="checkbox"/> Extended wide elastomeric flange | -Z | |
| <input type="checkbox"/> All galvanized | -13 | | <input type="checkbox"/> Threaded side outlet | -90 | | | | |
| <input type="checkbox"/> Extension | -15 | | <input type="checkbox"/> Client logo | -95 | | | | |
| <input type="checkbox"/> Secondary flat strainer | -21 | | <input type="checkbox"/> 4" Round funnel | -F4 | | | | |
| <input type="checkbox"/> Bronze body | -27 | | <input type="checkbox"/> 6" Round funnel | -F6 | | | | |
| <input type="checkbox"/> Stainless steel body (type 304) | -28 | | | | | | | |

Job Name _____	Page No: _____
Section No: _____	Contractor _____
Schedule No: _____	Purchase Order No: _____

MIFAB reserves the right to make changes in material and design without formal notice and obligation.