



# F1100-Z

## FLOOR DRAIN WITH ELASTOMERIC FLANGE FOR NON-MEMBRANE FLOOR AREAS

Internet address: www.mifab.com

Toll Free: 1-800-465-2736

Canada Toll Free: 1-800-387-3880

**SPECIFICATION:** MIFAB Series F1100-Z-1 lacquered cast iron floor drain with anchor flange, weepholes and 1/8" (3) recessed, 13 1/4" (338) diameter elastomeric flange, with standard reinforced 5" (100) diameter, satin finished nickel bronze strainer. (For membrane floors, use MIFAB F1100C-Z Series).

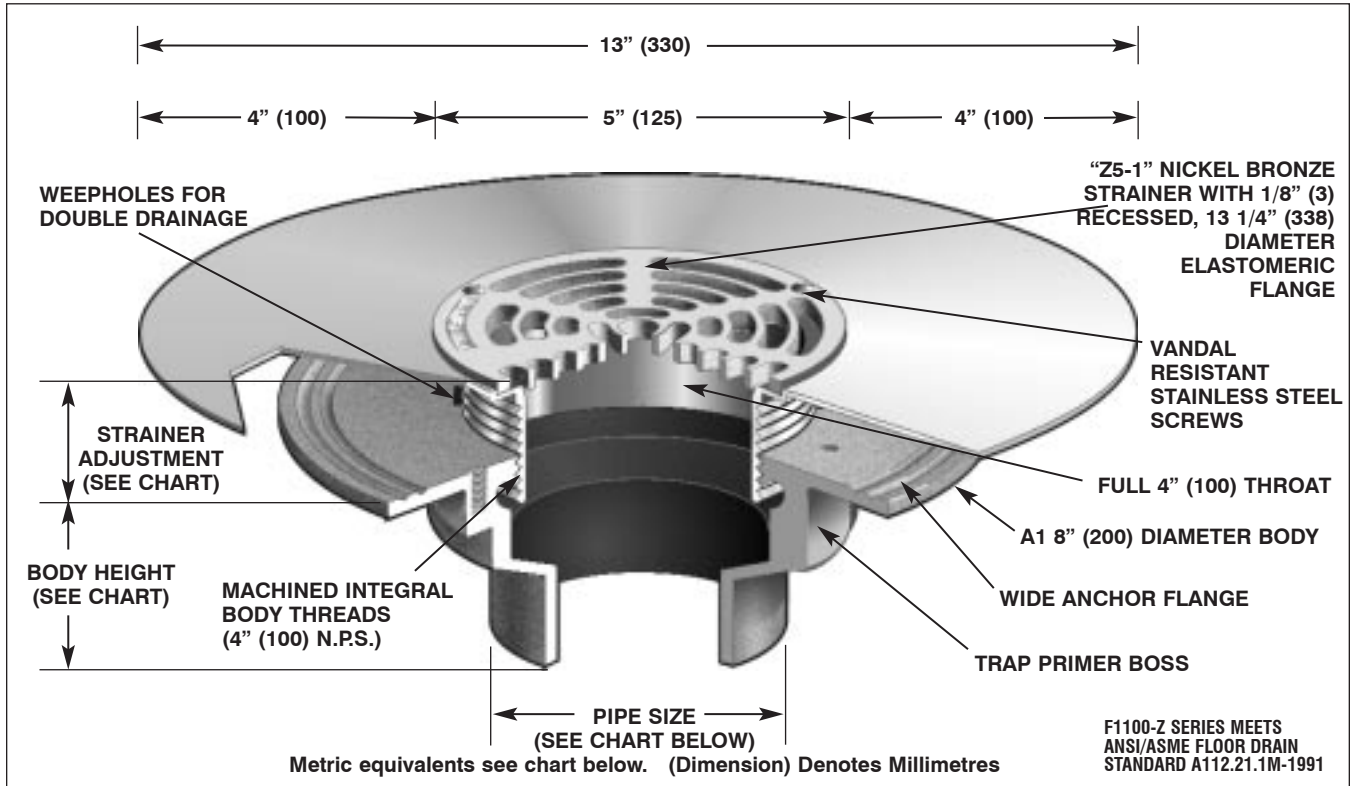

STRAINER DIAMETER	STRAINER ADJUSTMENT		ANSI/ASME RATING		PIPE SIZE	NO HUB	BODY HEIGHT PUSH ON (P)	THREADED (T)	INSIDE CAULK (X)
	MIN	MAX	FREE AREA	LOAD RATING N.B. (-1)					
5" (125)	1/2" (13)	1 1/2" (38)	8 in <sup>2</sup> (5200 <sup>2</sup> )	UP TO 2,000 LBS.	2" (50) 3" (75) 4" (100) 6" (150)	2 3/4" (70) 2 3/4" (70) 2 3/4" (70) 3 1/4" (83)	3 3/8" (86) 3 3/8" (86) 3 3/8" (86) —	2 1/4" (57) 2 5/8" (67) 2 5/8" (67) —	2 3/4" (70) 2 3/4" (70) 2 3/4" (70) —

**OPTIONAL VARIATIONS:**

- Nickel bronze
- Stainless steel strainer**
- 3M epoxy finish
- Sediment bucket
- Vandal proof
- Trap seal primer tapping
- Backwater valve
- Acid resistant epoxy coating
- All galvanized

- suffix -1
- suffix -3**
- suffix -3M
- suffix -5
- suffix -6
- suffix -7
- suffix -8
- suffix -11
- suffix -13

- Extension
- Bronze body
- Stainless steel body (type 304)
- Stainless steel body (type 316)
- PVC socket connection body**
- ABS socket connection body**
- Closure plug
- Deck clamp
- Sump receiver
- Threaded side outlet
- Client logo
- 4" Round funnel
- 6" Round funnel
- Oval 4" x 9" funnel
- 6" x 3" x 1" funnel
- Push on outlet
- Threaded outlet
- Inside caulk outlet

- suffix -15
- suffix -27
- suffix -28
- suffix -29
- suffix -30**
- suffix -31**
- suffix -34
- suffix -40
- suffix -41
- suffix -90
- suffix -95
- suffix -F4
- suffix -F6
- suffix -G
- suffix -J
- suffix P
- suffix T
- suffix X

**PARTS:**

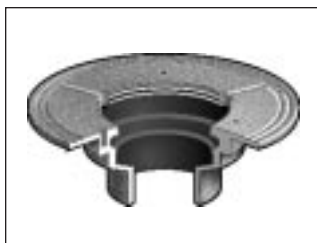

A1 BODY



Z5-1