



F1340-TFB

FLOOR DRAIN WITH 12" ROUND ADJUSTABLE TRACTOR GRATE AND "TRUE-FIT" SEDIMENT BUCKET

Specification: MIFAB® Series F1340-TFB-4 lacquered cast iron deep sump floor drain with anchor flange, weepholes, and adjustable collar with standard 1" (25) thick, 12" (305) round, ductile iron tractor grate and "True-Fit" sediment bucket designed so that grate cannot be set unless the sediment bucket is in position.

Function: Used where waste water contains solids or debris that must be intercepted to prevent drain line clogging. "True-Fit" design ensures that the sediment bucket will always be replaced after cleaning. The grate cannot be set unless the sediment bucket is in place.

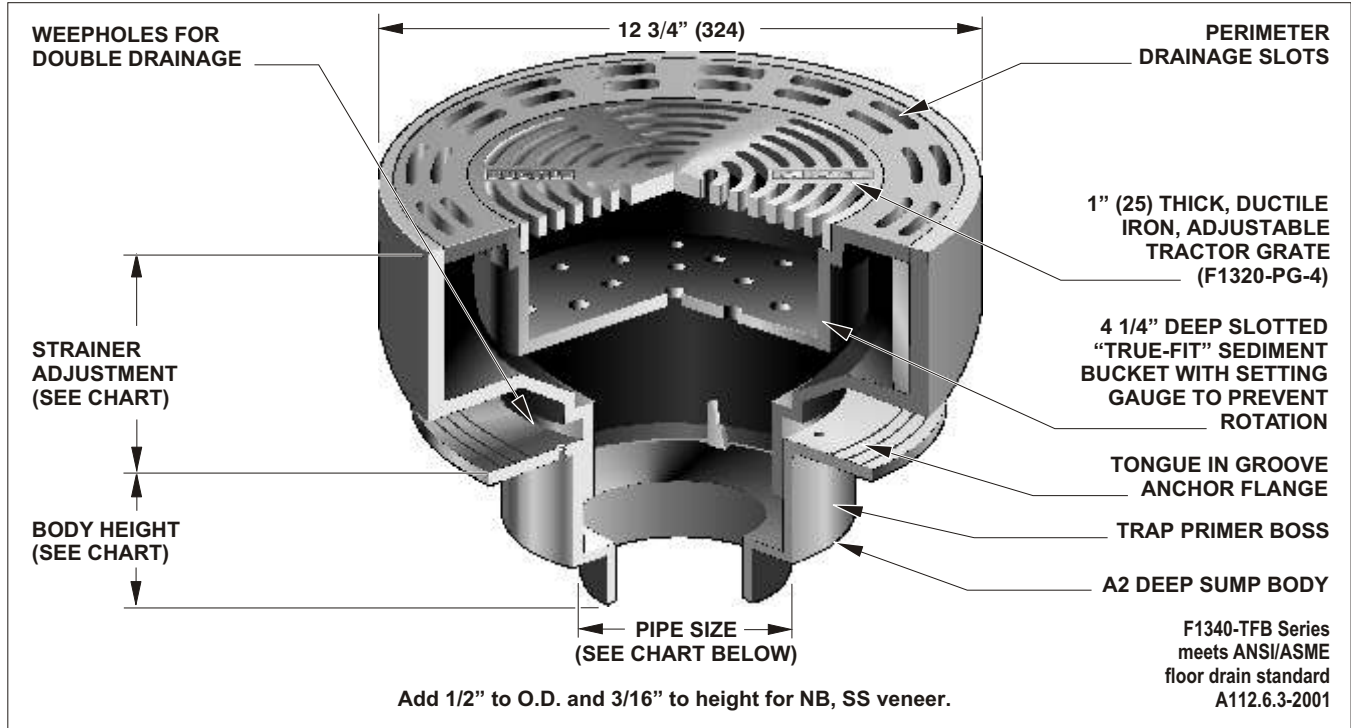

STRAINER DIAMETER	STRAINER ADJUSTMENT MIN MAX		ANSI/ASME RATING		PIPE SIZE	BODY HEIGHT				
			FREE AREA	LOAD RATING		NO HUB (STANDARD)	PUSH ON (P)	THREADED (T)	INSIDE CAULK (X)	PVC/ABS (-30)/(-31)
12 3/4" (324)	2 1/4"	4 1/8"	33 in ² (21290 ²)	ANSI/ASME	2" (51)	5 7/16" (138)	6 1/8" (156)	5 7/16" (138)	6 1/4" (159)	7 1/8" (181)
				LOAD CLASS	3" (76)	5 7/16" (138)	6 1/8" (156)	5 7/16" (138)	6 1/4" (159)	8 1/8" (206)
				"SPECIAL DUTY"	4" (102)	5 7/16" (138)	6 1/8" (156)	5 7/16" (138)	6 1/4" (159)	8 1/8" (206)
				(OVER 10,000 LBS.)	5" (127)	5 7/16" (138)	-	5 7/16" (138)	6 1/4" (159)	-
					6" (152)	5 7/8" (149)	8" (203)	6" (152)	6 1/4" (159)	-
					8" (203)	5 7/8" (149)	-	-	5 5/8" (143)	-

OPTIONAL VARIATIONS:		SUFFIX	SUFFIX		SUFFIX			
<input type="checkbox"/>	Nickel bronze strainer (vener)	-1	<input type="checkbox"/>	Chained grate	-23	<input type="checkbox"/>	Threaded side outlet	- 90
<input type="checkbox"/>	Stainless steel strainer (vener)	-3	<input type="checkbox"/>	Solid secured cover	-24	<input type="checkbox"/>	No hub side outlet	- 90NH
<input type="checkbox"/>	3M epoxy finish	-3M	<input type="checkbox"/>	Bronze body	-27	<input type="checkbox"/>	No hub outlet	(Standard)
<input type="checkbox"/>	Ductile iron grate (standard)	-4	<input type="checkbox"/>	Stainless steel body (type 304)	-28	<input type="checkbox"/>	Membrane clamp	- C
<input type="checkbox"/>	Vandal proof secured grate	-6	<input type="checkbox"/>	Stainless steel body (type 316)	-29	<input type="checkbox"/>	Round 4" funnel	- F4
<input type="checkbox"/>	Trap seal primer tapping	-7	<input type="checkbox"/>	PVC socket connection body	-30	<input type="checkbox"/>	Round 6" funnel	- F6
<input type="checkbox"/>	Backwater valve	-8	<input type="checkbox"/>	ABS socket connection body	-31	<input type="checkbox"/>	Oval 4" x 9" funnel	- G
<input type="checkbox"/>	Acid resistant epoxy coating	-11	<input type="checkbox"/>	2", 3", 4" deep seal trap	-32	<input type="checkbox"/>	6" x 3" x 1" funnel	- J
<input type="checkbox"/>	Galvanized top assembly	-12	<input type="checkbox"/>	Closure plug	-34	<input type="checkbox"/>	Push on outlet	P
<input type="checkbox"/>	All galvanized	-13	<input type="checkbox"/>	S.S. mesh over bucket	-35	<input type="checkbox"/>	Threaded outlet	T
<input type="checkbox"/>	Non tilt grate	-14	<input type="checkbox"/>	Can wash assembly package	-36	<input type="checkbox"/>	Inside caulk outlet	X
<input type="checkbox"/>	Extension	-15	<input type="checkbox"/>	Underdeck clamp	-40	<input type="checkbox"/>	Non adjustable top	- Y
<input type="checkbox"/>	Secondary dome strainer	-20	<input type="checkbox"/>	Sump receiver	-41	<input type="checkbox"/>	Extended wide elastomeric flange	-Z
<input type="checkbox"/>	Secondary flat strainer	-21	<input type="checkbox"/>	Lacquered cast iron funnels	-50			

Job Name: _____	Page No: _____
Section No: _____	Contractor: _____
Schedule No: _____	Purchase Order No: _____

MIFAB reserves the right to make changes in material and design without formal notice and obligation.