



F1230

FLOOR DRAIN FOR NON-MEMBRANE FLOOR AREAS

Internet address: www.mifab.com

Toll Free: 1-800-465-2736

Canada Toll Free: 1-800-387-3880

SPECIFICATION: MIFAB Series F1230 lacquered cast iron floor drain and standard 1/2" (13) thick, reinforced, 5" (125) diameter ductile iron grate.

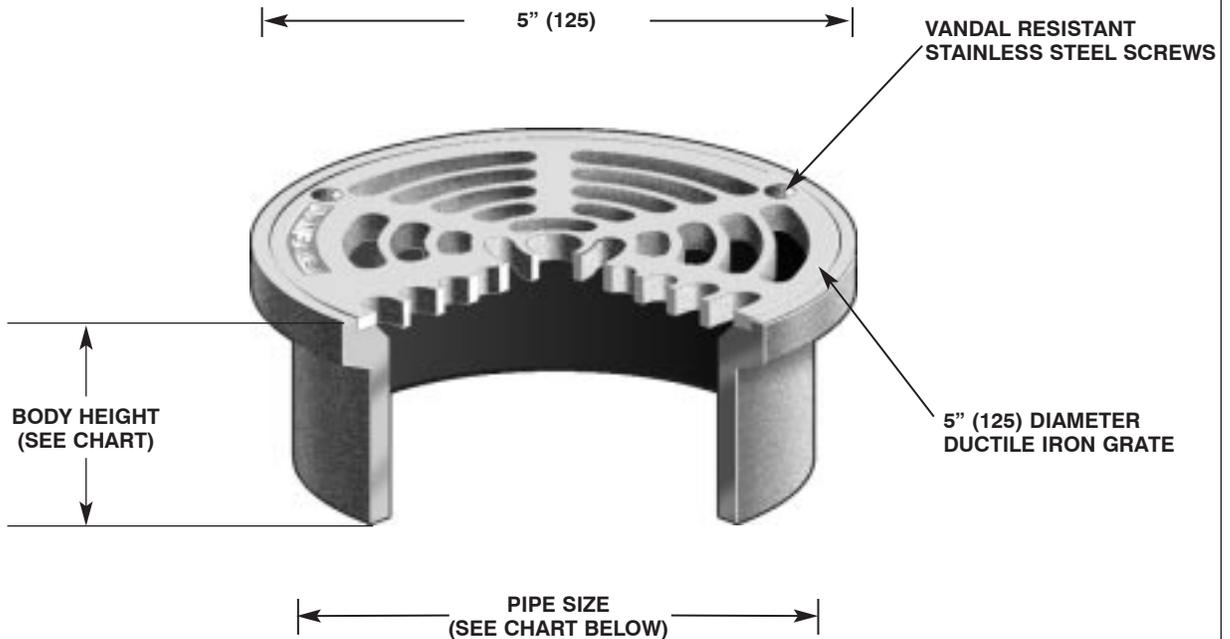

F1230 SERIES MEETS
ANSI/ASME FLOOR DRAIN
STANDARD A112.21.1M-1991

STRAINER DIAMETER	ANSI/ASME RATING		PIPE SIZE	BODY HEIGHT				
	FREE AREA	LOAD RATING N.B. (-1) D.I. (-4)		CAST IRON BODY (NH)	NICKEL BRONZE BODY (-1)	PVC BODY (-30)	ABS BODY (-31)	
5" (125)	8 in ² (5200 ²)	UP TO 2,000 LBS.	UP TO 7,499 LBS.	2" (50)	2 3/16" (56)	2 3/16" (56)	2 5/8" (67)	2 5/8" (67)
				3" (75)	2 3/16" (56)	2 3/16" (56)	2 5/8" (67)	2 5/8" (67)
				4" (100)	2 3/16" (56)	2 3/16" (56)	2 5/8" (67)	2 5/8" (67)

OPTIONAL VARIATIONS:

- Nickel bronze (grate and body)
- 3M epoxy finish
- Ductile iron grate (standard)
- Sediment bucket
- Vandal proof
- Backwater valve
- Acid resistant epoxy coating

- suffix -1
- suffix -3M
- suffix -4
- suffix -5
- suffix -6
- suffix -8
- suffix -11

- PVC socket connection body
- ABS socket connection body
- Lacquered cast iron funnels
- Client logo
- Round 4" funnel
- Round 6" funnel
- Oval 4" x 9" funnel
- 6" x 3" x 1" funnel

- suffix -30
- suffix -31
- suffix -50
- suffix -95
- suffix -F4
- suffix -F6
- suffix -G
- suffix -J