



F1570

24" x 24" HEAVY DUTY PARKING AREA CATCH BASIN

Internet address: www.mifab.com

Toll Free: 1-800-465-2736

Canada Toll Free: 1-800-387-3880

SPECIFICATION: MIFAB Series F1570-(A,B,C,D or E) powder epoxy coated heavy duty parking area catch basin with anchor flange, and extra heavy duty 24" (610) x 24" (610) two section cast iron grates with a free area of 200 square inches (129,032²). Grates to have maximum 13/16" (21) openings.

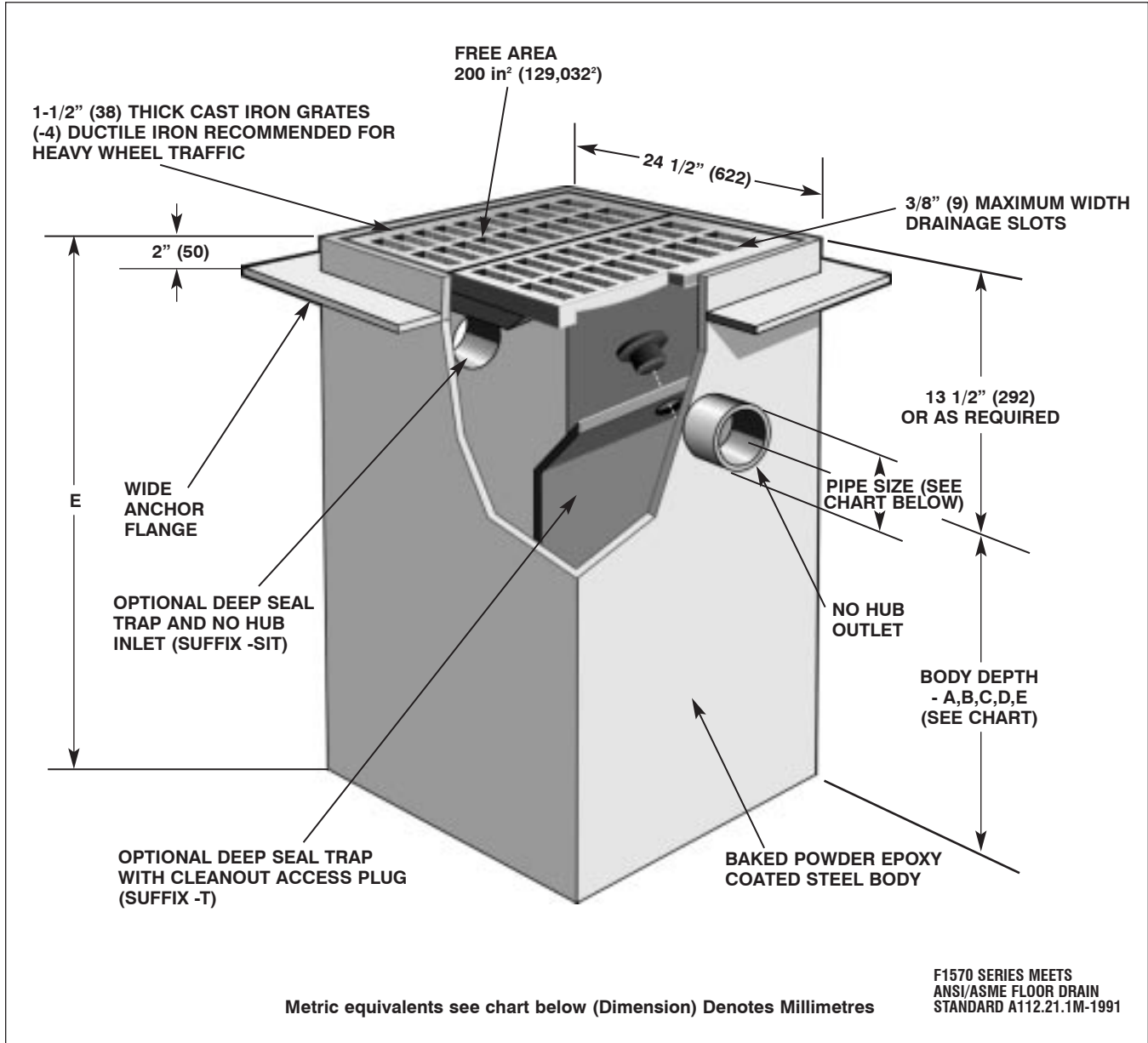

MODEL NO.	NO HUB PIPE SIZE	BODY DEPTH				
		(A)	(B)	(C)	(D)	(E)
F1570-(A, B, C, D OR E)	2", 3", 4", 6" (50,75,100,150)	18" (457)	24" (610)	30" (762)	36" (914)	SPECIAL

OPTIONAL VARIATIONS:

- Stainless steel veneer top assembly
- 3M epoxy finish
- Ductile iron grate
- Vandal proof
- Galvanized grate
- All galvanized
- Extension

- suffix -3
- suffix -3M
- suffix -4
- suffix -6
- suffix -12
- suffix -13
- suffix -15

- Stainless steel body (type 304)
- Stainless steel body (type 316)
- Client logo
- Membrane clamp
- Side inlet
- Side inlet trap
- Deep seal trap on outlet
- Special outlet size

- suffix -28
- suffix -29
- suffix -95
- suffix C
- suffix -SI
- suffix -SIT
- suffix -T
- specify