



**F1660**

**LARGE CAPACITY FLUSHING RIM FLOOR DRAIN**

**Specification:** MIFAB® F1660, 25" square large capacity flushing rim floor drain with white acid resistant epoxy coated cast iron interior and exterior body, 24" (610) diameter nickel bronze grate and 1" flushing connection in body.

**Function:** Used in animal dens and laboratories. The large grate openings allow solids and animal wastes to pass into the drain. The acid resistant epoxy coating and flushing connection provide for a sanitary condition.

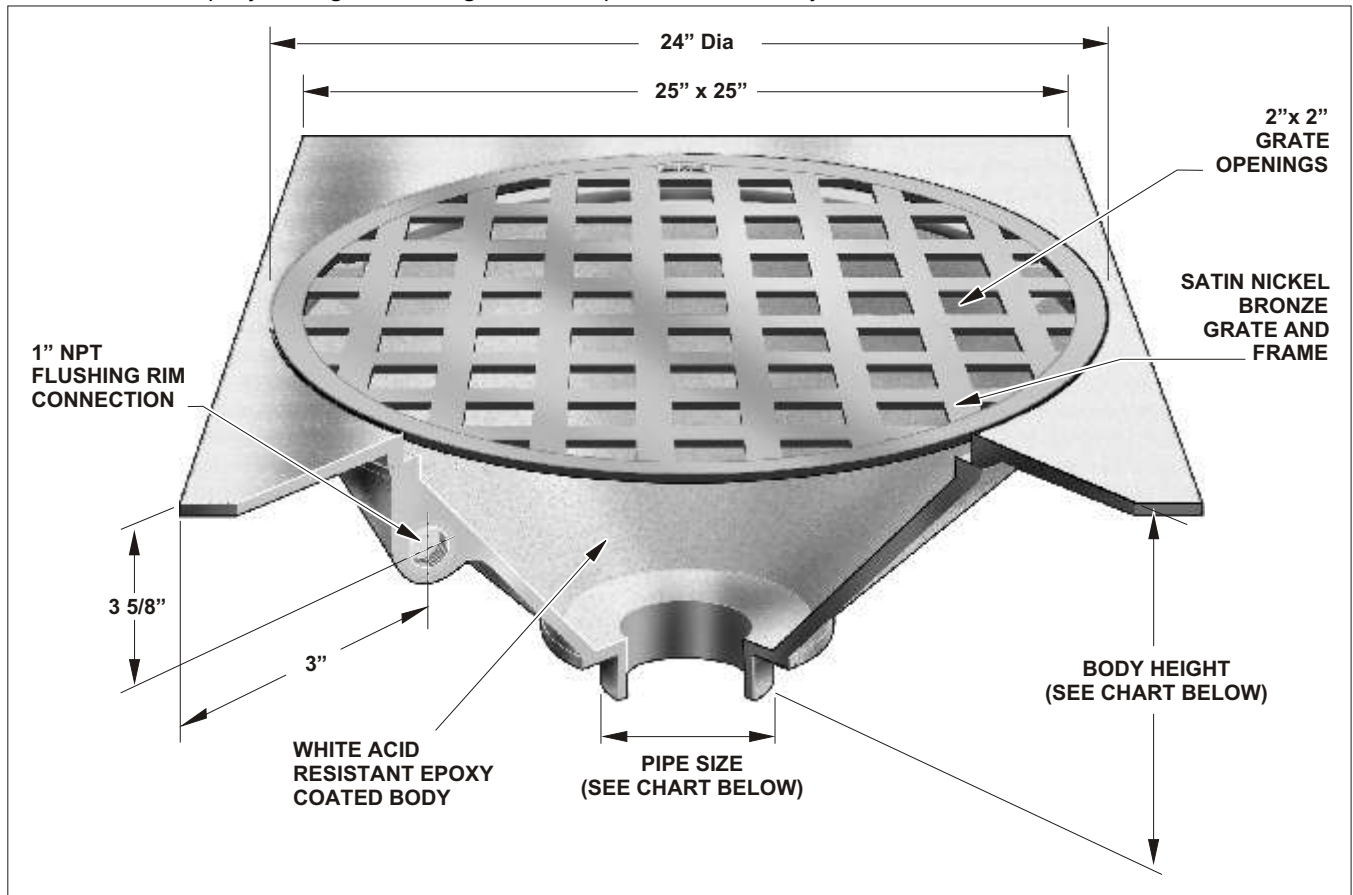

\* See F1670 for water supply control box to be used with the flushing rim floor drain.

\* Use vacuum breaker between the potable water supply and the connection to the flushing rim connection. (By others)

STRAINER DIAMETER	ANSI/ASME RATING		PIPE SIZE	BODY HEIGHT				
	FREE AREA	LOAD RATING N.B.(-1)		NO HUB (STANDARD)	PUSH ON (P)	THREADED (T)	INSIDE CAULK (X)	PVC/ABS (-30)/(-31)
24" (610)	232 in <sup>2</sup>	UP TO 2,000 LBS	2" (51)	12 1/2" (318)	13 1/8" (333)	12 (305)	13 1/2" (343)	12 11/16" (322)
			3" (76)	12 1/2" (318)	13 1/8" (333)	12 3/8" (343)	13 1/2" (343)	13 1/2" (343)
			4" (102)	12 1/2" (318)	13 1/8" (333)	12 3/8" (343)	13 1/2" (343)	13 1/2" (343)
			5" (127)	12 1/2" (318)	-	12 3/8" (343)	13 1/2" (343)	-
			6" (152)	13" (330)	14 1/2" (368)	-	-	-

**OPTIONAL VARIATIONS:**

- Nickel bronze grate (standard)
- Sediment bucket
- Vandal proof fixed grate
- Trap seal primer tapping
- Backwater valve
- All galvanized
- Secondary flat strainer
- PVC socket connection body
- ABS socket connection body

**SUFFIX**

- 1  Threaded side outlet
- 5  No hub side outlet
- 6  No hub outlet
- 7  Trap with flushing connection
- 8  Push on outlet
- 13  Threaded outlet
- 21  Inside caulk outlet
- 30  Extended wide elastomeric flange
- 31

**SUFFIX**

- 90
- 90NH
- (Standard)
- G
- P
- T
- X
- Z

Job Name _____	Page No: _____
Section No: _____	Contractor _____
Schedule No: _____	Purchase Order No: _____