

Specification: MIFAB® F1530-4 lacquered cast iron floor drain with anchor flange, weepholes, 16" (406) diameter fixed, heavy duty membrane collar with weepholes and standard 1" (25) thick, 9" (229) round, ductile iron tractor grate.

Function: Used in parking structures where wide, heavy duty membrane collar is required to anchor drain in slab.

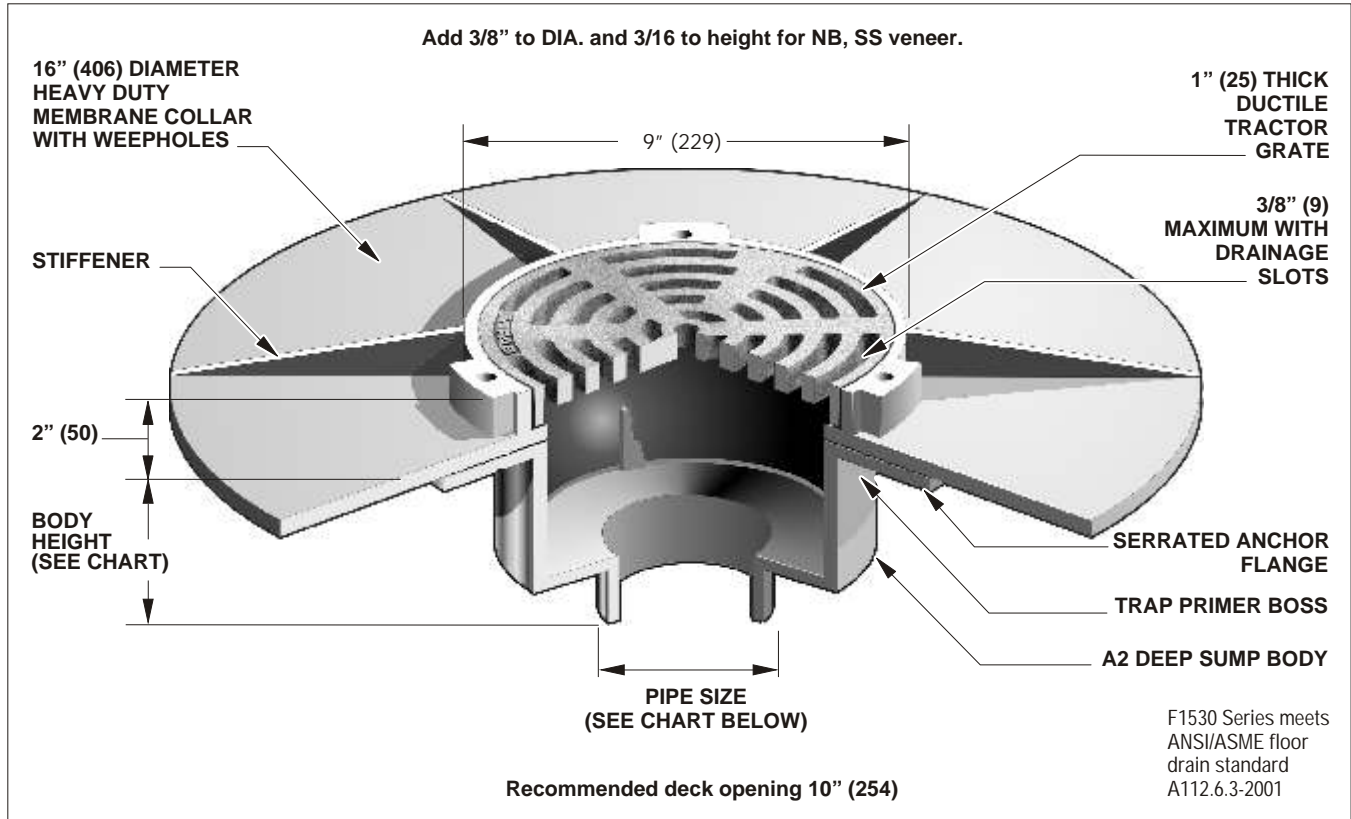

STRAINER DIAMETER	ANSI/ASME RATING		PIPE SIZE	BODY HEIGHT				
	FREE AREA	LOAD RATING N.B.(-1), S.S. (-3), D.I.(-4)		NO HUB (STANDARD)	PUSH ON (P)	THREADED (T)	INSIDE CAULK (X)	PVC/ABS (-30)/(-31)
9" (229)	18 in <sup>2</sup> (11,613 <sup>2</sup> )	ANSI/ASME LOAD CLASS "SPECIAL DUTY" (OVER 10,000 LBS.)	2" (51)	5 7/16" (138)	6 1/8" (156)	5 7/16" (138)	6 1/4" (159)	7 1/8" (181)
			3" (76)	5 7/16" (138)	6 1/8" (156)	5 7/16" (138)	6 1/4" (159)	8 1/8" (206)
			4" (102)	5 7/16" (138)	6 1/8" (156)	5 7/16" (138)	6 1/4" (159)	8 1/8" (206)
			5" (127)	5 7/16" (138)	-	5 7/16" (138)	6 1/4" (159)	-
			6" (152)	5 7/8" (149)	8" (203)	6" (152)	6 1/4" (159)	-
			8" (203)	5 7/8" (149)	-	-	5 5/8" (143)	-

**OPTIONAL VARIATIONS:**

- Nickel bronze (vener)
- Stainless steel (vener)
- 3M epoxy finish
- Ductile iron grate (standard)
- Sediment bucket
- Vandal proof
- Trap seal primer tapping
- Backwater valve
- Acid resistant epoxy coating
- Galvanized top assembly
- All galvanized
- Secondary dome strainer
- Secondary flat strainer
- Bronze body

**SUFFIX**

- 1  Stainless steel body (type 304)
- 3  Stainless steel body (type 316)
- 3M  PVC socket connection body
- 4  ABS socket connection body
- 5  Closure plug
- 6  S.S. mesh over bucket
- 7  Underdeck clamp
- 8  Sump receiver
- 11  Threaded side outlet
- 12  No hub side outlet
- 13  No hub outlet
- 20  Push on outlet
- 21  Threaded outlet
- 27  Inside caulk outlet

**SUFFIX**

- 28
- 29
- 30
- 31
- 34
- 35
- 40
- 41
- 90
- 90NH (standard)
- P
- T
- X

Job Name _____	Page No: _____
Section No: _____	Contractor _____
Schedule No: _____	Purchase Order No: _____