



F1490

FLOOR DRAIN WITH 15" SQUARE HEAVY DUTY TRACTOR GRATE AND DEEP SUMP

Internet address: www.mifab.com

Toll Free: 1-800-465-2736

Canada Toll Free: 1-800-387-3880

SPECIFICATION: MIFAB Series F1490-4 epoxy coated large capacity floor drain with deep sump body, and standard 1" (25) thick, 15" (380) square ductile iron tractor grate with a free area of 81 square inches (52,259²).

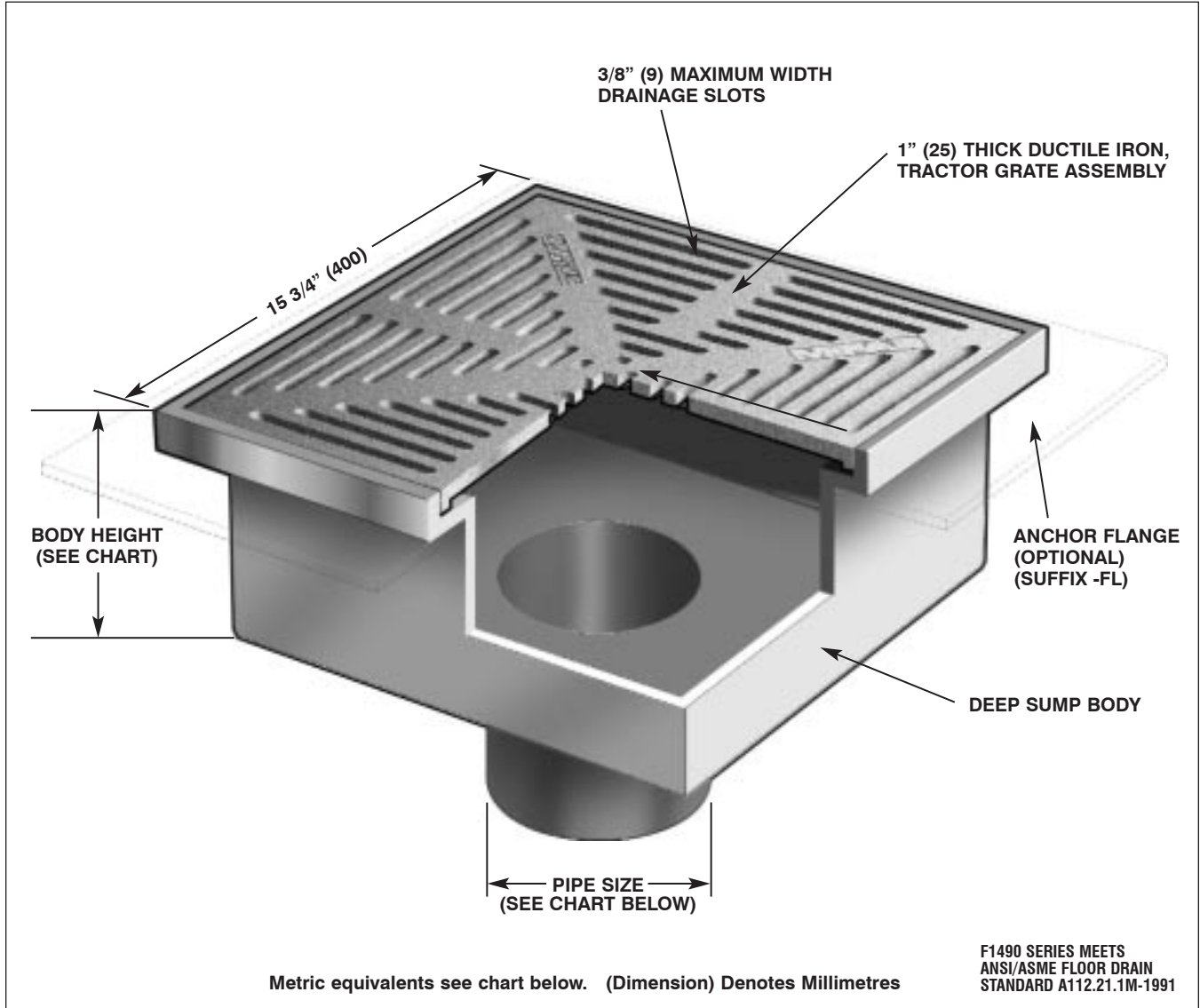

STRAINER SIZE	ANSI/ASME RATING		PIPE SIZE	NO HUB	BODY HEIGHT PUSH ON (P)	THREADED (T)	INSIDE CAULK (X)
	FREE AREA	LOAD RATING					
15" x 15" (380 x 380)	80 in ² (51,613 ²)	ANSI/ASME	2" (50)	8 1/2" (213)	9 1/4" (231)	8" (200)	8 1/2" (213)
		LOAD CLASS	3" (75)	8 1/2" (213)	9 1/4" (231)	8" (200)	8 1/2" (213)
		"SPECIAL DUTY"	4" (100)	8 1/2" (213)	9 1/4" (231)	8" (200)	8 1/2" (213)
		(OVER 10,000 LBS.)	6" (150)	8 1/2" (213)	9 1/4" (231)	8" (200)	8 1/2" (213)

OPTIONAL VARIATIONS:

- Stainless steel veneer
- 3M epoxy finish
- Ductile iron grate (standard)
- Sediment bucket
- Vandal proof
- Trap seal primer tapping
- Backwater valve
- Acid resistant epoxy coating
- All galvanized

- suffix -3
- suffix -3M
- suffix -4
- suffix -5
- suffix -6
- suffix -7
- suffix -8
- suffix -11
- suffix -13

- Secondary dome
- Secondary strainer
- Less grate
- Stainless steel body and grate (type 304)
- Stainless steel body and grate (type 316)
- Membrane clamp
- Anchor flange
- Push on outlet
- Threaded outlet
- Inside caulk outlet

- suffix -20
- suffix -21
- suffix -22
- suffix -28
- suffix -29
- suffix C
- suffix -FL
- suffix P
- suffix T
- suffix X