



# F1170C

## INTERNATIONAL FLOOR DRAIN WITH INTEGRAL TRAP FOR MEMBRANE FLOOR AREAS

Internet address: [www.mifab.com](http://www.mifab.com)

Toll Free: 1-800-465-2736

Canada Toll Free: 1-800-387-3880

**SPECIFICATION:** MIFAB Series F1170C-(-)-1 lacquered cast iron floor drain with integral trap, 2" (50) cleanout (rodding eye), anchor flange, cast iron membrane clamp ring with primary and secondary weepholes for waterproofing membrane, and standard reinforced, (specify diameter), satin finished nickel bronze strainer. (Specify -44-2" (50) no hub or -44-T-1 1/2" (38) female threaded back inlets as shown and required. Maximum three @ 90 degrees. Specify location - A,B, or C).

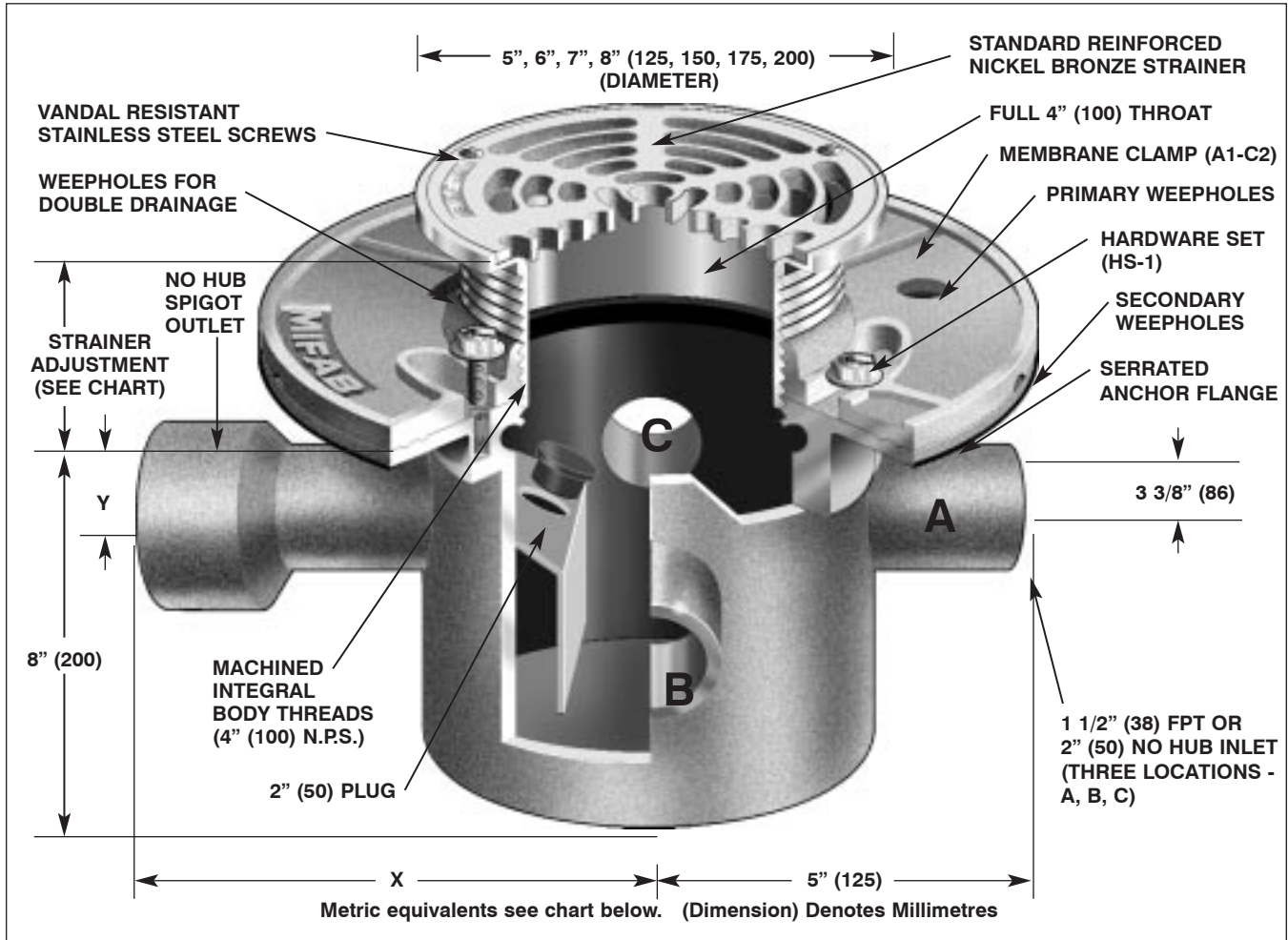

STRAINER DIAMETER	STRAINER ADJUSTMENT		ANSI/ASME RATING		NO HUB SPIGOT OUTLET SIZE	BODY DIMENSIONS	
	MIN	MAX	FREE AREA	LOAD RATING N.B.(-1) D.I. (-4)		Y	X
5" (125)	1 9/16" (40)	2 11/16" (68)	8 in <sup>2</sup> (5200 <sup>2</sup> )	UP TO 2,000 LBS. UP TO 7,499 LBS.	2" (50)	5 3/4" (146)	8 1/2" (210)
6" (150)	1 11/16" (43)	2 5/8" (67)	9 in <sup>2</sup> (5800 <sup>2</sup> )	UP TO 2,000 LBS. —	3" (75)	5 3/8" (136)	7 1/4" (184)
7" (175)	1 1/2" (38)	2 5/8" (67)	12 in <sup>2</sup> (7700 <sup>2</sup> )	UP TO 2,000 LBS. —	4" (100)	5" (125)	6" (150)
8" (200)	1 7/8" (48)	2 3/4" (70)	18 in <sup>2</sup> (11600 <sup>2</sup> )	UP TO 2,000 LBS. OVER 10000 LBS.			

**OPTIONAL VARIATIONS:**

- Nickel bronze (standard)
- Stainless steel strainer**
- 3M epoxy finish
- Ductile iron grate (5", 8" only)
- Vandal proof
- Trap seal primer tapping
- Acid resistant epoxy coating
- All galvanized
- Extension
- 2" (50) no hub inlet (specify A,B,C locations)
- suffix -1
- suffix -3
- suffix -3M
- suffix -4
- suffix -6
- suffix -7
- suffix -11
- suffix -13
- suffix -15
- suffix -44-2"
- 1 1/2" (38) female threaded inlet (specify A,B,C locations)
- Lacquered cast iron funnels
- Client logo
- Clamp ring for low rough-in (min. 1/2" (13))
- 4" Round funnel
- 6" Round funnel
- Oval 4" x 9" funnel
- 6" x 3" x 1" funnel
- Vertical outlet
- Elastomeric flange
- suffix -44T-1 1/2"
- suffix -50
- suffix -95
- suffix C1
- suffix -F4
- suffix -F6
- suffix -G
- suffix -J
- suffix -V
- suffix -Z