



F1130C

FLOOR DRAIN WITH INTEGRAL DEEP SEAL TRAP AND CLEANOUT

Internet address: www.mifab.com

Toll Free: 1-800-465-2736

Canada Toll Free: 1-800-387-3880

SPECIFICATION: MIFAB Series F1130C-()-1 lacquered cast iron floor drain with anchor flange, cast iron membrane clamp ring with primary and secondary weepholes for waterproofing membrane, seepage collection sump, integral deep seal trap and standard reinforced (specify diameter), satin finished nickel bronze strainer and standard reinforced 5" (125) diameter satin finished nickel bronze top assembly floor cleanout with access cover, "O" ring Test Seal and plug with primary gasket seal.

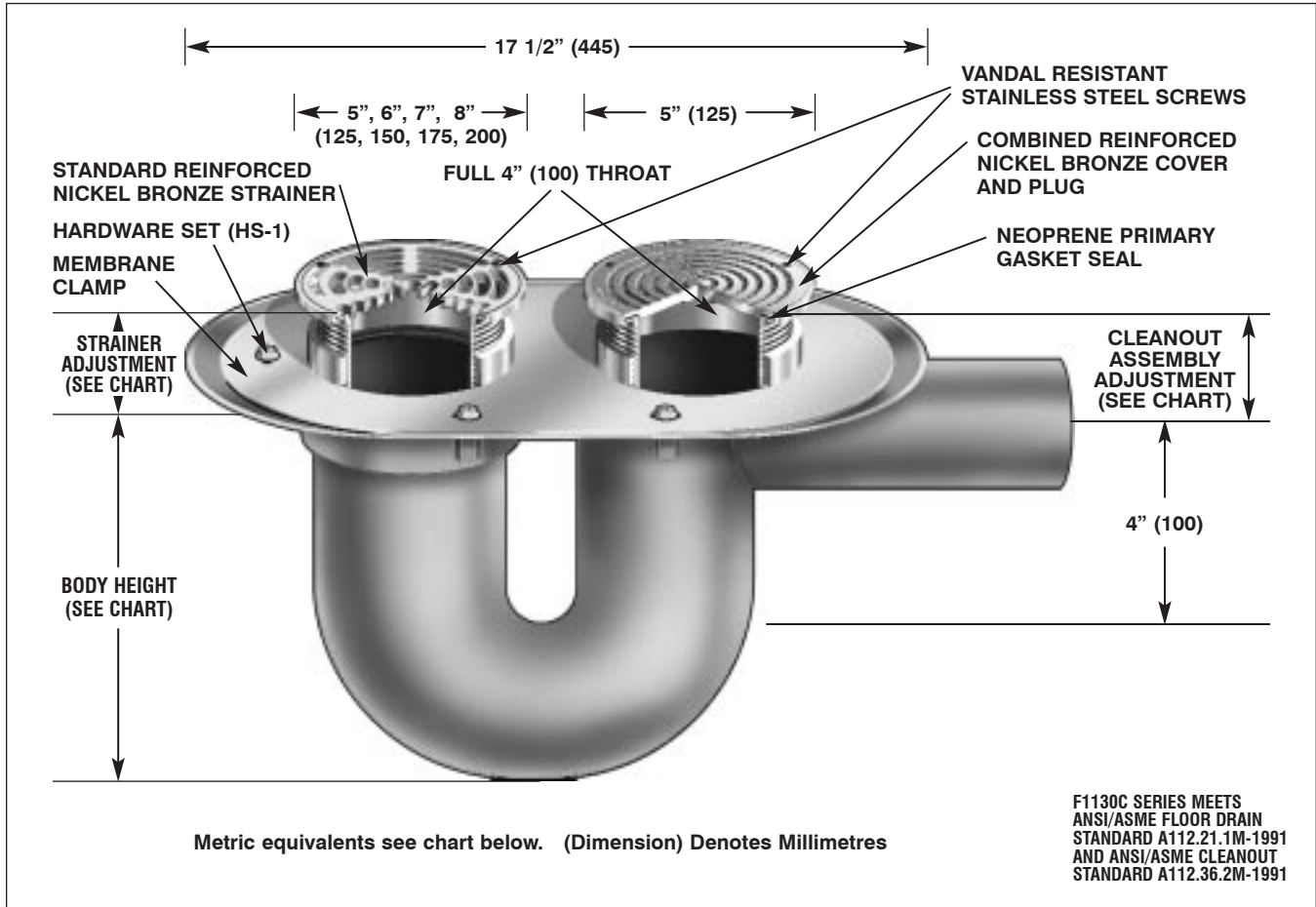

Metric equivalents see chart below. (Dimension) Denotes Millimetres

STRAINER DIAMETER	STRAINER ADJUSTMENT		ANSI/ASME RATING		CLEANOUT ASSEMBLY SIZE	CLEANOUT ASSEMBLY ADJUSTMENT		LOAD RATING		BODY HEIGHT	
	MIN	MAX	FREE AREA	LOAD RATING N.B.(-1) D.I. (-4)		MIN.	MAX.	N.B.(-1) D.I. (-4)	PIPE SIZE	NO HUB	
5" (125)	1 5/8" (41)	2 5/8" (67)	8 in ² (5200 ²)	UP TO 2,000 LBS. UP TO 7,499 LBS.	5" (125)	1 5/8" (41)	2 5/8" (67)	UP TO 4,999 LBS. UP TO 7,499 LBS.	2" (50)	13 1/2" (345)	
6" (150)	1 5/8" (41)	2 5/8" (67)	9 in ² (5800 ²)	UP TO 2,000 LBS. —					3" (75)	13 1/2" (345)	
7" (175)	1 5/8" (41)	2 5/8" (67)	12 in ² (7700 ²)	UP TO 2,000 LBS. —					4" (100)	13 1/2" (345)	
8" (200)	1 7/8" (48)	2 5/8" (67)	18 in ² (11600 ²)	UP TO 2,000 LBS. OVER 10,000 LBS.							

OPTIONAL VARIATIONS:

- Nickel bronze (standard) suffix -1
- Stainless steel strainer and cover** suffix -3
- 3M epoxy finish suffix -3M
- Ductile iron suffix -4
- (5", 8" grates only, 5" cleanout top only) suffix -5
- Sediment bucket suffix -6
- Vandal proof suffix -6
- Trap seal primer tapping suffix -7
- Backwater valve suffix -8
- Acid resistant epoxy coating suffix -11
- All galvanized suffix -13
- Extension suffix -15
- Square top suffix -16
- ABS plug with neoprene gasket (cleanout only) suffix -34
- Lacquered cast iron funnels suffix -50
- Client logo suffix -95
- 4" Round funnel suffix -F4
- 6" Round funnel suffix -F6
- Oval 4" x 9" funnel suffix -G
- 6" x 3" x 1" funnel suffix -J
- Elastomeric flange suffix -Z