



F1100-K

FLOOR DRAIN WITH DOME STRAINER FOR NON-MEMBRANE FLOOR AREAS

Internet address: www.mifab.com

Toll Free: 1-800-465-2736

Canada Toll Free: 1-800-387-3880

SPECIFICATION: MIFAB Series F1100-K-1 lacquered cast iron floor drain with anchor flange, weepholes, and "K" dome satin finished nickel bronze strainer. (For membrane floors, use MIFAB F1100C-K Series.)

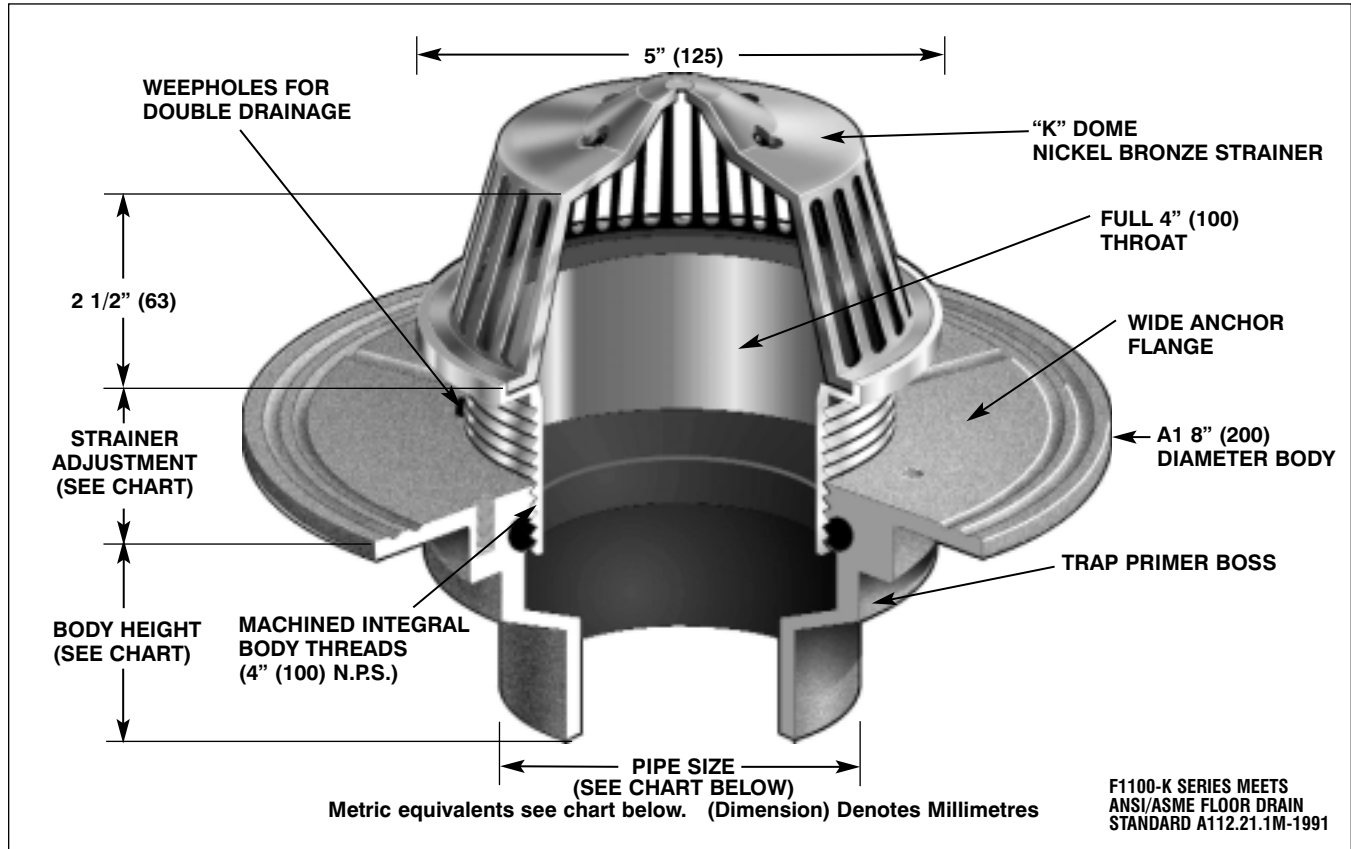

STRAINER DIAMETER	STRAINER ADJUSTMENT		ANSI/ASME RATING	PIPE SIZE	NO HUB	BODY HEIGHT		INSIDE CAULK (X)
	MIN	MAX	FREE AREA			PUSH ON (P)	THREADED (T)	
5" (125)	1/2" (13)	1 1/2" (38)	15 in ² (9,677 ²)	2" (50)	2 3/4" (70)	3 3/8" (86)	2 1/4" (57)	2 3/4" (70)
				3" (75)	2 3/4" (70)	3 3/8" (86)	2 5/8" (67)	2 3/4" (70)
				4" (100)	2 3/4" (70)	3 3/8" (86)	2 5/8" (67)	2 3/4" (70)
				6" (150)	3 1/4" (83)	—	—	—

OPTIONAL VARIATIONS:

- Nickel bronze (standard)
- Stainless steel strainer**
- 3M epoxy finish
- Sediment bucket
- Vandal proof
- Trap seal primer tapping
- Backwater valve
- Acid resistant epoxy coating
- All galvanized

- suffix -1
- suffix -3
- suffix -3M
- suffix -5
- suffix -6
- suffix -7
- suffix -8
- suffix -11
- suffix -13

- Extension
- Bronze body
- Stainless steel body (type 304)
- Stainless steel body (type 316)
- PVC socket connection body**
- ABS socket connection body**
- Closure plug
- Deck clamp
- Sump receiver
- Lacquered cast iron dome
- Threaded side outlet
- Push on outlet
- Threaded outlet
- Inside caulk outlet
- Elastomeric flange

- suffix -15
- suffix -27
- suffix -28
- suffix -29
- suffix -30
- suffix -31
- suffix -34
- suffix -40
- suffix -41
- suffix -50
- suffix -90
- suffix P
- suffix T
- suffix X
- suffix -Z

PARTS:



A1 BODY



K-1