



# F1450

## FLOOR DRAIN WITH 12" SQUARE ADJUSTABLE TRACTOR GRATE AND EXTRA DEEP SUMP

Internet address: www.mifab.com

Toll Free: 1-800-465-2736

Canada Toll Free: 1-800-387-3880

**SPECIFICATION:** MIFAB Series F1450-4 lacquered cast iron floor drain with anchor flange, weepholes, and adjustable collar with extra deep sump body and standard 1" (25) thick, 12" (300) hinged square ductile iron tractor grate.

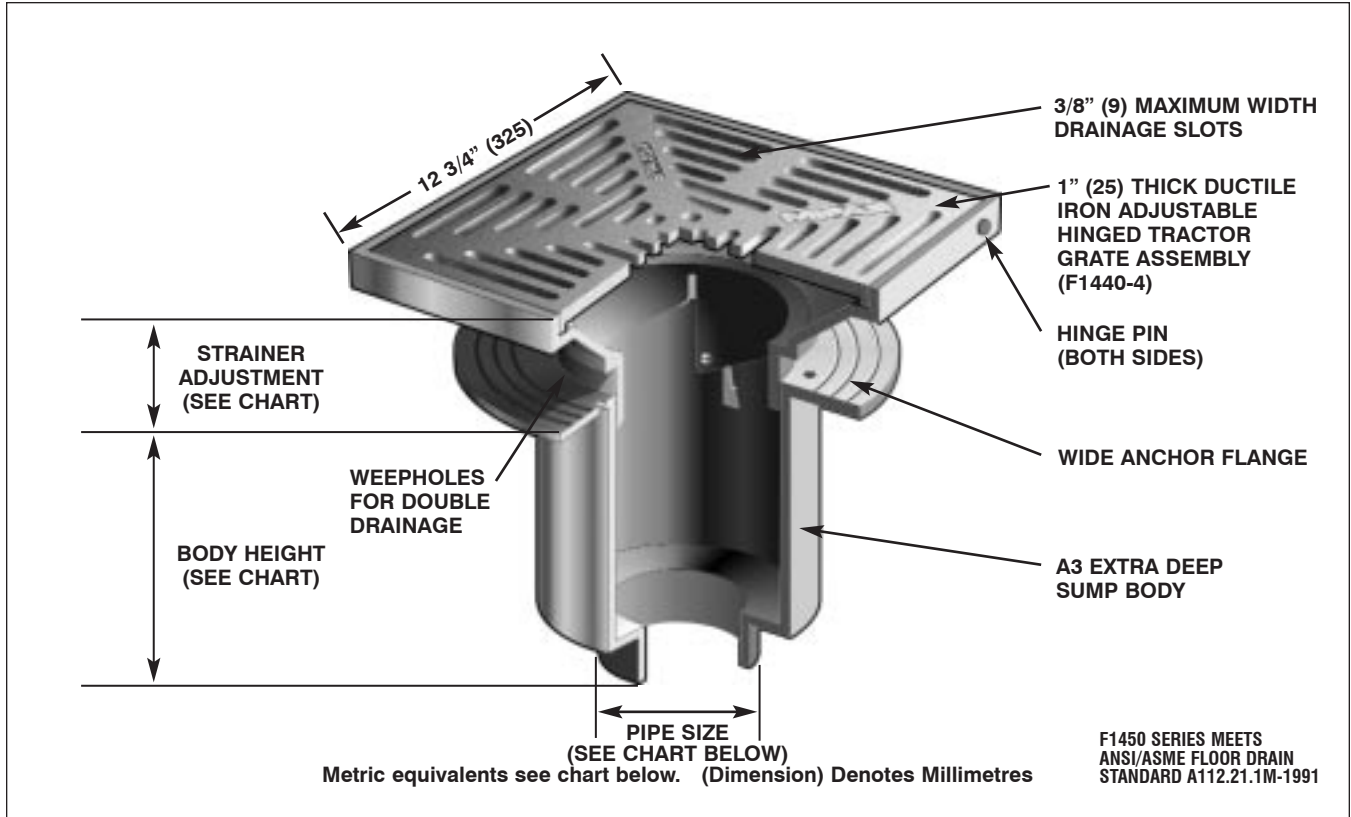

STRAINER SIZE	STRAINER ADJUSTMENT		ANSI/ASME RATING		PIPE SIZE	NO HUB	BODY HEIGHT		INSIDE CAULK (X)	
	MIN	MAX	FREE AREA	LOAD RATING			PUSH ON (P)	THREADED (T)		
12" x 12" (300 x 300)	2 1/4" (57)	4 1/8" (105)	51 in <sup>2</sup> (32,903 <sup>2</sup> )	ANSI/ASME	2" (50)	12" (300)	12 3/4" (325)	11 1/2" (292)	12" (300)	
				LOAD CLASS			3" (75)	12 3/4" (325)		11 7/8" (300)
				"SPECIAL DUTY"			4" (100)	12 3/4" (325)		11 7/8" (300)
				(OVER 10,000 LBS.)			6" (150)	12" (300)		—

**OPTIONAL VARIATIONS:**

- Nickel bronze (vener)
- Stainless steel (vener)**
- 3M epoxy finish
- Ductile iron grate (standard)
- Sediment bucket
- Vandal proof
- Trap seal primer tapping
- Backwater valve
- Acid resistant epoxy coating
- Galvanized grate and frame

- suffix -1
- suffix -3**
- suffix -3M
- suffix -4
- suffix -5
- suffix -6
- suffix -7
- suffix -8
- suffix -11
- suffix -12

- All galvanized
- Extension
- Secondary dome
- Secondary strainer
- Hinged locking grate
- PVC socket connection body outlet**
- ABS socket connection body outlet**
- Closure plug
- Bronze mesh bucket
- Deck clamp
- Sump receiver
- Lacquered cast iron funnels
- Threaded side outlet
- Client logo
- Membrane clamp
- Round 4" funnel
- Round 6" funnel
- Oval 4" x 9" funnel
- 6" x 3" x 1" funnel
- Push on outlet
- Threaded outlet
- Inside caulk outlet
- Non adjustable top
- Elastomeric flange

- suffix -13
- suffix -15
- suffix -20
- suffix -21
- suffix -26
- suffix -30**
- suffix -31**
- suffix -34
- suffix -35
- suffix -40
- suffix -41
- suffix -50
- suffix -90
- suffix -95
- suffix C
- suffix -F4
- suffix -F6
- suffix -G
- suffix -J
- suffix P
- suffix T
- suffix X
- suffix -Y
- suffix -Z

**PARTS:**



A3 BODY



F1440-4