



# F1100C-Z

## FLOOR DRAIN WITH ELASTOMERIC FLANGE FOR MEMBRANE FLOOR AREAS

Internet address: [www.mifab.com](http://www.mifab.com)

Toll Free: 1-800-465-2736

Canada Toll Free: 1-800-387-3880

**SPECIFICATION:** MIFAB Series F1100C-Z-1 lacquered cast iron floor drain with anchor flange and 1/8" (3) recessed, 13 1/4" (338) diameter elastomeric flange, cast iron membrane clamp ring with primary and secondary weepholes for waterproofing membrane, and standard reinforced 5" (125) diameter, satin finished nickel bronze strainer. (For non-membrane floors, use MIFAB F1100-Z Series).

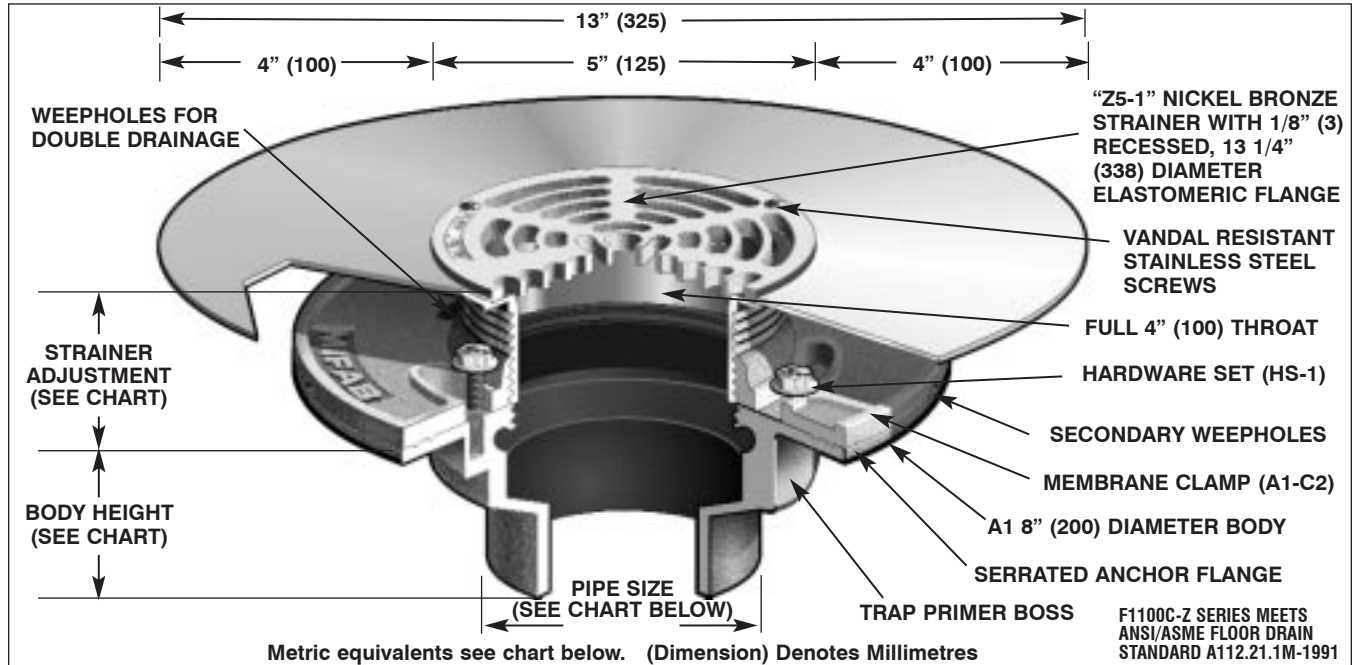

| STRAINER DIAMETER | STRAINER ADJUSTMENT |               | ANSI/ASME RATING                          |                        | PIPE SIZE                                  | NO HUB   | BODY HEIGHT                                    |  |  |
|-------------------|---------------------|---------------|---|------------------------|--|--|--|--|--|
|                   | MIN                 | MAX           | FREE AREA                                 | LOAD RATING N.B. (-1)  |  |  | PUSH ON (P)                                    | THREADED (T)                                   | INSIDE CAULK (X)                               |
| 5" (125)          | 1 9/16" (40)        | 2 11/16" (68) | 8 in <sup>2</sup><br>(5200 <sup>2</sup> ) | UP TO<br>2,000<br>LBS. | 2" (50)<br>3" (75)<br>4" (100)<br>6" (150) | 2 3/4" (70)<br>2 3/4" (70)<br>2 3/4" (70)<br>3 1/4" (83) | 3 3/8" (86)<br>3 3/8" (86)<br>3 3/8" (86)<br>— | 2 1/4" (57)<br>2 5/8" (67)<br>2 5/8" (67)<br>— | 2 3/4" (70)<br>2 3/4" (70)<br>2 3/4" (70)<br>— |

### OPTIONAL VARIATIONS:

- |  |  |   |  |
|--|--|---|--|
| <ul style="list-style-type: none"> <li><input type="checkbox"/> Nickel bronze</li> <li><input type="checkbox"/> <b>Stainless steel strainer</b></li> <li><input type="checkbox"/> 3M epoxy finish</li> <li><input type="checkbox"/> Sediment bucket</li> <li><input type="checkbox"/> Vandal proof</li> <li><input type="checkbox"/> Trap seal primer tapping</li> <li><input type="checkbox"/> Backwater valve</li> <li><input type="checkbox"/> Acid resistant epoxy coating</li> <li><input type="checkbox"/> All galvanized</li> <li><input type="checkbox"/> Extension</li> <li><input type="checkbox"/> Bronze body</li> <li><input type="checkbox"/> Stainless steel body (type 304)</li> <li><input type="checkbox"/> Stainless steel body (type 316)</li> <li><input type="checkbox"/> <b>PVC socket connection body</b></li> </ul> | <ul style="list-style-type: none"> <li>suffix -1</li> <li><b>suffix -3</b></li> <li>suffix -3M</li> <li>suffix -5</li> <li>suffix -6</li> <li>suffix -7</li> <li>suffix -8</li> <li>suffix -11</li> <li>suffix -13</li> <li>suffix -15</li> <li>suffix -27</li> <li>suffix -28</li> <li>suffix -29</li> <li><b>suffix -30</b></li> </ul> | <ul style="list-style-type: none"> <li><input type="checkbox"/> <b>ABS socket connection body</b></li> <li><input type="checkbox"/> Closure plug</li> <li><input type="checkbox"/> Deck clamp</li> <li><input type="checkbox"/> Sump receiver</li> <li><input type="checkbox"/> Threaded side outlet</li> <li><input type="checkbox"/> Client logo</li> <li><input type="checkbox"/> Clamp ring for low rough-in (min. 1/2" (13))</li> <li><input type="checkbox"/> 4" Round funnel</li> <li><input type="checkbox"/> 6" Round funnel</li> <li><input type="checkbox"/> Oval 4" x 9" funnel</li> <li><input type="checkbox"/> 6" x 3" x 1" funnel</li> <li><input type="checkbox"/> Push on outlet</li> <li><input type="checkbox"/> Threaded outlet</li> <li><input type="checkbox"/> Inside caulk outlet</li> </ul> | <ul style="list-style-type: none"> <li><b>suffix -31</b></li> <li>suffix -34</li> <li>suffix -40</li> <li>suffix -41</li> <li>suffix -90</li> <li>suffix -95</li> <li>suffix C1</li> <li>suffix -F4</li> <li>suffix -F6</li> <li>suffix -G</li> <li>suffix -J</li> <li>suffix P</li> <li>suffix T</li> <li>suffix X</li> </ul> |
|--|--|---|--|

### PARTS:



A1 BODY



Z5-1



A1-C2

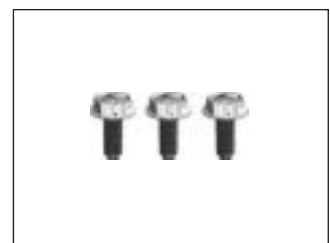

HS-1