



F1100C-SD

FLOOR DRAIN WITH SQUARE SOLID HINGED COVER FOR MEMBRANE FLOOR AREAS

Internet address: www.mifab.com

Toll Free: 1-800-465-2736

Canada Toll Free: 1-800-387-3880

SPECIFICATION: MIFAB Series F1100C-SD6-1 lacquered cast iron floor drain with anchor flange, cast iron membrane clamp ring with primary and secondary weepholes for waterproofing membrane, and standard reinforced, ("SD6") square 6" x 6" (150 x 150) nickel bronze strainer with solid hinged cover and secondary grate. (For non-membrane floors, use MIFAB F1100-SD6 Series).

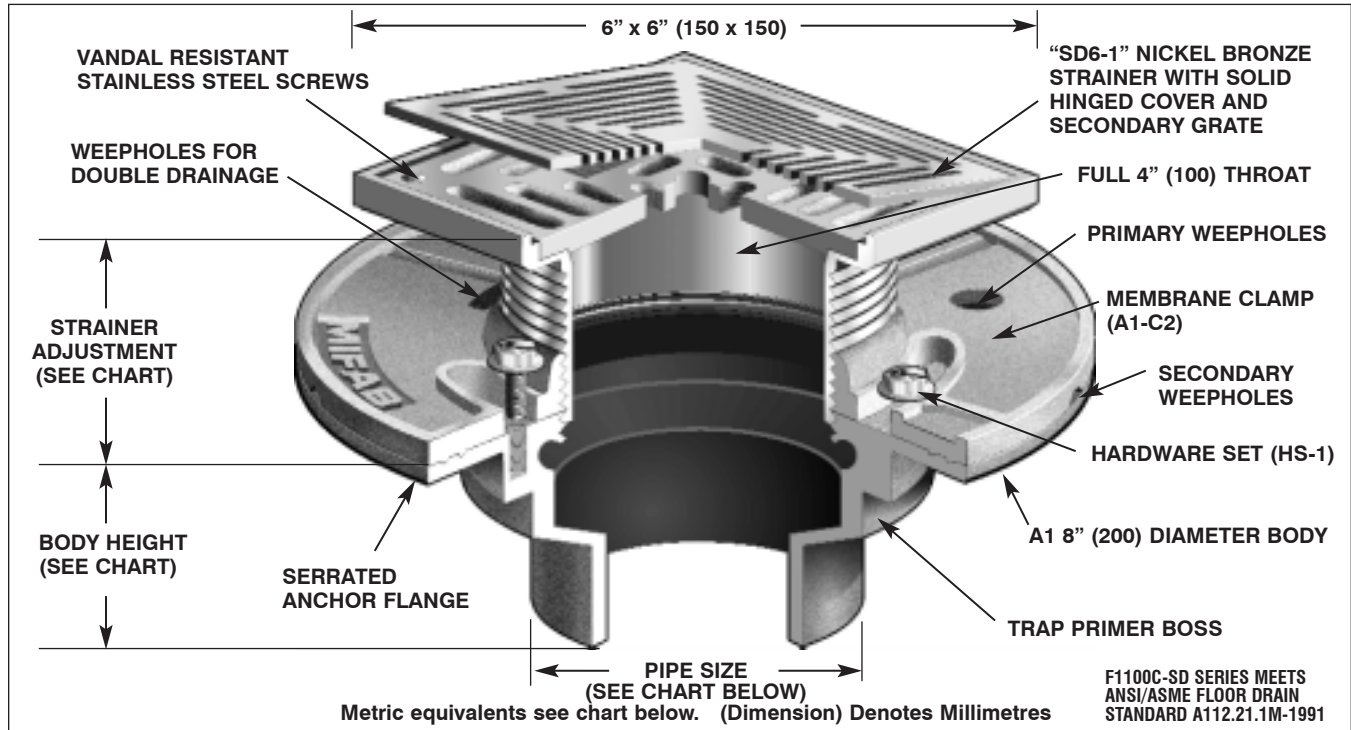

STRAINER SIZE	STRAINER ADJUSTMENT		ANSI/ASME RATING		PIPE SIZE	NO HUB	BODY HEIGHT		
	MIN	MAX	FREE AREA	LOAD RATING N.B.(-1)			PUSH ON (P)	THREADED (T)	INSIDE CAULK (X)
6" x 6" (150 x 150)	2" (50)	3 1/8" (79)	12 in ² (7700 ²)	UP TO 2,000 LBS.	2" (50)	2 3/4" (70)	3 3/8" (86)	2 1/4" (57)	2 3/4" (70)
					3" (75)	2 3/4" (70)	3 3/8" (86)	2 5/8" (67)	2 3/4" (70)
					4" (100)	2 3/4" (70)	3 3/8" (86)	2 5/8" (67)	2 3/4" (70)
					6" (150)	3 1/4" (83)	—	—	—

OPTIONAL VARIATIONS:

- Nickel bronze (standard)
 - Stainless steel strainer**
 - 3M epoxy finish
 - Sediment bucket
 - Vandal proof
 - Trap seal primer tapping
 - Backwater valve
 - Acid resistant epoxy coating
 - All galvanized
 - Extension
 - Bronze body
 - Stainless steel body (type 304)
- suffix -1
 - suffix -3
 - suffix -3M
 - suffix -5
 - suffix -6
 - suffix -7
 - suffix -8
 - suffix -11
 - suffix -13
 - suffix -15
 - suffix -27
 - suffix -28
- Stainless steel body (type 316)
 - PVC socket connection body**
 - ABS socket connection body**
 - Closure plug
 - Deck clamp
 - Sump receiver
 - Threaded side outlet
 - Client logo
 - Clamp ring for low rough-in (min. 15/16" (24))
 - Push on outlet
 - Threaded outlet
 - Inside caulk outlet
 - Elastomeric flange
- suffix -29
 - suffix -30
 - suffix -31
 - suffix -34
 - suffix -40
 - suffix -41
 - suffix -90
 - suffix -95
 - suffix C1
 - suffix P
 - suffix T
 - suffix X
 - suffix -Z

PARTS:

