



F1100-ZS

FLOOR DRAIN WITH SQUARE STRAINER AND ELASTOMERIC FLANGE FOR NON MEMBRANE FLOOR AREAS

Internet address: www.mifab.com

Toll Free: 1-800-465-2736

Canada Toll Free: 1-800-387-3880

SPECIFICATION: MIFAB Series F1100-ZS-1 lacquered cast iron floor drain with anchor flange, weepholes and 1/8" (3) recessed, 13 1/4" (338) square elastomeric flange, with standard reinforced 6" x 6" (150 x 150) square satin finished nickel bronze strainer. (For membrane floors, use MIFAB F1100C-ZS Series).

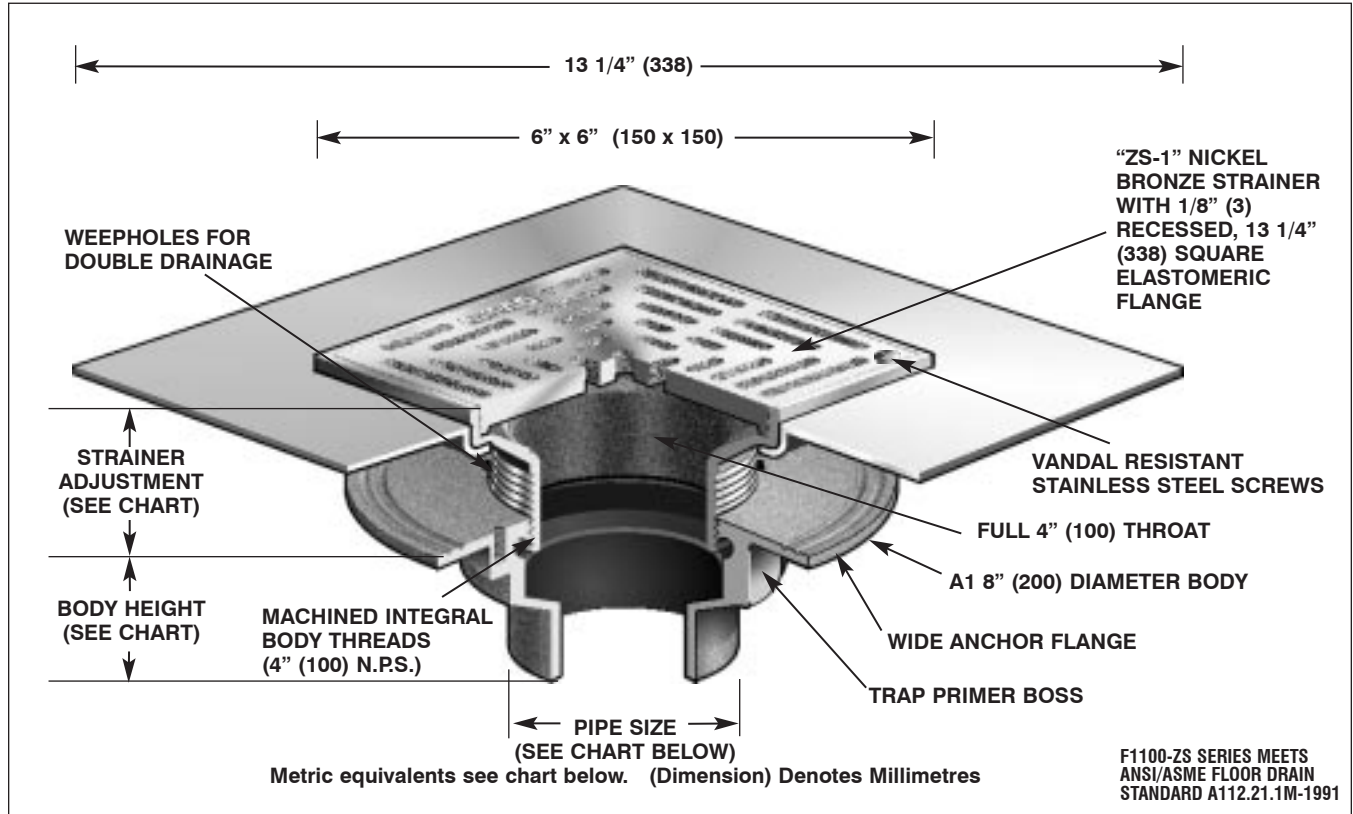

STRAINER SIZE	STRAINER ADJUSTMENT		ANSI/ASME RATING		PIPE SIZE	NO HUB	BODY HEIGHT PUSH ON (P)	THREADED (T)	INSIDE CAULK (X)
	MIN	MAX	FREE AREA	LOAD RATING N.B. (-1)					
6" x 6" (150 x 150)	7/8" (22)	1 9/16 (40)	12 in ² (7700 ²)	UP TO 2,000 LBS.	2" (50)	2 3/4" (70)	3 3/8" (86)	2 1/4" (57)	2 3/4" (70)
					3" (75)	2 3/4" (70)	3 3/8" (86)	2 5/8" (67)	2 3/4" (70)
					4" (100)	2 3/4" (70)	3 3/8" (86)	2 5/8" (67)	2 3/4" (70)
					6" (150)	3 1/4" (83)	—	—	—

OPTIONAL VARIATIONS:

- Nickel bronze
- Stainless steel strainer**
- 3M epoxy finish
- Sediment bucket
- Vandal proof
- Trap seal primer tapping
- Backwater valve
- Acid resistant epoxy coating
- All galvanized

- suffix -1
- suffix -3**
- suffix -3M
- suffix -5
- suffix -6
- suffix -7
- suffix -8
- suffix -11
- suffix -13

- Extension
- Bronze body
- Stainless steel body (type 304)
- Stainless steel body (type 316)
- PVC socket connection body**
- ABS socket connection body**
- Closure plug
- Deck clamp
- Sump receiver
- Threaded side outlet
- Client logo
- 4" Round funnel
- 6" Round funnel
- Oval 4" x 9" funnel
- 6" x 3" x 1" funnel
- Push on outlet
- Threaded outlet
- Inside caulk outlet

- suffix -15
- suffix -27
- suffix -28
- suffix -29
- suffix -30**
- suffix -31**
- suffix -34
- suffix -40
- suffix -41
- suffix -90
- suffix -95
- suffix -F4
- suffix -F6
- suffix -G
- suffix -J
- suffix P
- suffix T
- suffix X

PARTS:

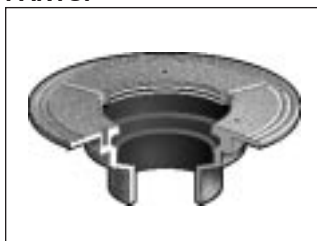

A1 BODY



ZS-1