



# F1350

## FLOOR DRAIN WITH 12" ROUND ADJUSTABLE TRACTOR GRATE AND EXTRA DEEP SUMP

Internet address: [www.mifab.com](http://www.mifab.com)

Toll Free: 1-800-465-2736

Canada Toll Free: 1-800-387-3880

**SPECIFICATION:** MIFAB Series F1350-4 lacquered cast iron floor drain with anchor flange, weepholes, and adjustable collar with extra deep sump body and standard 1" (25) thick, 12" (300) round, ductile iron tractor grate.

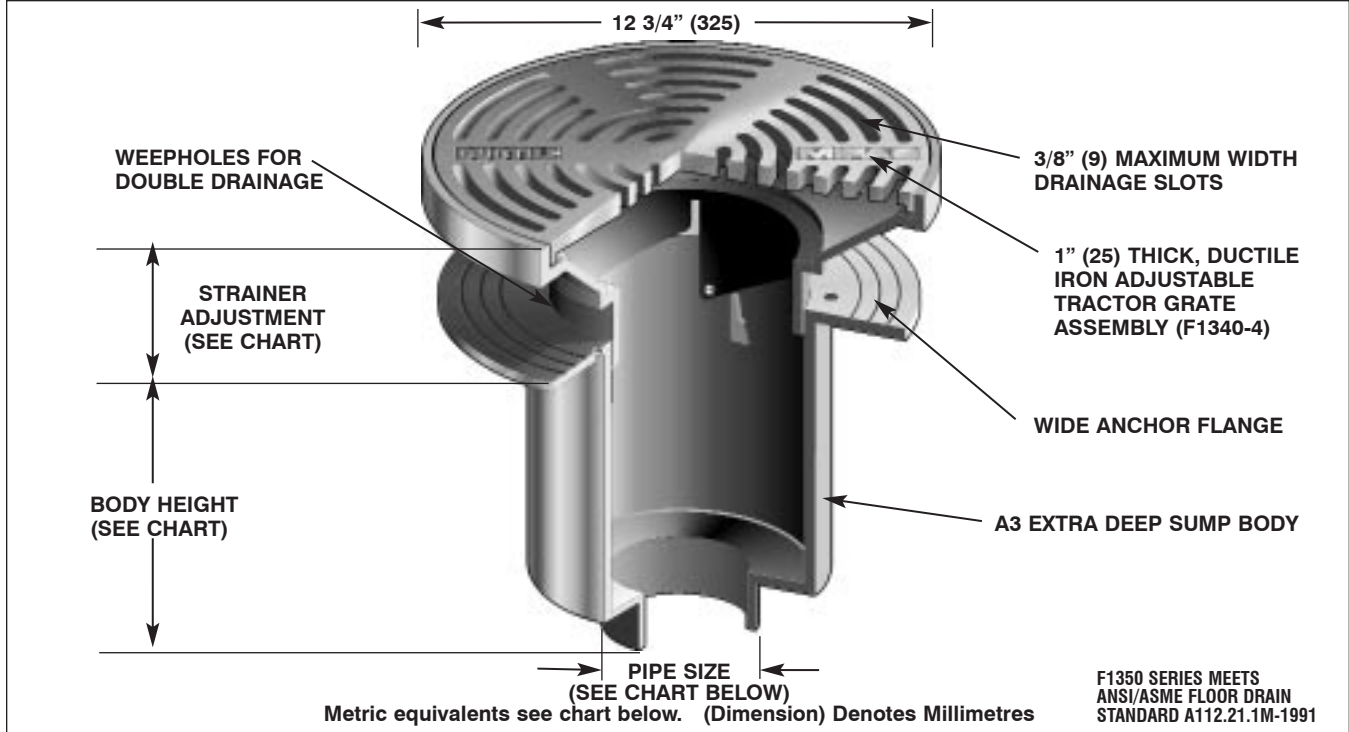

STRAINER DIAMETER	STRAINER ADJUSTMENT		ANSI/ASME RATING		PIPE SIZE	BODY HEIGHT			INSIDE CAULK (X)
	MIN	MAX	FREE AREA	LOAD RATING		NO HUB	PUSH ON (P)	THREADED (T)	
12" (300)	2 1/4" (57)	4 1/8" (105)	33 in <sup>2</sup> (21,290 <sup>2</sup> )	ANSI/ASME	2" (50)	12" (300)	12 3/4" (325)	11 1/2" (292)	12" (300)
				LOAD CLASS	3" (75)	12" (300)	12 3/4" (325)	11 7/8" (300)	12" (300)
				"SPECIAL DUTY" (OVER 10,000 LBS.)	4" (100)	12" (300)	12 3/4" (325)	11 7/8" (300)	12" (300)
					6" (150)	12" (300)	—	—	—

**OPTIONAL VARIATIONS:**

- Nickel bronze (vener)
- Stainless steel (vener)**
- 3M epoxy finish
- Ductile iron grate (standard)
- Sediment bucket
- Vandal proof
- Trap seal primer tapping
- Backwater valve
- Acid resistant epoxy coating
- Galvanized grate and frame
- All galvanized
- Non tilt grate
- Extension

- suffix -1
- suffix -3**
- suffix -3M
- suffix -4
- suffix -5
- suffix -6
- suffix -7
- suffix -8
- suffix -11
- suffix -12
- suffix -13
- suffix -14
- suffix -15

- Square top
- Dome grate
- Secondary dome
- Secondary strainer
- Chained grate
- Solid secured cover
- PVC socket connection body outlet**
- ABS socket connection body outlet**
- Closure plug
- Bronze mesh bucket
- Can wash assembly package
- Deck clamp
- Sump receiver
- Lacquered cast iron funnels
- Threaded side outlet
- Client logo
- Membrane clamp
- Round 4" funnel
- Round 6" funnel
- Oval 4" x 9" funnel
- 6" x 3" x 1" funnel
- Push on outlet
- Threaded outlet
- Inside caulk outlet
- Non adjustable top
- Elastomeric flange

- suffix -16
- suffix -18
- suffix -20
- suffix -21
- suffix -23
- suffix -24
- suffix -30**
- suffix -31**
- suffix -34
- suffix -35
- suffix -36
- suffix -40
- suffix -41
- suffix -50
- suffix -90
- suffix -95
- suffix C
- suffix -F4
- suffix -F6
- suffix -G
- suffix -J
- suffix P
- suffix T
- suffix X
- suffix -Y
- suffix -Z

**PARTS:**



A3 BODY



F1340-4