



F1100-N7/F1100-N9

FLOOR DRAIN WITH 7" OR 9" TRACTOR GRATE FOR NON-MEMBRANE FLOOR AREAS

Internet address: www.mifab.com

Toll Free: 1-800-465-2736

Canada Toll Free: 1-800-387-3880

SPECIFICATION: MIFAB Series F1100-N() lacquered cast iron floor drain with anchor flange, weepholes, and 7" (175) or 9" (230) (specify N7 or N9) satin finished nickel bronze tractor grate. (For membrane floors, use MIFAB F1100C-N Series)

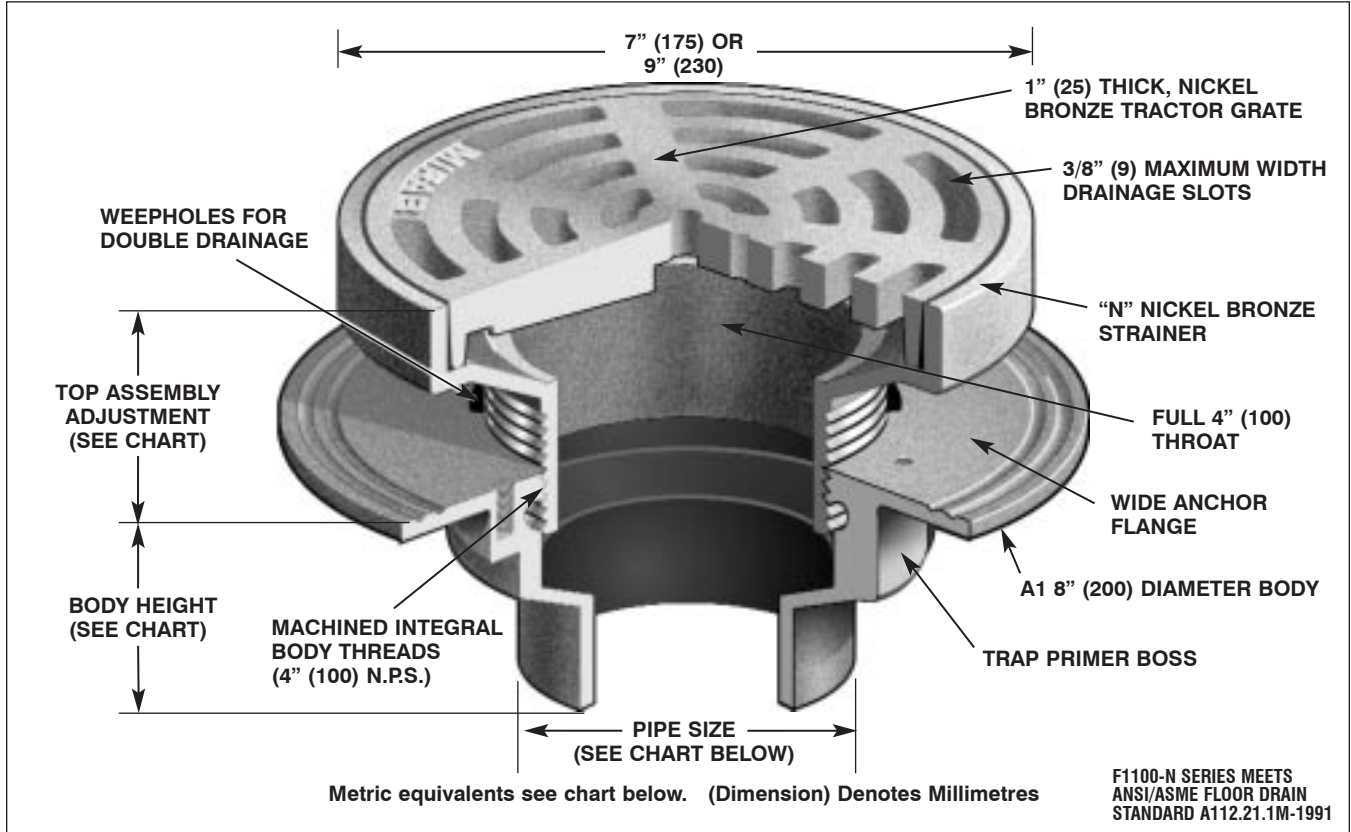

STRAINER DIAMETER	STRAINER ADJUSTMENT		ANSI/ASME RATING		PIPE SIZE	NO HUB	BODY HEIGHT PUSH ON (P)	THREADED (T)	INSIDE CAULK (X)
	MIN	MAX	FREE AREA	LOAD RATING					
7" (175)	1 5/8" (41)	2 5/8" (67)	11.00 in ² (7096 ²)	ANSI/ASME LOAD CLASS	2" (50) 3" (75)	2 3/4" (70) 2 3/4" (70)	3 3/8" (86) 3 3/8" (86)	2 1/4" (57) 2 5/8" (67)	2 3/4" (70) 2 3/4" (70)
9" (230)	1 5/8" (41)	2 5/8" (67)	18 in ² (11,613 ²)	"SPECIAL DUTY" (OVER 10,000 LBS.)	4" (100) 6" (150)	2 3/4" (70) 3 1/4" (83)	3 3/8" (86) —	2 5/8" (67) —	2 3/4" (70) —

OPTIONAL VARIATIONS:

- Nickel bronze (standard)
- Stainless steel strainer (vener)**
- 3M epoxy finish
- Ductile iron strainer assembly
- Sediment bucket
- Vandal proof
- Trap seal primer tapping
- Backwater valve
- Acid resistant epoxy coating

- suffix -1
- suffix -3**
- suffix -3M
- suffix -4
- suffix -5
- suffix -6
- suffix -7
- suffix -8
- suffix -11

- Galvanized top assembly
- All galvanized
- Extension
- Bronze body
- Stainless steel body (type 304)
- Stainless steel body (type 316)
- PVC socket connection body**
- ABS socket connection body**
- Closure plug
- Deck clamp
- Sump receiver
- Lacquered cast iron (funnels only)
- Threaded side outlet
- Client logo
- 4" Round funnel
- 6" Round funnel
- Oval 4" x 9" funnel
- 6" x 3" x 1" funnel
- Push on outlet
- Threaded outlet
- Inside caulk outlet
- Elastomeric flange

- suffix -12
- suffix -13
- suffix -15
- suffix -27
- suffix -28
- suffix -29
- suffix -30**
- suffix -31**
- suffix -34
- suffix -40
- suffix -41
- suffix -50
- suffix -90
- suffix -95
- suffix -F4
- suffix -F6
- suffix -G
- suffix -J
- suffix P
- suffix T
- suffix X
- suffix -Z

PARTS:

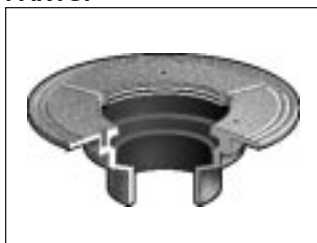

A1 BODY



N (specify 7" or 9")