



F1300C

FLOOR DRAIN WITH 7" ROUND ADJUSTABLE TRACTOR GRATE

Internet address: www.mifab.com

Toll Free: 1-800-465-2736

Canada Toll Free: 1-800-387-3880

SPECIFICATION: MIFAB Series F1300C-4 lacquered cast iron floor drain with anchor flange, cast iron clamp ring with primary and secondary weepholes for waterproofing membrane, and standard 1" (25) thick, 7" (175) round, ductile iron tractor grate. (For non-membrane floors, use MIFAB F1300 Series).

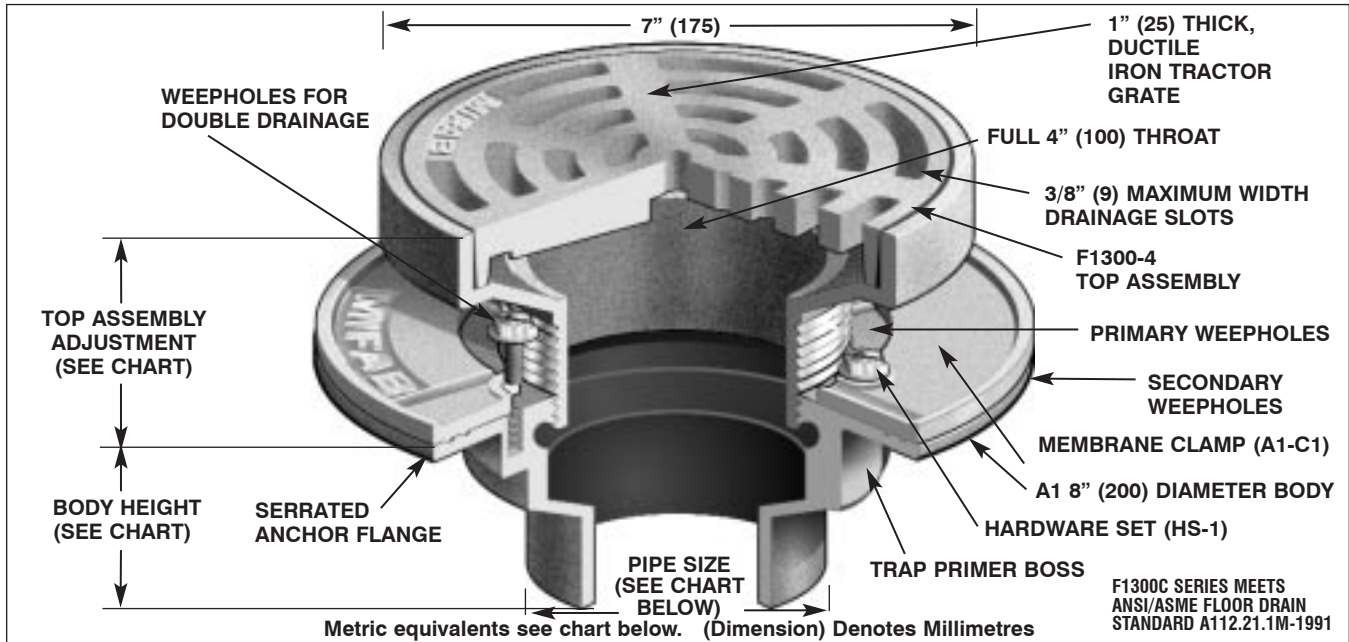

STRAINER DIAMETER	STRAINER ADJUSTMENT		ANSI/ASME RATING		PIPE SIZE	NO HUB	PUSH ON (P)	BODY HEIGHT THREADED (T)	INSIDE CAULK (X)
	MIN	MAX	FREE AREA	LOAD RATING					
7" (175)	1 5/8" (41)	2 5/8" (67)	11.00 in ² (7096 ²)	ANSI/ASME	2" (50)	2 3/4" (70)	3 3/8" (86)	2 1/4" (57)	2 3/4" (70)
				LOAD CLASS	3" (75)	2 3/4" (70)	3 3/8" (86)	2 5/8" (67)	2 3/4" (70)
				"SPECIAL DUTY"	4" (100)	2 3/4" (70)	3 3/8" (86)	2 5/8" (67)	2 3/4" (70)
				(OVER 10,000 LBS.)	6" (150)	3 1/4" (83)	—	—	—

OPTIONAL VARIATIONS:

- Nickel bronze
- 3M epoxy finish
- Stainless steel strainer (veneer)**
- Ductile iron grate (standard)
- Sediment bucket
- Vandal proof
- Trap seal primer tapping
- Backwater valve
- Acid resistant epoxy coating
- Galvanized top assembly
- All galvanized
- Non tilt grate
- Extension
- Square top
- Bronze body
- Stainless steel body (type 304)
- Stainless steel body (type 316)

- suffix -1
- suffix -3M
- suffix -3**
- suffix -4
- suffix -5
- suffix -6
- suffix -7
- suffix -8
- suffix -11
- suffix -12
- suffix -13
- suffix -14
- suffix -15
- suffix -16
- suffix -27
- suffix -28
- suffix -29

- PVC socket connection body
- ABS socket connection body**
- Closure plug
- Deck clamp
- Sump receiver
- Lacquered cast iron funnels
- Threaded side outlet
- Client logo
- Less membrane clamp, Delete**
- 4" Round funnel
- 6" Round funnel
- Oval 4" x 9" funnel
- 6" x 3" x 1" funnel
- Push on outlet
- Threaded outlet
- Inside caulk outlet
- Non adjustable top
- Elastomeric flange

- suffix -30**
- suffix -31**
- suffix -34
- suffix -40
- suffix -41
- suffix -50
- suffix -90
- suffix -95
- suffix C**
- suffix -F4
- suffix -F6
- suffix -G
- suffix -J
- suffix P
- suffix T
- suffix X
- suffix -Y
- suffix -Z

PARTS:

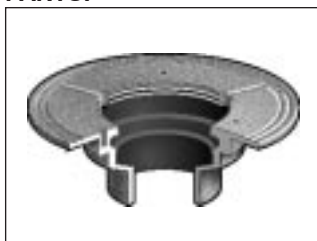

A1 BODY



F1300-4



A1-C1

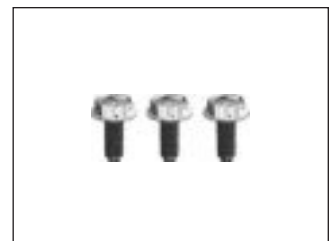

HS-1