



# F1420C

## FLOOR DRAIN WITH 8" SQUARE ADJUSTABLE TRACTOR GRATE

Internet address: [www.mifab.com](http://www.mifab.com)

Toll Free: 1-800-465-2736

Canada Toll Free: 1-800-387-3880

**SPECIFICATION:** MIFAB Series F1420C-4 lacquered cast iron floor drain with anchor flange, cast iron clamp ring with primary and secondary weepholes for waterproofing membrane, and standard 1" (25) thick, 8" (200) square, ductile iron tractor grate. (For non-membrane floors, use MIFAB F1420 Series).

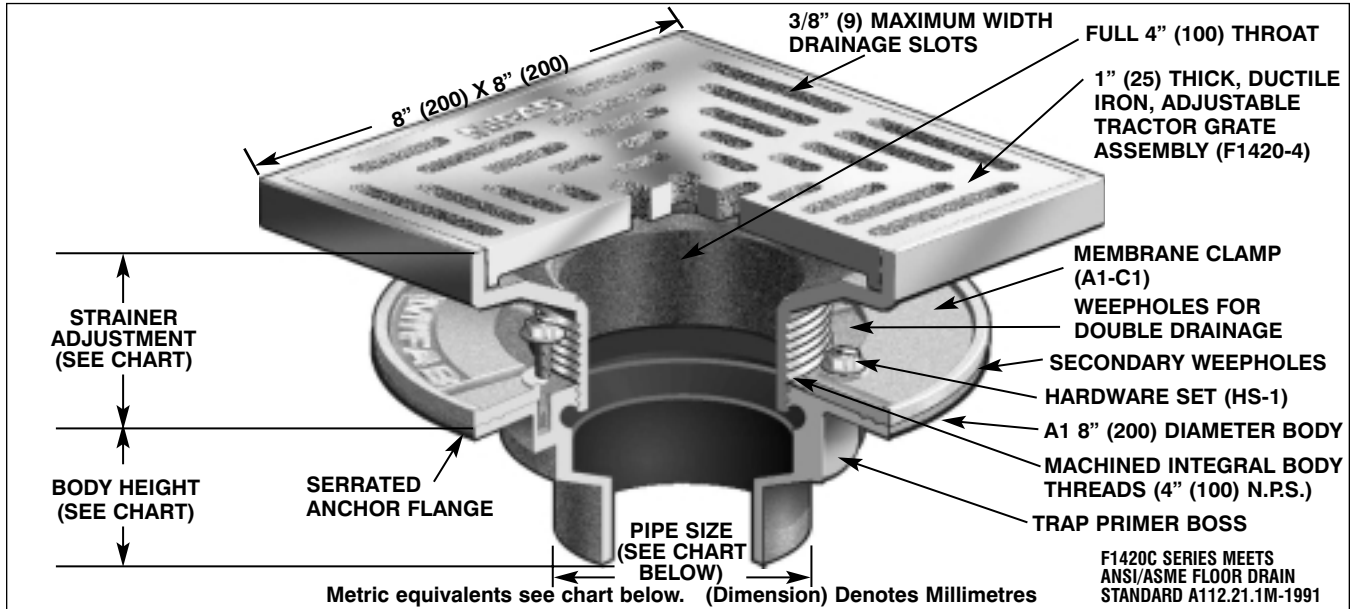

STRAINER SIZE	STRAINER ADJUSTMENT		ANSI/ASME RATING		PIPE SIZE	NO HUB	BODY HEIGHT PUSH ON (P)	THREADED (T)	INSIDE CAULK (X)
	MIN	MAX	FREE AREA	LOAD RATING					
8" x 8" (200) x (200)	1 3/4" (45)	2 5/8" (67)	26 in. <sup>2</sup> (26800 <sup>2</sup> )	ANSI/ASME	2" (50)	2 3/4" (70)	3 3/8" (86)	2 1/4" (57)	2 3/4" (70)
				LOAD CLASS	3" (75)	2 3/4" (70)	3 3/8" (86)	2 5/8" (67)	2 3/4" (70)
				"SPECIAL DUTY"	4" (100)	2 3/4" (70)	3 3/8" (86)	2 5/8" (67)	2 3/4" (70)
				(OVER 10,000 LBS.)	6" (150)	3 1/4" (83)	—	—	—

**OPTIONAL VARIATIONS:**

- Nickel bronze (vener)
- Stainless steel (vener)**
- 3M epoxy finish
- Ductile iron grate (standard)
- Sediment bucket
- Vandal proof
- Trap seal primer tapping
- Backwater valve
- Acid resistant epoxy coating
- Galvanized grate and frame
- All galvanized
- Non tilt grate
- Extension
- Chained grate
- Bronze body
- Stainless steel body (type 304)
- Stainless steel body (type 316)

- suffix -1
- suffix -3
- suffix -3M
- suffix -4
- suffix -5
- suffix -6
- suffix -7
- suffix -8
- suffix -11
- suffix -12
- suffix -13
- suffix -14
- suffix -15
- suffix -23
- suffix -27
- suffix -28
- suffix -29

- PVC socket connection body
- ABS socket connection body
- Closure plug
- Deck clamp
- Sump receiver
- Lacquered cast iron funnels
- Threaded side outlet
- Client logo
- Less membrane clamp, Delete**
- Round 4" funnel
- Round 6" funnel
- Oval 4" x 9" funnel
- 6" x 3" x 1" funnel
- Push on outlet
- Threaded outlet
- Inside caulk outlet
- Non adjustable top
- Elastomeric flange

- suffix -30
- suffix -31
- suffix -34
- suffix -40
- suffix -41
- suffix -50
- suffix -90
- suffix -95
- suffix C
- suffix -F4
- suffix -F6
- suffix -G
- suffix -J
- suffix P
- suffix T
- suffix X
- suffix -Y
- suffix -Z

**PARTS:**

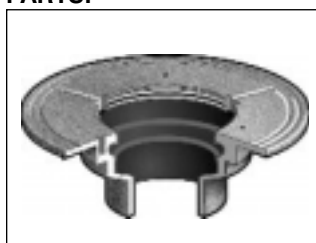

A1 BODY



F1420-4



A1-C1

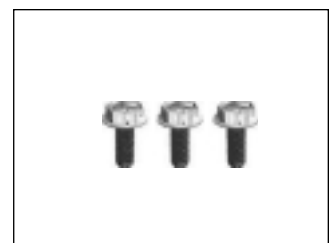

HS-1