



**F1230-WF**

**WOOD DECK FLOOR DRAIN**

Internet address: [www.mifab.com](http://www.mifab.com)

Toll Free: 1-800-465-2736

Canada Toll Free: 1-800-387-3880

**SPECIFICATION:** MIFAB Series F1230-WF-1 lacquered cast iron wood floor drain with 1 1/2" (38) wide securing flange, and standard, reinforced, 5" (125) diameter nickel bronze rim and grate.

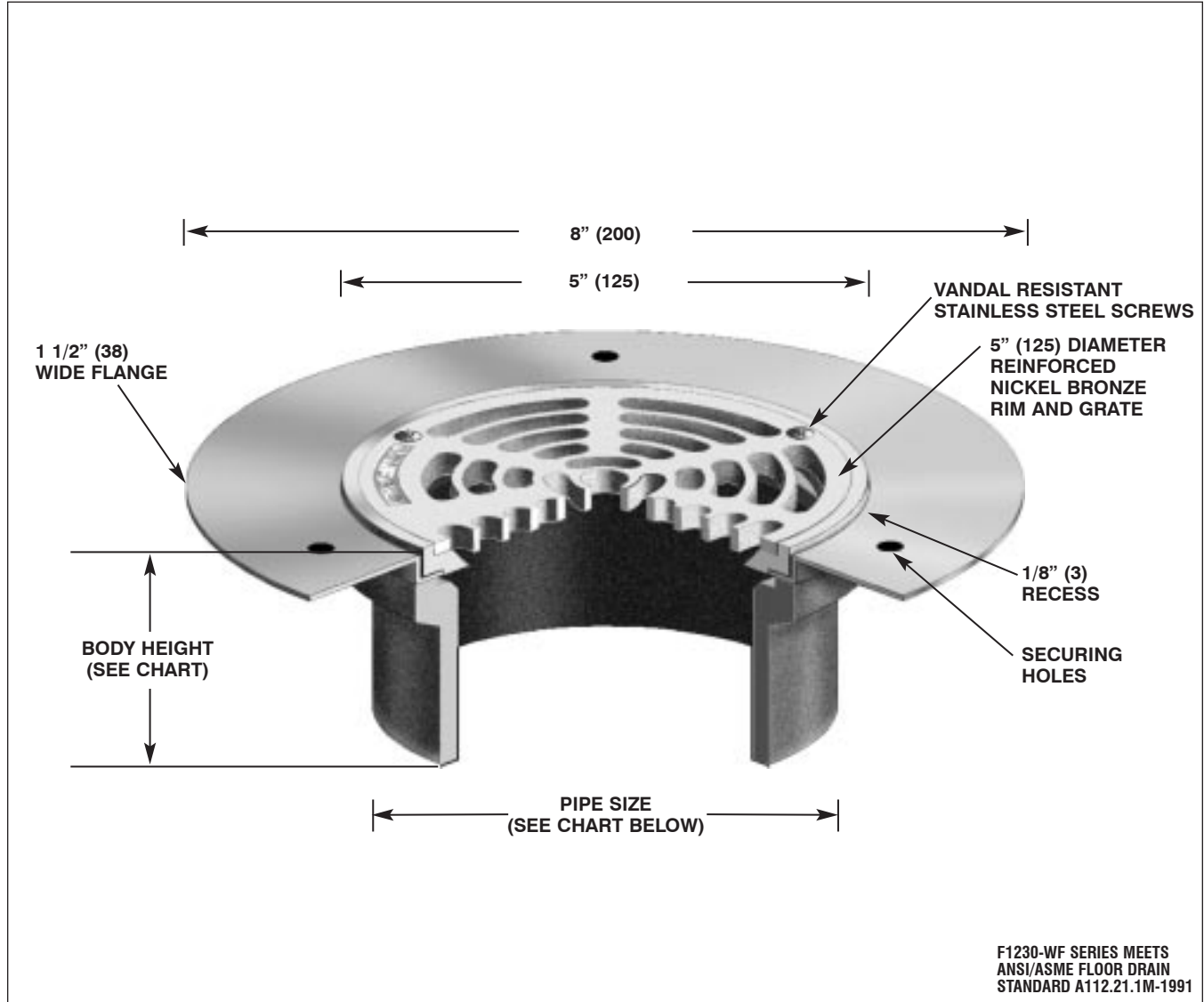

STRAINER DIAMETER	ANSI/ASME RATING		PIPE SIZE	CAST IRON BODY (NH)	BODY HEIGHT		ABS BODY (-31)
	FREE AREA	LOAD RATING			PVC BODY (-30)	ABS BODY (-31)	
		N.B. (-1)	D.I. (-4)				
5" (125)	8 in <sup>2</sup> (5200 <sup>2</sup> )	UP TO	UP TO	2" (50)	2 1/2" (63)	2 15/16" (75)	2 15/16" (75)
		2,000 LBS.	7,499 LBS.	3" (75)	2 1/2" (63)	2 15/16" (75)	2 15/16" (75)
				4" (100)	2 1/2" (63)	2 15/16" (75)	2 15/16" (75)

**OPTIONAL VARIATIONS:**

- Nickel bronze (standard)
- 3M epoxy finish
- Ductile iron grate
- Sediment bucket
- Vandal proof
- Backwater valve
- Acid resistant epoxy coating

- suffix -1
- suffix -3M
- suffix -4
- suffix -5
- suffix -6
- suffix -8
- suffix -11

- PVC socket connection body
- ABS socket connection body
- Lacquered cast iron funnels
- Round 4" funnel
- Round 6" funnel
- Oval 4" x 9" funnel
- 6" x 3" x 1" funnel

- suffix -30
- suffix -31
- suffix -50
- suffix -F4
- suffix -F6
- suffix -G
- suffix -J