

F1560 SERIES

12" x 12" HEAVY DUTY AREA DRAIN WITH INTERNAL TRAP & SEDIMENT BUCKET F1560 SERIES

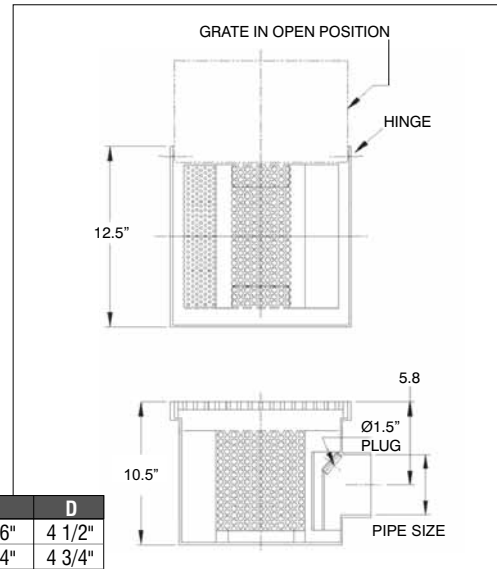
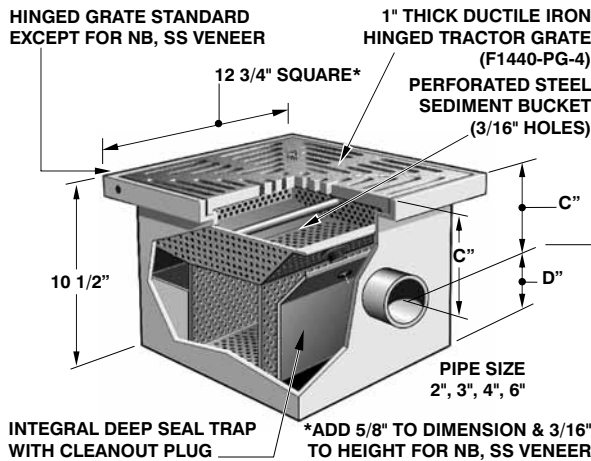

12" x 12" HEAVY DUTY AREA DRAIN WITH INTERNAL TRAP			
MODEL NUMBER	WT. Lbs	LACQUERED CAST IRON BODY WITH DUCTILE IRON (-4)	STAINLESS STEEL (VENEER) (-3)
F1562,3,4,6	50.00	\$1325.00	\$1891.00

	C	D
F1562	6"	4 1/2"
F1563	5 3/4"	4 3/4"
F1564	5 1/2"	5"
F1566	5 1/4"	5 1/4"

F1560 OPTIONAL VARIATIONS:

SUFFIX	DESCRIPTION	LIST PRICE	SUFFIX	DESCRIPTION	LIST PRICE
-6	Vandal proof secured grate (TR30 Torx and pin)	\$ 76.00	-13	Galvanized body and grate (Min. order 25 pcs. or P.O.A.)	\$753.00
-7	Trap Seal promer tapping	\$100.00	-28	Stainless Steel body (Type 304)	P.O.A.
-11	Acid resistant epoxy (Min. order 25 pcs. or P.O.A.)	\$872.00	-GS	Grounding strap	\$ 366.00
-12	Galvanized grate (Min. order 25 pcs. or P.O.A.)	\$377.00	-X	Invert extension "C" dimension, per inch	P.O.A.

F1570 OPTIONAL VARIATIONS:

SUFFIX	DESCRIPTION	LIST PRICE	SUFFIX	DESCRIPTION	LIST PRICE
-6	Vandal proof secured grate (Tr30 Torx and pin)	\$136.00	-SI	No hub side inlet	\$152.00
-13	All galvanized (Min. order 25 pcs. or P.O.A.)	\$977.00	-SIT	Side inlet with trap	\$305.00
-28	Stainless Steel body (Type 304)	P.O.A.	-X	Special "D" dimension, per inch	P.O.A.
-C	Membrane Clamp	\$305.00			

F1570 SERIES

24" x 24" HEAVY DUTY PARKING AREA CATCH BASIN F1570 SERIES

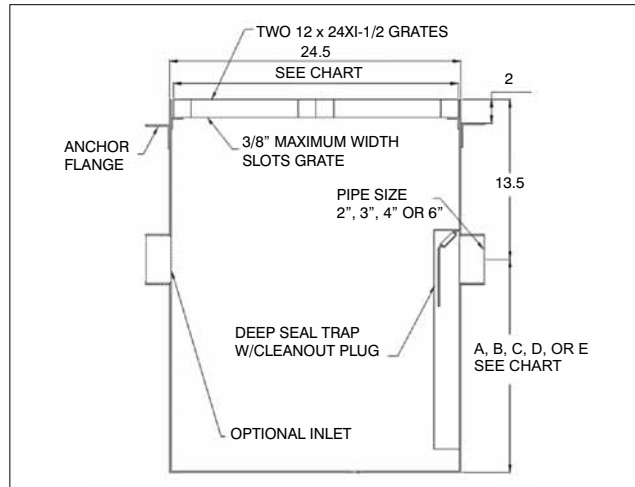
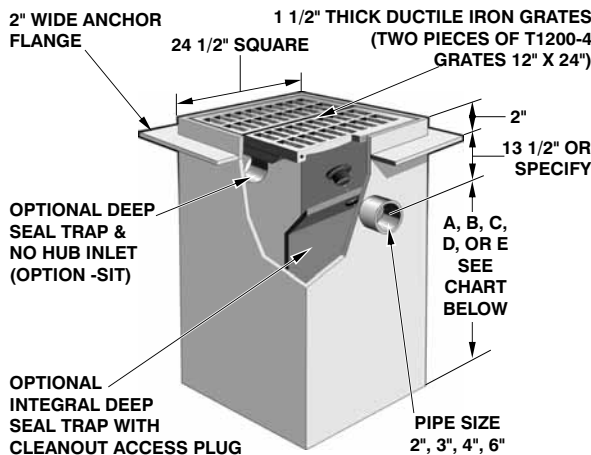

24" X 24" HEAVY DUTY PARKING AREA CATCH BASIN			
MODEL NUMBER	WT. Lbs	LIST PRICE BAKED EPOXY COATED STEEL BODY WITH: DUCTILE IRON (-4)	STAINLESS STEEL (VENEER) (-3)
F1572,3,4,6A	650.00	\$5097.00	P.O.A.
F1572,3,4,6B	872.00	\$5400.00	P.O.A.
F1572,3,4,6C	1100.00	\$5665.00	P.O.A.
F1572,3,4,6D	1300.00	\$6401.00	P.O.A.
F1572,3,4,6E	Varies	P.O.A.	P.O.A.

BODY DEPTH	
MODEL NO.	DEPTH
F1570A	18"
F1570B	24"
F1570C	30"
F1570D	36"
F1570E	SPECIAL

Design and dimensions are subject to modification. Prices do not include applicable taxes. Visit www.mifab.com for the most recent product information.

MIFAB, Inc., 1321 West 119th Street, Chicago, Illinois 60643-5109, USA

Toll Free 1-800-465-2736, Fax 773-341-3049

All sales subject to MIFAB's Terms and Warranties. Please refer to inside front cover.