

Specification: MIFAB® F1770 lacquered cast iron indirect waste drain with dome strainer and ductile iron grate.

Function: Used in non membrane floor and trench areas that have width limitations for surface drainage. Long rectangular grate has large free area to drain surface water quickly.

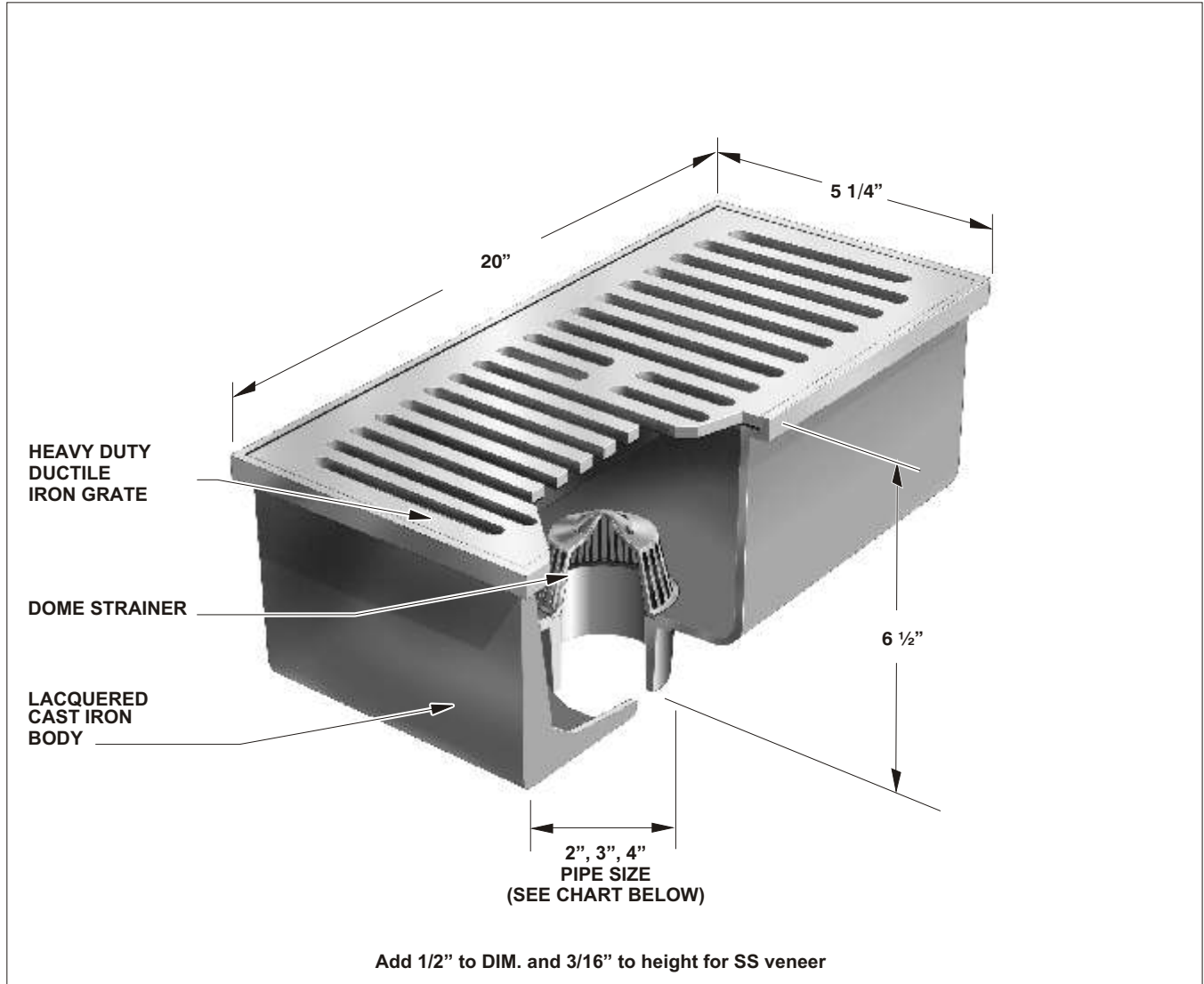

STRAINER SIZE	ANSI / ASME RATING		BODY HEIGHT				
	FREE AREA	LOAD RATING S.S. (-3) D.I. (-4)	PIPE SIZE	NO HUB (STANDARD)	PUSH ON (P)	THREADED (T)	INSIDE CAULK (X)
5 1/4" x 20" (133 x 508)	39 in ²	OVER 10,000 LBS	2" (51)	4" (102)	4 5/8" (118)	3 1/2" (89)	5" (127)
			3" (76)	4" (102)	4 5/8" (118)	3 7/8" (98)	5" (127)
			4" (102)	4" (102)	4 5/8" (118)	3 7/8" (98)	5" (127)

OPTIONAL VARIATIONS:

- Anchor flange
- Anchor flange with membrane clamp
- No hub outlet
- Stainless steel (vener)
- Vandal proof secured grate
- Trap seal primer tapping

SUFFIX

- FL
- FLC
- (Standard)
- 3
- 6
- 7
- Backwater valve
- Acid resistant epoxy coating
- All galvanized
- Push on outlet
- Threaded outlet
- Inside caulk outlet

SUFFIX

- 8
- 11
- 13
- P
- T
- X

Job Name _____	Page No: _____
Section No: _____	Contractor _____
Schedule No: _____	Purchase Order No: _____