

F1140C SERIES FLOOR DRAIN WITH 7" OR 9" ROUND TRACTOR GRATE, INTEGRAL DEEP SEAL TRAP & CLEANOUT

F1140C SERIES

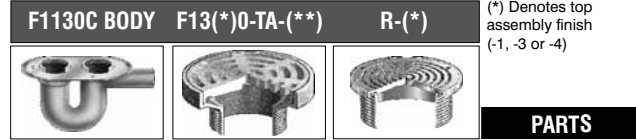
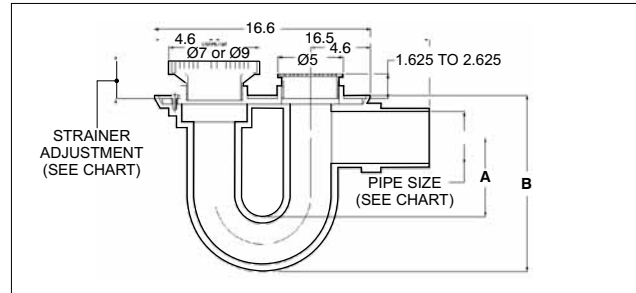
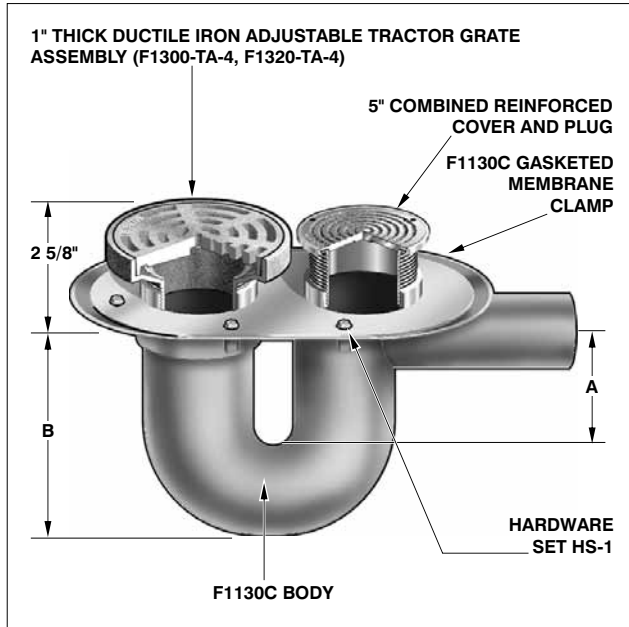

(*) Denotes top assembly finish (-1, -3 or -4)
 (**) Denotes strainer diameter (F1300 or F1320)
 (***) Denotes strainer finish (-1, -3, or -4)

SEE PAGE 26 FOR OPTIONAL VARIATIONS

ANSI/ASME RATING		
STRAINER	FREE AREA	LOAD RATING
F1300-TA-4	11.0 IN ²	OVER 10,000 lbs
F1320-TA-4	18.0 IN ²	OVER 10,000 lbs

FLOOR DRAIN WITH 7" OR 9" ROUND TRACTOR GRATE, INTEGRAL DEEP SEAL TRAP & CLEANOUT					
MODEL NUMBER	WT. Lbs	NO HUB OUTLET SIZE	STRAINER SIZE	LIST PRICE: NICKEL BRONZE (-1) STAINLESS STEEL (-3)	LIST PRICE DUCTILE IRON (-4)
F1142,3,4C-7	45.00	2", 3", 4"	7" DIA	\$1062.00	\$762.00
F1142,3,4C-9*	50.00	2", 3", 4"	9" DIA	\$1285.00	\$827.00

BODY HEIGHT		
PIPE SIZE	A	B
2" NO HUB	5 3/8"	13 1/2"
3" NO HUB	6"	13 1/2"
4" NO HUB	6 1/4"	13 1/2"

*ADD 3/8" TO 9" STRAINER DIAMETER AND 3/16" TO STRAINER HEIGHT FOR NB OR SS VENEER

FOR OPTIONAL STRAINERS, SEE PAGES 24 AND 25

FOR F1160 OPTIONAL VARIATIONS, SEE PAGE 28

F1160-C SERIES PRISON CELL FLOOR DRAIN

F1160-C SERIES

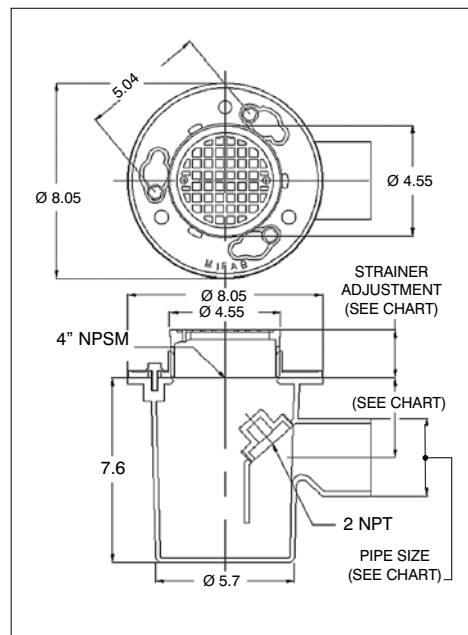
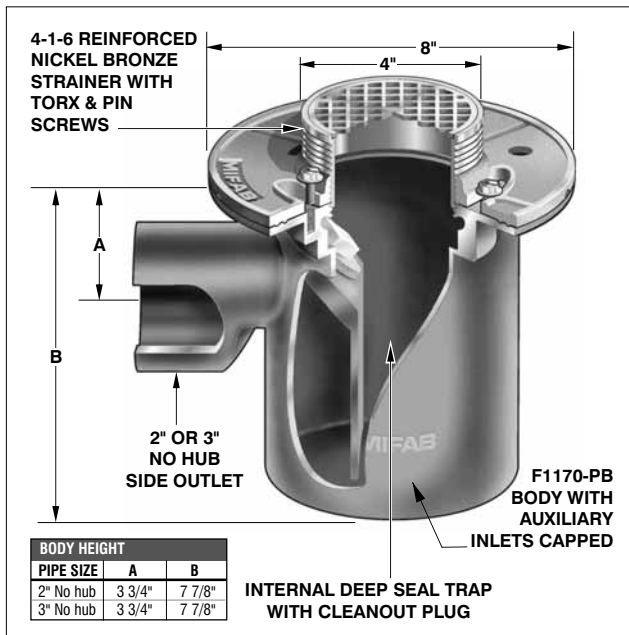

BODY HEIGHT		
PIPE SIZE	A	B
2" No hub	3 3/4"	7 7/8"
3" No hub	3 3/4"	7 7/8"

INTERNAL DEEP SEAL TRAP WITH CLEANOUT PLUG

PRISON CELL FLOOR DRAIN					
MODEL NUMBER	WT. Lbs	NO HUB OUTLET SIZE	STRAINER SIZE	LIST PRICE NICKEL BRONZE (-1)	LIST PRICE CHROME PLATED (-49)
F1162-C-4-1-6	13.00	2"	4" DIA	\$519.00	\$671.00
F1163-C-4-1-6	13.00	3"	4" DIA	\$576.00	\$728.00

ANSI/ASME RATING		
STRAINER	FREE AREA	LOAD RATING
4-1-6	3.5 IN ²	UP TO 2000 lbs

WHEN NO MEMBRANE CLAMP IS REQUIRED, DELETE SUFFIX (-C) AND DEDUCT \$43.00

Design and dimensions are subject to modification. Prices do not include applicable taxes. Visit www.mifab.com for the most recent product information.

MIFAB, Inc., 1321 West 119th Street, Chicago, Illinois 60643-5109, USA

Toll Free 1-800-465-2736, Fax 773-341-3049

All sales subject to MIFAB's Terms and Warranties. Please refer to inside front cover.

FLOOR DRAINS