

F1100-C-K FLOOR DRAIN WITH DOME STRAINER

F1100-C-K SERIES

SERIES

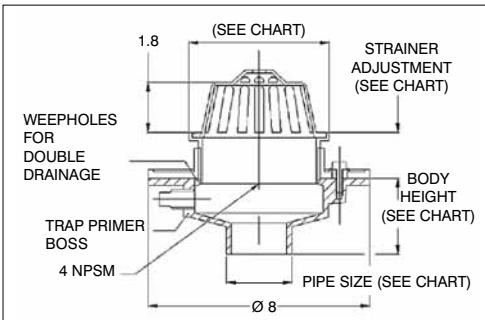
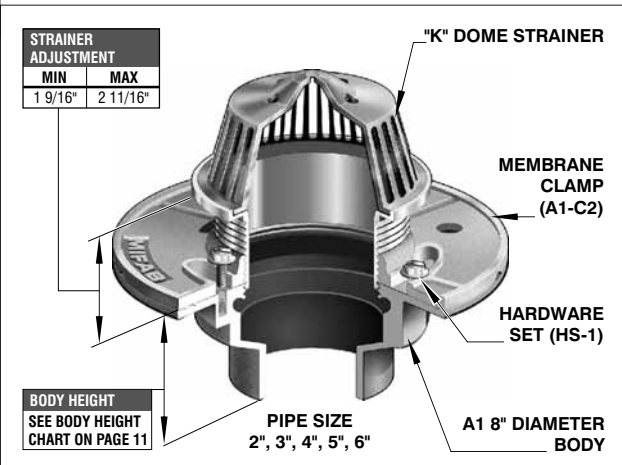

PARTS



(* Denotes strainer finish (-1, -3, or -50)

FLOOR DRAIN WITH DOME STRAINER

MODEL NUMBER	WT. Lbs	DOME SIZE	LIST PRICE		
			NICKEL BRONZE (-1)	STAINLESS STEEL (-3)	CAST IRON (-50)
F1102,3,4-C-K	9.00	5" DIA	\$349.00	\$349.00	\$185.00
F1102,3,4-C-K(*)-83	W/SS MESH OVER DOME, ADD TO ABOVE:				
					\$340.00

WHEN NO MEMBRANE CLAMP IS REQUIRED, DELETE SUFFIX (-C) AND DEDUCT \$43.00

ANSI/ASME RATING

FREE AREA
15 IN ²

F1100-C-K, F1100-C-N, F1100-C-RS AND F1100-C-S SERIES OPTIONAL VARIATIONS:

SUFFIX	DESCRIPTION	LIST PRICE	SUFFIX	DESCRIPTION	LIST PRICE
-5	Sediment bucket (A1-PB)	\$ 56.00	-21	Secondary flat strainer (FD-9600 Series)	\$ 31.00
-6	Security screws (TR25 torx and pin)	\$ 28.00	-28	Stainless Steel Body (Type 304) (2", 3", 4" No Hub)	P.O.A.
-7	Trap seal primer tapping	Standard	-30	PVC Socket Connection Body (2", 3" or 4")	No Add
-8	Backwater valve (BV1250 Series)	\$ 195.00	-31	ABS Socket Connection Body (2", 3" or 4")	No Add
-10	Decorative polished top (10 piece Min. order)	\$ 87.00	-34	Closure plug (C1440 Series)	\$ 187.00
-11	Acid resistant epoxy coated body (Min. order 25 pcs. or P.O.A)	\$ 133.00	-40	Underdeck clamp (A1-C3)	\$ 77.00
-13	Galvanized body (Min. order 25 pcs. or P.O.A)	\$ 101.00	-41	Sump receiver (A1-BP)	\$ 132.00
-15	Extension (DD-50)	\$ 71.00			

PVC/ABS Socket bodies available for 2", 3" or 4" connection sizes

F1100-C-N FLOOR DRAIN WITH 7" OR 9" TRACTOR GRATE

F1100-C-N SERIES

SERIES

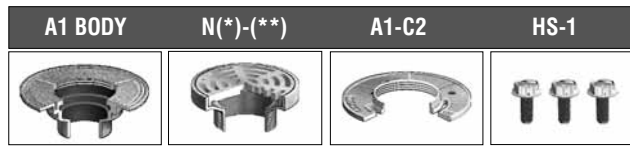
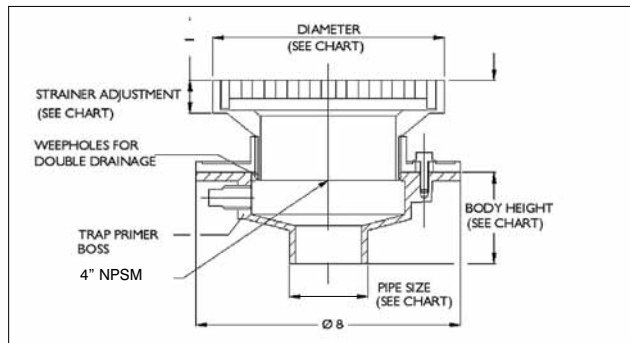
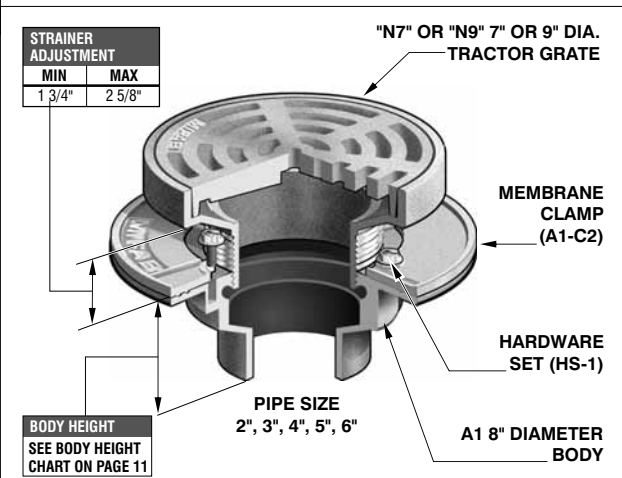

(* Denotes strainer diameter (7", or 9")
(**) Denotes strainer finish (-1, -3 or -4)

FLOOR DRAIN WITH 7" OR 9" TRACTOR GRATE

MODEL NUMBER	WT. Lbs	STRAINER SIZE	LIST PRICE		
			NICKEL BRONZE (-1)	STAINLESS STEEL (-3)	DUCTILE IRON (-4)
F1102,3,4-C-N7*	10.50	7" DIA	\$576.00	\$576.00	-
F1102,3,4-C-N7-4	10.50	7" DIA	-	-	\$276.00
F1102,3,4-C-N9*	11.50	9" DIA	\$797.00	\$797.00	-
F1102,3,4-C-N9-4	11.50	9" DIA	-	-	\$338.00

*ADD 3/8" TO DIAMETER AND 3/16" TO HEIGHT FOR (-1), (-3), NB OR SS VENEER
WHEN NO MEMBRANE CLAMP IS REQUIRED, DELETE SUFFIX (-C) AND DEDUCT \$43.00

ANSI/ASME RATING

STRAINER	FREE AREA	LOAD RATING
N7	11.0 IN ²	OVER 10000 lbs
N9	18.0 IN ²	OVER 10000 lbs

All sales subject to MIFAB's Terms and Warranties. Please refer to inside front cover.

Design and dimensions are subject to modification. Prices do not include applicable taxes. Visit www.mifab.com for the most recent product information.

MIFAB, Inc., 1321 West 119th Street, Chicago, Illinois 60643-5109, USA

Toll Free 1-800-465-2736, Fax 773-341-3049

All sales subject to MIFAB's Terms and Warranties. Please refer to inside front cover.