

F1100-C-SD FLOOR DRAIN WITH SQUARE SOLID HINGED COVER

F1100-C-SD SERIES

SERIES

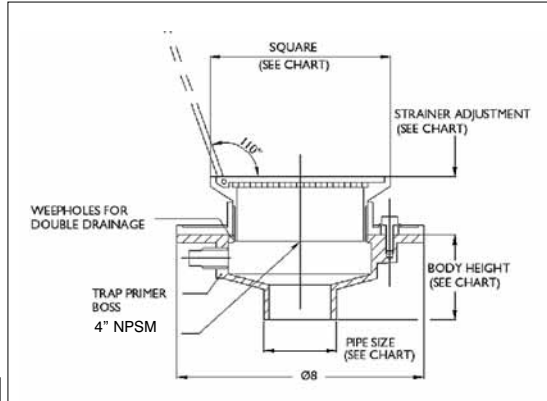
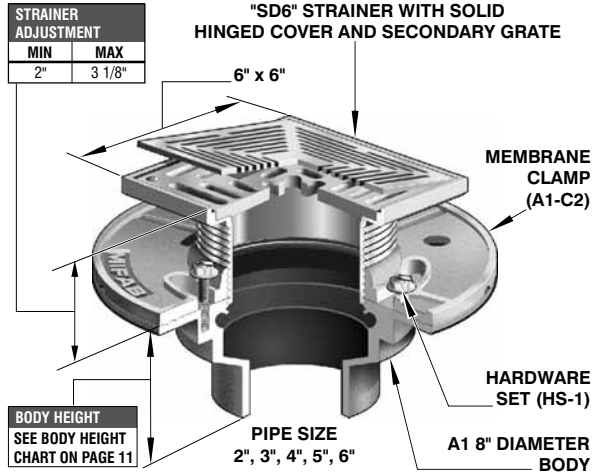

PARTS

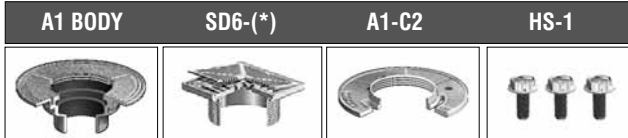

ANSI/ASME RATING		
STRAINER	FREE AREA	LOAD RATING
SD6-1,3	12 IN ²	5000 - 7499 lbs

(* Denotes strainer finish (-1 or -3)

FLOOR DRAIN WITH SQUARE SOLID HINGED COVER

MODEL NUMBER	WT. Lbs	STRAINER SIZE	NICKEL BRONZE (-1) STAINLESS STEEL (-3)
F1102,3,4-C-SD6	12.50	6" x 6"	\$638.00

WHEN NO MEMBRANE CLAMP IS REQUIRED, DELETE SUFFIX (-C) AND DEDUCT \$43.00

F1100-C-SD, F1100-C-SHG, F1100-C-T AND F1100-C-VD SERIES OPTIONAL VARIATIONS:

SUFFIX	DESCRIPTION	LIST PRICE	SUFFIX	DESCRIPTION	LIST PRICE
-5	Sediment bucket (A1-PB)	\$ 56.00	-21	Secondary flat strainer (FD-9600 Series)	\$ 31.00
-6	Security screws (TR25 torx and pin)	\$ 28.00	-28	Stainless Steel Body (Type 304) (2", 3", 4" No Hub)	P.O.A.
-7	Trap seal primer tapping	Standard.	-30	PVC Socket Connection Body (2", 3" or 4")	No Add
-8	Backwater valve (BV1250 Series) (2", 3", 4")	\$ 195.00	-31	ABS Socket Connection Body (2", 3" or 4")	No Add
-10	Decorative polished top (10 piece Min. order)	\$ 87.00	-34	Closure plug (C1440 Series)	\$ 187.00
-11	Acid resistant epoxy coated body (Min. order 25 pcs. or P.O.A)	\$ 133.00	-40	Underdeck clamp (A1-C3)	\$ 77.00
-13	Galvanized body (Min. order 25 pcs. or P.O.A)	\$ 101.00	-41	Sump receiver (A1-BP)	\$ 132.00
-15	Extension (DD-50)	\$ 71.00			

PVC/ABS Socket bodies available for 2", 3" or 4" connection sizes

F1100-C-SHG FLOOR DRAIN WITH SQUARE ADJUSTABLE HINGED STRAINER

F1100-C-SHG SERIES

SERIES

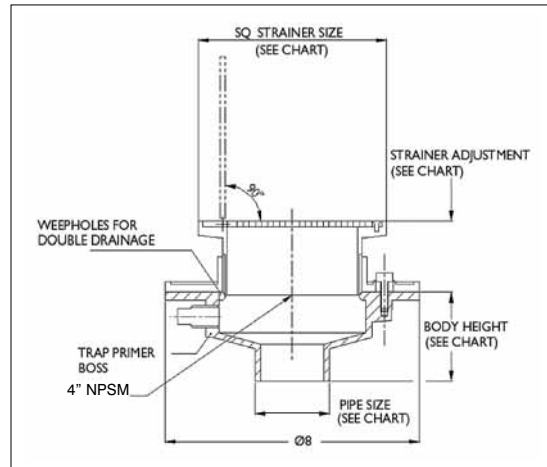
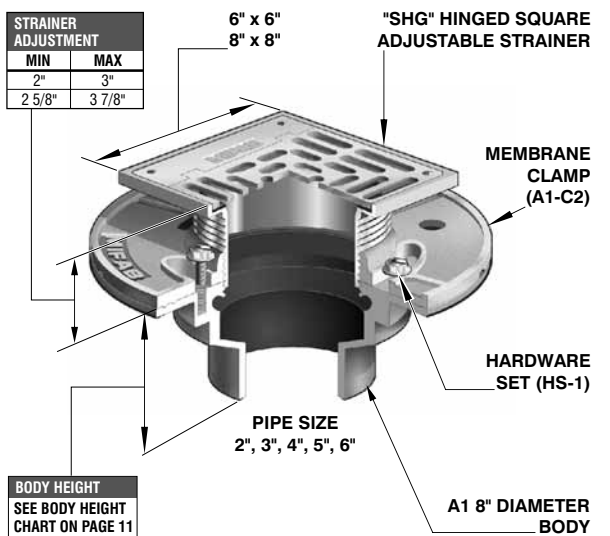

PARTS

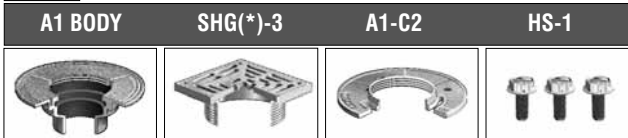

ANSI/ASME RATING		
STRAINER	FREE AREA	LOAD RATING
6" x 6"	9 IN ²	5000 - 7499 lbs
8" x 8"	20 IN ²	5000 - 7499 lbs

(* Denotes strainer size (6" x 6" or 8" x 8")

FLOOR DRAIN WITH SQUARE ADJUSTABLE HINGED STRAINER

MODEL NUMBER	WT. Lbs	STRAINER SIZE	LIST PRICE STAINLESS STEEL (-3)
F1102,3,4-C-SHG6-3	12.50	6" x 6"	\$438.00
F1102,3,4-C-SHG8-3	13.50	8" x 8"	\$844.00

WHEN NO MEMBRANE CLAMP IS REQUIRED, DELETE SUFFIX (-C) AND DEDUCT \$43.00

Design and dimensions are subject to modification. Prices do not include applicable taxes.

Visit www.mifab.com for the most recent product information.

MIFAB, Inc., 1321 West 119th Street, Chicago, Illinois 60643-5109, USA

Toll Free 1-800-465-2736, Fax 773-341-3049

All sales subject to MIFAB's Terms and Warranties. Please refer to inside front cover.