

## F1170-C FLOOR DRAIN WITH MULTI INLETS, ROUND STRAINER AND INTEGRAL TRAP F1170-C SERIES

SERIES

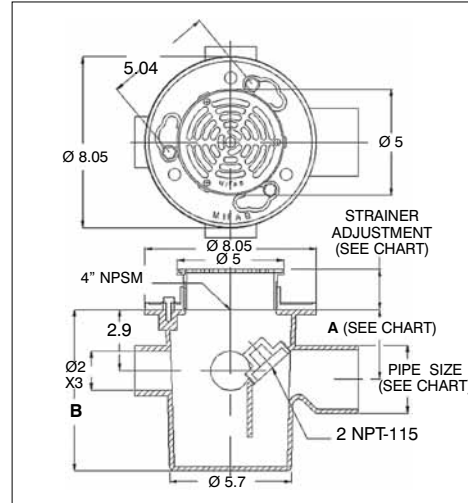
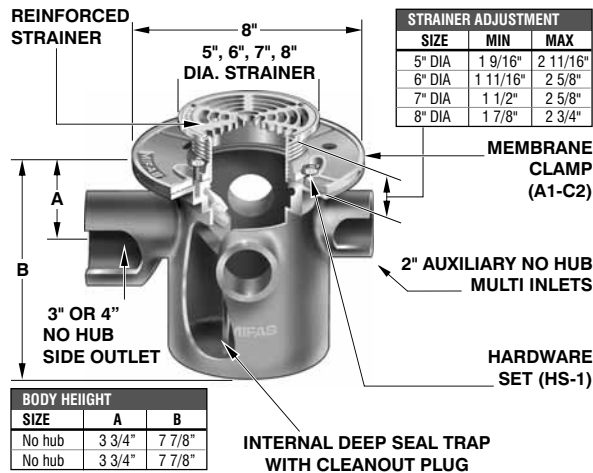

(\* Denotes strainer size (5, 6, 7 or 8)  
(\*\*) Denotes strainer finish (-1 or -3)

ANSI/ASME RATING	
FREE AREA	LOAD RATING
SEE F1100-C CHART ON PG. 11 FOR RATINGS	

### FLOOR DRAIN WITH MULTI INLETS, ROUND STRAINER AND INTEGRAL TRAP

MODEL NUMBER	WT. Lbs	OUTLET SIZE	STRAINER SIZE	LIST PRICE: NICKEL BRONZE (-1) STAINLESS STEEL (-3)
F1172,3,4-C-5	21.00	2", 3", 4"	5" DIA	\$582.00
F1172,3,4-C-6	21.50	2", 3", 4"	6" DIA	\$634.00
F1172,3,4-C-7	22.00	2", 3", 4"	7" DIA	\$683.00
F1172,3,4-C-8	23.00	2", 3", 4"	8" DIA	\$773.00

WHEN NO MEMBRANE CLAMP IS REQUIRED, DELETE SUFFIX (-C) AND DEDUCT \$43.00

### F1160 AND F1170 SERIES OPTIONAL VARIATIONS:

SUFFIX	DESCRIPTION	LIST PRICE	SUFFIX	DESCRIPTION	LIST PRICE
-5	Sediment bucket (A1-PB)	\$ 56.00	-44	2" no hub side inlet (specify location)	\$ 99.00
-6	Security screws (TR25 Torx & pin)	\$ 28.00	-F4-(1,3)	4" NB or SS round funnel	\$218.00
-7	Trap seal primer tapping	P.O.A.	-F4-50	4" cast iron round funnel	\$ 91.00
-8	Backwater valve (BV1250 Series)	\$195.00	-F6-(1,3)	6" NB or SS round funnel	\$325.00
-10	Decorative polished top (10 piece Min. order)	\$ 87.00	-F6-50	6" cast iron round funnel	\$147.00
-11	Acid resistant epoxy coating (Min. order 25 pcs. or P.O.A.)	\$192.00	-G-(1,3)	4" x 9" NB or SS oval funnel	\$454.00
-13	Galvanized body (Min. order 25 pcs. or P.O.A.)	\$192.00	-G-50	4" x 9" C.I. oval funnel	\$218.00
-15	Extension (DD-50)	\$ 71.00	-J-(1,3)	3" x 1" NB or SS oval funnel	P.O.A.
-34	Closure plug (C1440 Series)	\$187.00	-J-50	3" x 1" cast iron oval funnel	P.O.A.
			-Z	Extended wide elastomeric flange (13" dia. x 1/8 thick)	P.O.A.

## F1170-C-SD FLOOR DRAIN W/MULTI INLETS, SQUARE SOLID HINGED COVER & INTEGRAL TRAP F1170-C-SD SERIES

SERIES

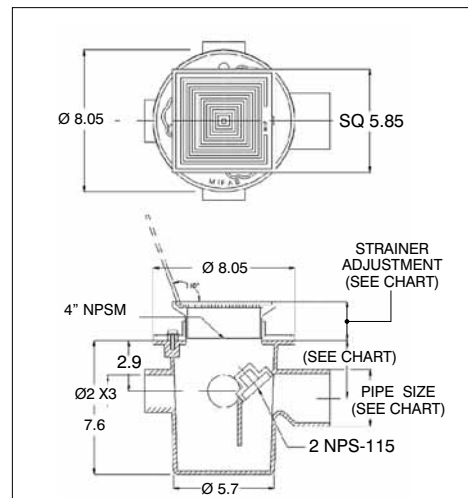
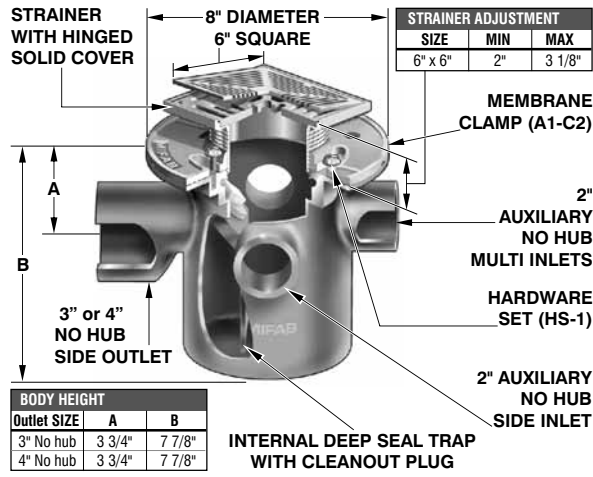

(\* Denotes strainer finish (-1 or -3)

ANSI/ASME RATING	
FREE AREA	LOAD RATING
12.0 IN <sup>2</sup>	5,000-7,499 Lbs

### FLOOR DRAIN WITH MULTI INLETS, SQUARE STRAINER AND INTEGRAL TRAP

MODEL NUMBER	WT. Lbs	OUTLET SIZE	STRAINER SIZE	LIST PRICE: NICKEL BRONZE (-1) STAINLESS STEEL (-3)
F1172,3,4-C-SD6	25.50	2", 3", 4"	6" x 6"	\$971.00

WHEN NO MEMBRANE CLAMP IS REQUIRED, DELETE SUFFIX (-C) AND DEDUCT \$43.00

Design and dimensions are subject to modification. Prices do not include applicable taxes. Visit [www.mifab.com](http://www.mifab.com) for the most recent product information.

MIFAB, Inc., 1321 West 119th Street, Chicago, Illinois 60643-5109, USA

Toll Free 1-800-465-2736, Fax 773-341-3049

All sales subject to MIFAB's Terms and Warranties. Please refer to inside front cover.