

F1100-C-RS SERIES FLOOR DRAIN WITH RECTANGULAR STRAINER

F1100-C-RS SERIES

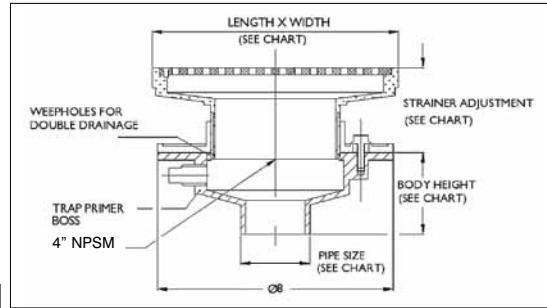

PARTS

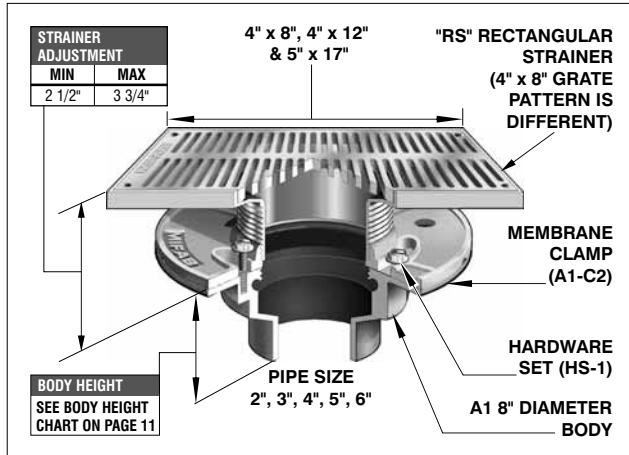
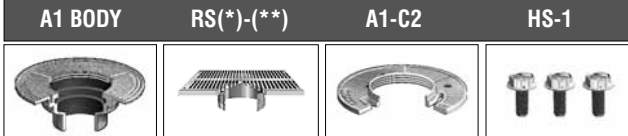

(*) Denotes strainer size (4" x 8", 4" x 12", or 5" x 17") (**) Denotes strainer finish (-1 or -3)

FLOOR DRAIN WITH RECTANGULAR STRAINER

MODEL NUMBER	WT. Lbs	STRAINER SIZE	LIST PRICE: NICKEL BRONZE (-1) STAINLESS STEEL (-3)
F1102,3,4-C-RS48	11.50	4" x 8"	\$544.00
F1102,3,4-C-RS412	12.00	4" x 12"	\$659.00
F1102,3,4-C-RS517-3	15.00	5" x 17"	\$786.00

WHEN NO MEMBRANE CLAMP IS REQUIRED, DELETE SUFFIX (-C) AND DEDUCT \$43.00

ANSI/ASME RATING

STRAINER	FREE AREA	LOAD RATING
RS48-1*	11.0 IN ²	UP TO 2000 lbs
RS412-1*	15.0 IN ²	UP TO 2000 lbs
RS517-3	20.0 IN ²	5,000 TO 7,499 lbs

*STAINLESS (-3) FOR ABOVE

F1100-C-K, F1100-C-N, F1100-C-RS AND F1100-C-S SERIES OPTIONAL VARIATIONS CONT. FROM PAGE 16

CONTINUE

SUFFIX	DESCRIPTION	LIST PRICE	SUFFIX	DESCRIPTION	LIST PRICE
-49	Chrome plated strainer assembly (-add to 1 only)	\$ 15.00	-J-(1,3)	3" x 1" NB or SS oval funnel	P.O.A.
-90	Threaded side outlet (2", 3")	\$ 112.00	-J-50	3" x 1" cast iron oval funnel	P.O.A.
	4" threaded side outlet	\$ 159.00	P	Push on outlet (2", 3" or 4")	No Add
-95	Client logo (10 piece min. order)	P.O.A.	T	Threaded outlet (2", 3" or 4")	\$ 40.00
-C	Membrane clamp (A1-C2)	\$ 43.00	-Z	Extended wide elastomeric flange (13" dia. x 1/8" thick)	P.O.A.
-C1	Low rough-in membrane clamp (A1-C1)	\$ 43.00	X	Inside caulk outlet (2", 3" or 4")	No Add
-F4-(1,3)	4" NB or SS round funnel	\$ 218.00	5	5" no hub outlet	\$ 284.00
-F4-50	4" cast iron round funnel	\$ 91.00	5T	5" threaded outlet	\$ 284.00
-F6-(1,3)	6" NB or SS round funnel	\$ 325.00	5X	5" inside caulk outlet	\$ 284.00
-F6-50	6" cast iron round funnel	\$ 147.00	6	6" no hub outlet	\$ 284.00
-G-(1,3)	4" x 9" NB or SS oval funnel	\$ 454.00	6P	6" push on outlet*	\$ 284.00
-G-50	4" x 9" C.I. oval funnel	\$ 218.00			

* Specify POG-6 for C.I. pipe and POG-6-PVC for PVC pipe. 2", 3", 4" sizes use same gasket.

F1100-C-S SERIES SQUARE FLOOR DRAIN

F1100-C-S SERIES

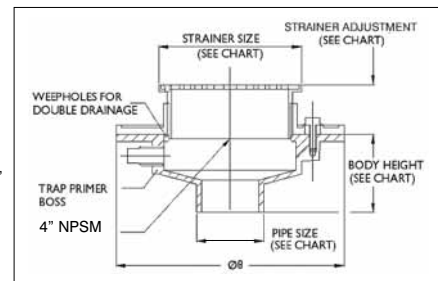
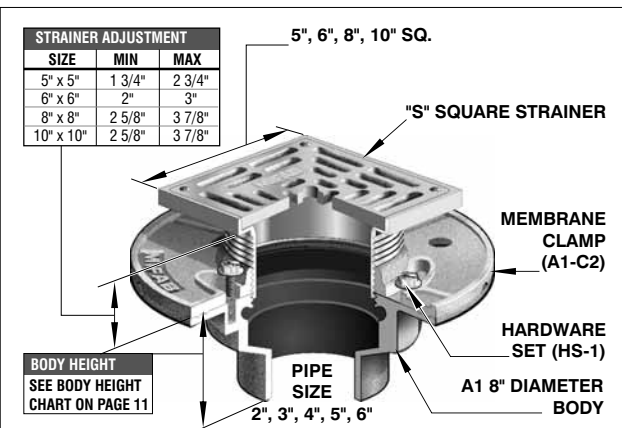

(*) Denotes strainer size (5" x 5", 6" x 6", 8" x 8", 10" x 10")

(**) Denotes strainer finish (-1, -3 or -4)

PARTS

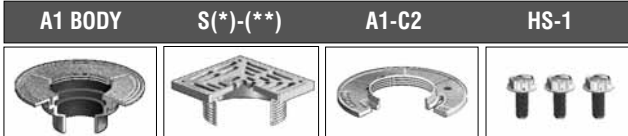

FLOOR DRAIN WITH SQUARE STRAINER

MODEL NUMBER	WT. Lbs	STRAINER SIZE	LIST PRICE: NICKEL BRONZE (-1) STAINLESS STEEL (-3)	LIST PRICE DUCTILE IRON (-4)
F1102,3,4-C-S5	9.00	5" x 5"	\$331.00	-
F1102,3,4-C-S6	11.50	6" x 6"	\$369.00	-
F1102,3,4-C-S8	13.00	8" x 8"	\$538.00	\$389.00
F1102,3,4-C-S10	14.50	10" x 10"	\$855.00	-

WHEN NO MEMBRANE CLAMP IS REQUIRED, DELETE SUFFIX (-C) AND DEDUCT \$43.00

ANSI/ASME RATING

STRAINER	FREE AREA	LOAD RATING
5" x 5" NB	9 IN ²	UP TO 2000 lbs
6" x 6" NB	12 IN ²	UP TO 2000 lbs
8" x 8" NB	26 IN ²	UP TO 2000 lbs
8" x 8" DI	26 IN ²	OVER 10,000 lbs
5" x 5" SS	9 IN ²	5000 TO 7499 lbs
6" x 6" SS	12 IN ²	5000 TO 7499 lbs
10" x 10" SS	28 IN ²	5000 TO 7499 lbs

All sales subject to MIFAB's Terms and Warranties. Please refer to inside front cover.

Design and dimensions are subject to modification. Prices do not include applicable taxes. Visit www.mifab.com for the most recent product information.

MIFAB, Inc., 1321 West 119th Street, Chicago, Illinois 60643-5109, USA

Toll Free 1-800-465-2736, Fax 773-341-3049

All sales subject to MIFAB's Terms and Warranties. Please refer to inside front cover.