

F1100-C-XS SERIES FLOOR DRAIN WITH HEAVY DUTY SQUARE STRAINER

F1100-C-XS SERIES

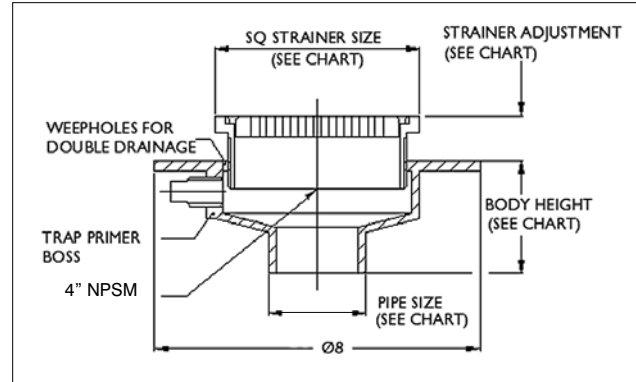

ANSI/ASME RATING		LOAD RATING		
STRAINER	FREE AREA	NICKEL BRONZE	STAINLESS STEEL	DUCTILE IRON
5" x 5"	9 IN ²	5000-7499 lbs	5000-7499 lbs	OVER 10,000 lbs
6" x 6"	12 IN ²	5000-7499 lbs	5000-7499 lbs	-
8" x 8"	26 IN ²	5000-7499 lbs	5000-7499 lbs	OVER 10,000 lbs
10" x 10"	28 IN ²	-	5000-7499 lbs	-

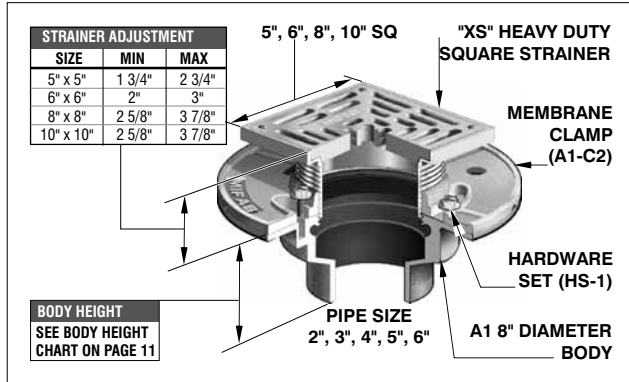
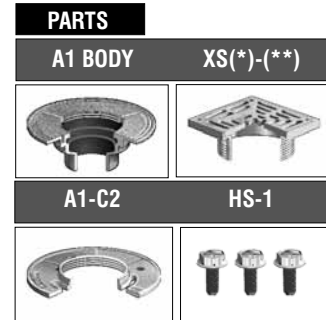

FLOOR DRAIN WITH HEAVY DUTY SQUARE STRAINER				
MODEL NUMBER	WT. Lbs	STRAINER SIZE	LIST PRICE: NICKEL BRONZE (-1) STAINLESS STEEL (-3)	LIST PRICE DUCTILE IRON (-4)
F1102,3,4-C-XS5	9.50	5" x 5"	\$ 388.00	-
F1102,3,4-C-XS6	12.00	6" x 6"	\$ 455.00	-
F1102,3,4-C-XS8	13.50	8" x 8"	\$ 640.00	\$389.00
F1102,3,4-C-XS10	14.50	10" x 10"	\$1133.00	-

(*) Denotes strainer size (5" x 5", 6" x 6", 8" x 8" or 10" x 10")
 (**) Denotes strainer finish (-1, -3, or -4)

WHEN NO MEMBRANE CLAMP IS REQUIRED, DELETE SUFFIX (-C) AND DEDUCT \$43.00

F1100-C-W(D), F1100-C-X, F1100-C-XS AND F1100-C-Z SERIES OPTIONAL VARIATIONS CONTINUED FROM PAGE 20. CONTINUE

SUFFIX	DESCRIPTION	LIST PRICE	SUFFIX	DESCRIPTION	LIST PRICE
-49	Chrome plated strainer assembly (-add to 1 only)	\$ 15.00	-J-(1,3)	3" x 1" NB or SS oval funnel	P.O.A.
-90	Threaded side outlet (2", 3")	\$ 112.00	-J-50	3" x 1" cast iron oval funnel	P.O.A.
	4" threaded side outlet	\$ 159.00	P	Push on outlet (2", 3" or 4")	No Add
-95	Client logo (10 piece Min. order)	P.O.A.	T	Threaded outlet (2", 3" or 4")	\$ 40.00
-C	Membrane clamp (A1-C2)	\$ 43.00	-Z	Extended wide elastomeric flange (13" dia. x 1/8 thick)	P.O.A.
-C1	Low rough-in membrane clamp (A1-C1)	\$ 43.00	X	Inside caulk outlet (2", 3" or 4")	No Add
-F4-(1,3)	4" NB or SS round funnel	\$ 218.00	5	5" no hub outlet	\$ 284.00
-F4-50	4" cast iron round funnel	\$ 91.00	5T	5" threaded outlet	\$ 284.00
-F6-(1,3)	6" NB or SS round funnel	\$ 325.00	5X	5" inside caulk outlet	\$ 284.00
-F6-50	6" cast iron round funnel	\$ 147.00	6	6" no hub outlet	\$ 284.00
-G-(1,3)	4" x 9" NB or SS oval funnel	\$ 454.00	6P	6" push on outlet*	\$ 284.00
-G-50	4" x 9" C.I. oval funnel	\$ 218.00			

* Specify POG-6 for C.I. pipe and POG-6-PVC for PVC pipe. 2", 3", 4" sizes use same gasket.

F1100-C-Z SERIES FLOOR DRAIN WITH ELASTOMERIC FLANGE

F1100-C-Z SERIES

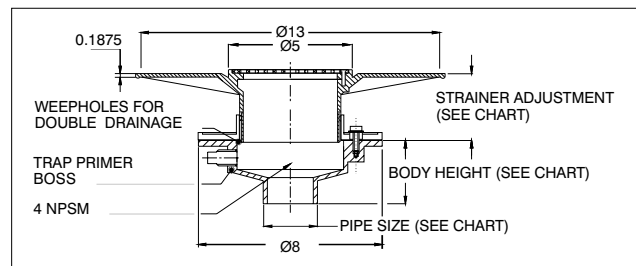
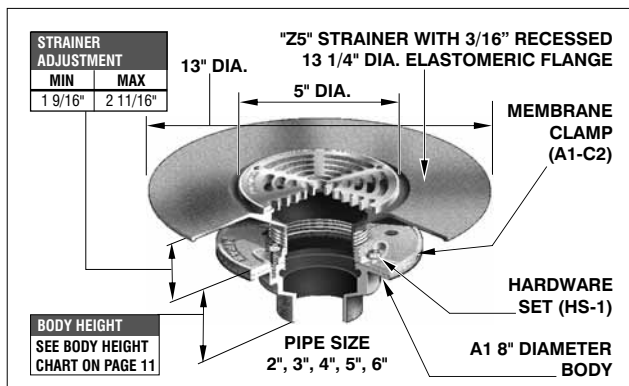

ANSI/ASME RATING		
STRAINER	FREE AREA	LOAD RATING
Z5-1	8 IN ²	UP TO 2000 lbs
Z5-3	8 IN ²	5000 - 7499 lbs

(*) Denotes strainer finish (-1 or -3)

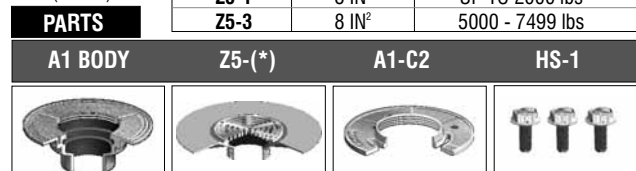

FLOOR DRAIN WITH ROUND STRAINER AND SOLID HINGED COVER			
MODEL NUMBER	WT. Lbs	STRAINER SIZE	LIST PRICE: NICKEL BRONZE (-1) STAINLESS STEEL (-3)
F1102,3,4-C-Z5	9.50	5" DIA	\$718.00

WHEN NO MEMBRANE CLAMP IS REQUIRED, DELETE SUFFIX (-C) AND DEDUCT \$43.00

Design and dimensions are subject to modification. Prices do not include applicable taxes.

Visit www.mifab.com for the most recent product information.

MIFAB, Inc., 1321 West 119th Street, Chicago, Illinois 60643-5109, USA

Toll Free 1-800-465-2736, Fax 773-341-3049

All sales subject to MIFAB's Terms and Warranties. Please refer to inside front cover.