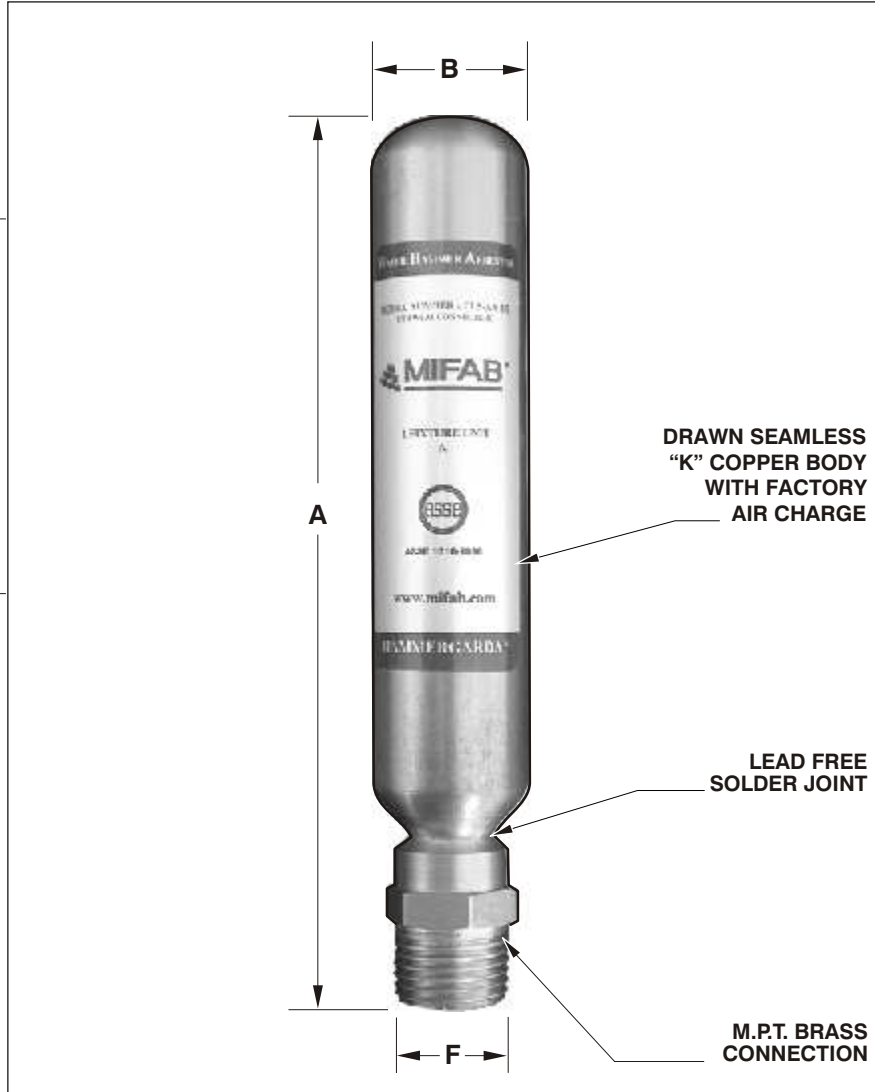

Specification: MIFAB® CL Series (specify size) piston operated water hammer arrestor with hard drawn seamless “K” copper body, RYTON PPS piston with double o-rings (Parco # 5778-80) and CDA 360 brass M.P.T. connection. Certified to the A.S.S.E. 1010-1996 and ANSI A112.26.1M Standards. Engineered to limit the system surge pressure up to 1,500 P.S.I.G.

Functions: Used in commercial, institutional and residential applications on water supply lines to reduce water hammer caused by the quick opening and closing of valves within the piping system. To be installed as close as possible to quick closing valves. The resulting hydraulic shock waves can lead to broken pipes and affect valves in appliances if not reduced with the use of a water hammer arrestor. An access door is not required to provide access to MIFAB’s water hammer arrestors.

MIFAB® HAMMERGARD® Series Features

- **SEAMLESS COPPER BODY.** Hard drawn seamless “K” copper body ensures maximum integrity and guarantees free movement of the piston for maximum performance
- **RYTON PPS piston.** Assembled with two Parco # 5778-80 o-rings and lubricated with Dow Corning # 111 FDA approved silicone compound. Ribbed piston design reduces secondary shock and flared piston skirt prevents hard particles suspended in the water supply from contacting the o-rings to provide increased product life and performance.
- **LARGE AIR CHAMBER VOLUME.** Provides better dampening for superior water hammer arrestor performance.
- **TEMPERATURE RANGE.** Maximum working temperature is 250F
- **OPERATING PRESSURE.** Up to 350 P.S.I.G. for effective and safe operation.
- **Patent # 6,539,976**

 Plumbing and Drainage
Mechanical Section

MODEL NO.	SIZE TYPE	FIXTURE UNIT CAPACITY	A (LENGTH)	B (DIAMETER)	F M.P.T. CONN.
CL-AA	AA	1	4 3/4"	7/8"	1/2"
CL-A	A	1-11	6"	1 1/8"	1/2"
CL-B	B	12-30	7 1/2"	1 1/8"	3/4"
CL-C	C	31-60	9"	1 3/8"	1"
CL-D	D	61-113	10 1/2"	1 5/8"	1 1/4"
CL-E	E	114-154	11 1/4"	2 1/8"	1 1/2"
CL-F	F	155-330	13"	2 5/8"	2"

Job Name: _____	Page No: _____
Section No: _____	Contractor: _____
Schedule No: _____	Purchase Order No: _____

Specification: MIFAB® CLS Series (specify size) piston operated water hammer arrestor with hard drawn seamless “K” copper body, RYTON PPS piston with double o-rings (Parco # 5778-80) and copper SWT connection. Certified to the A.S.S.E. 1010-1996 and ANSI A112.26.1M Standards. Engineered to limit the system surge pressure up to 1500 P.S.I.G.

Functions: Used in commercial, institutional and residential applications on water supply lines to reduce water hammer caused by the quick opening and closing of valves within the piping system. To be installed as close as possible to quick closing valves. The resulting hydraulic shock waves can lead to broken pipes and affect valves in appliances if not reduced with the use of a water hammer arrestor. An access door is not required to provide access to MIFAB’s water hammer arrestors.

MIFAB® HAMMERGARD® Series Features

- **SEAMLESS COPPER BODY.**
Hard drawn seamless “K” copper body ensures maximum integrity and guarantees free movement of the piston for maximum performance.
- **RYTON PPS piston.** Assembled with two Parco # 5778-80 o-rings and lubricated with Dow Corning # 111 FDA approved silicone compound. Ribbed piston design reduces secondary shock and flared piston skirt prevents hard particles suspended in the water supply from contacting the o-rings to provide increased product life and performance.
- **LARGE AIR CHAMBER VOLUME.**
Provides better dampening for superior water hammer arrestor performance.
- **TEMPERATURE RANGE.** Maximum working temperature is 250°F.
- **OPERATING PRESSURE.** Up to 350 P.S.I.G. for effective and safe operation.
- **Patent # 6,539,976**

Plumbing and Drainage
Mechanical Section

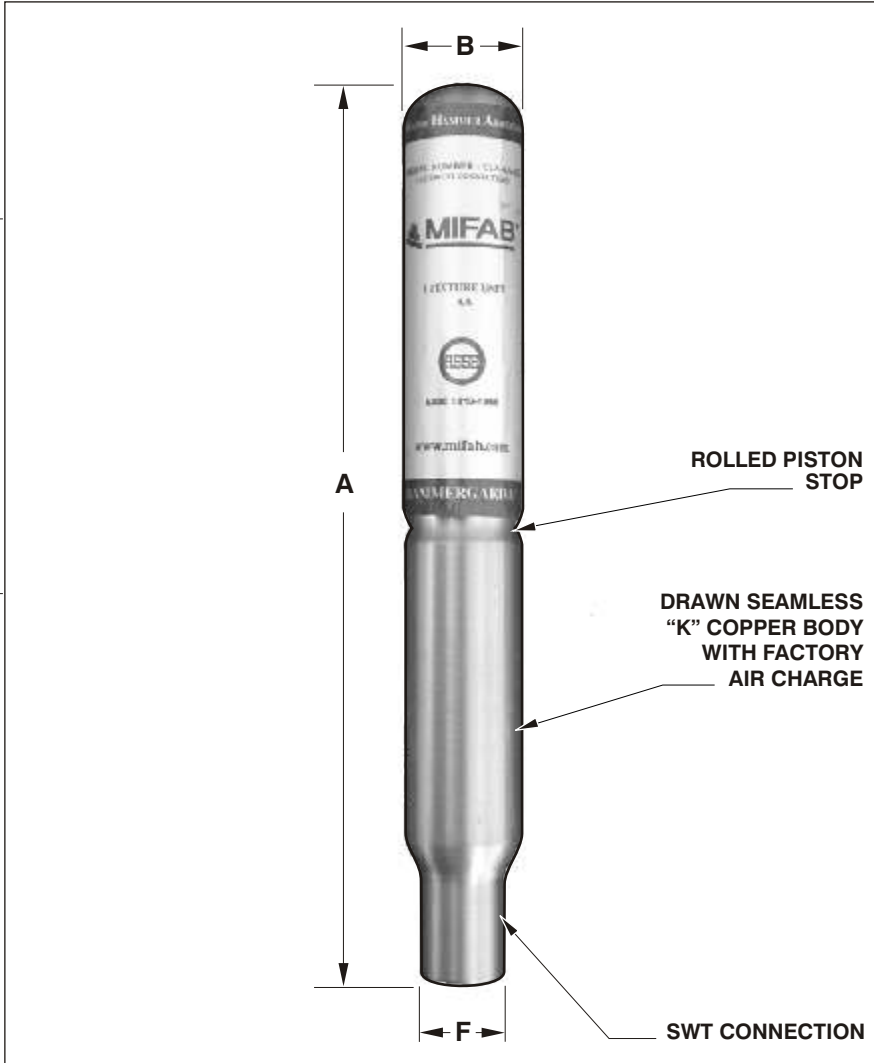

MODEL NO.	SIZE TYPE	FIXTURE UNIT CAPACITY	A (LENGTH)	B (DIAMETER)	F SWT CONN.
CLS-AA-1/2	AA	1	6 1/2"	7/8"	1/2"
CLS-AA-3/4	AA	1	6 1/2"	7/8"	3/4"
CLS-A	A	1-11	8 1/4"	1 1/8"	1/2"
CLS-B	B	12-30	10"	1 1/8"	3/4"
CLS-C	C	31-60	12 1/2"	1 3/8"	1"
CLS-D	D	61-113	11"	2 1/8"	1"
CLS-E	E	114-154	13 1/2"	2 1/8"	1"
CLS-F	F	155-330	16"	2 1/8"	1"

Job Name: _____	Page No: _____
Section No: _____	Contractor: _____
Schedule No: _____	Purchase Order No: _____



CL-COMP

PISTON OPERATED WATER HAMMER ARRESTOR WITH COMPRESSION CONNECTIONS

Specification: MIFAB® CL-COMP Series (specify compression connection size) piston operated water hammer arrestor with hard drawn seamless “K” copper body, RYTON PPS piston with double o-rings (Parco # 5778-80) and forged brass compression connections. Certified to the A.S.S.E. 1010-1996 and ANSI A112.26.1M Standards. Engineered to limit the system surge pressure up to 1500 P.S.I.G.

Functions: Used in single fixture applications on water supply lines to reduce water hammer caused by the quick opening and closing of valves within the piping system. To be installed as close as possible to quick closing valves. The resulting hydraulic shock waves can lead to broken pipes and affect valves in appliances if not reduced with the use of a water hammer arrestor.

Plumbing and Drainage
Mechanical Section

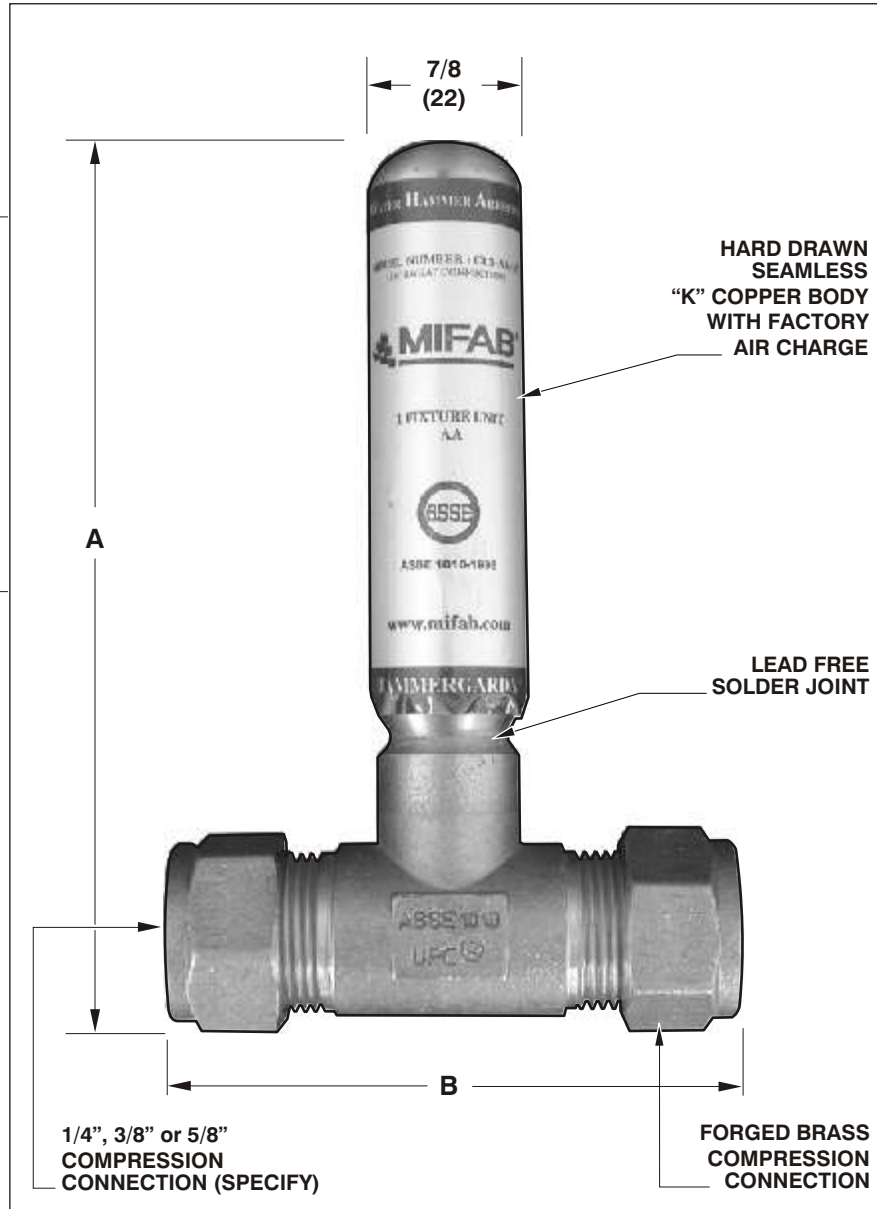

MIFAB® HAMMERGARD® Series Features and Benefits

- **SEAMLESS COPPER BODY.** Hard drawn seamless “K” copper body ensures maximum integrity and guarantees free movement of the piston for maximum performance.
- **RYTON PPS piston.** Assembled with two Parco # 5778-80 o-rings and lubricated with Dow Corning # 111 FDA approved silicone compound. Ribbed piston design reduces secondary shock and flared piston skirt prevents hard particles suspended in the water supply from contacting the o-rings to provide increased product life and performance.
- **LARGE AIR CHAMBER VOLUME.** Provides better dampening for superior water hammer arrestor performance.
- **TEMPERATURE RANGE.** Maximum working temperature is 250°F
- **OPERATING PRESSURE.** Up to 350 P.S.I.G. for effective and safe operation.
- **Patent # 6,539,976**



(Dimension) Denotes Millimetres

MODEL NO.	SIZE TYPE	FIXTURE UNIT CAPACITY	A (LENGTH)	B (WIDTH)	F M.P.T. CONN.
CL-1/4 COMP	AA	1	4 3/4" (121)	2 3/8" (60)	1/4" (6)
CL-3/8 COMP	AA	1	4 7/8" (124)	2 3/4" (70)	3/8" (9)
CL-5/8 COMP	AA	1	4 7/8" (124)	3" (76)	5/8" (16)

Job Name: _____	Page No: _____
Section No: _____	Contractor: _____
Schedule No: _____	Purchase Order No: _____

MIFAB reserves the right to make changes in material and design without formal notice and obligation.

USA: 1-800-465-2736 www.mifab.com CAN: 1-800-387-3880

Specification: MIFAB® CL-LAUNDRY Series piston operated water hammer arrestor with hard drawn seamless “K” copper body, RYTON PPS piston with double o-rings (Parco # 5778-80) and 3/4” female hose coupling x 3/4” M.I.P. connections. Certified to the A.S.S.E. 1010-1996 and ANSI A112.26.1M Standards. Engineered to limit the system surge pressure up to 1500 P.S.I.G.

Functions: Used in single fixture applications on water supply lines to reduce water hammer caused by the quick opening and closing of valves within the piping system. Typically used with washing machines. Install as close as possible to the solenoid valve. The CL-LAUNDRY can be used with new and existing laundry equipment. To install, turn off the hot and cold water supply, disconnect the hoses from the valves, connect the CL-LAUNDRY to the valve via the female hose coupling connection and then reconnect the equipment hose to the M.I.P. inlet connection. Hose washers are provided to ensure a water tight seal. The resulting hydraulic shock waves can lead to broken pipes and affect valves in appliances if not reduced with the use of a water hammer arrestor.

Plumbing and Drainage
Mechanical Section

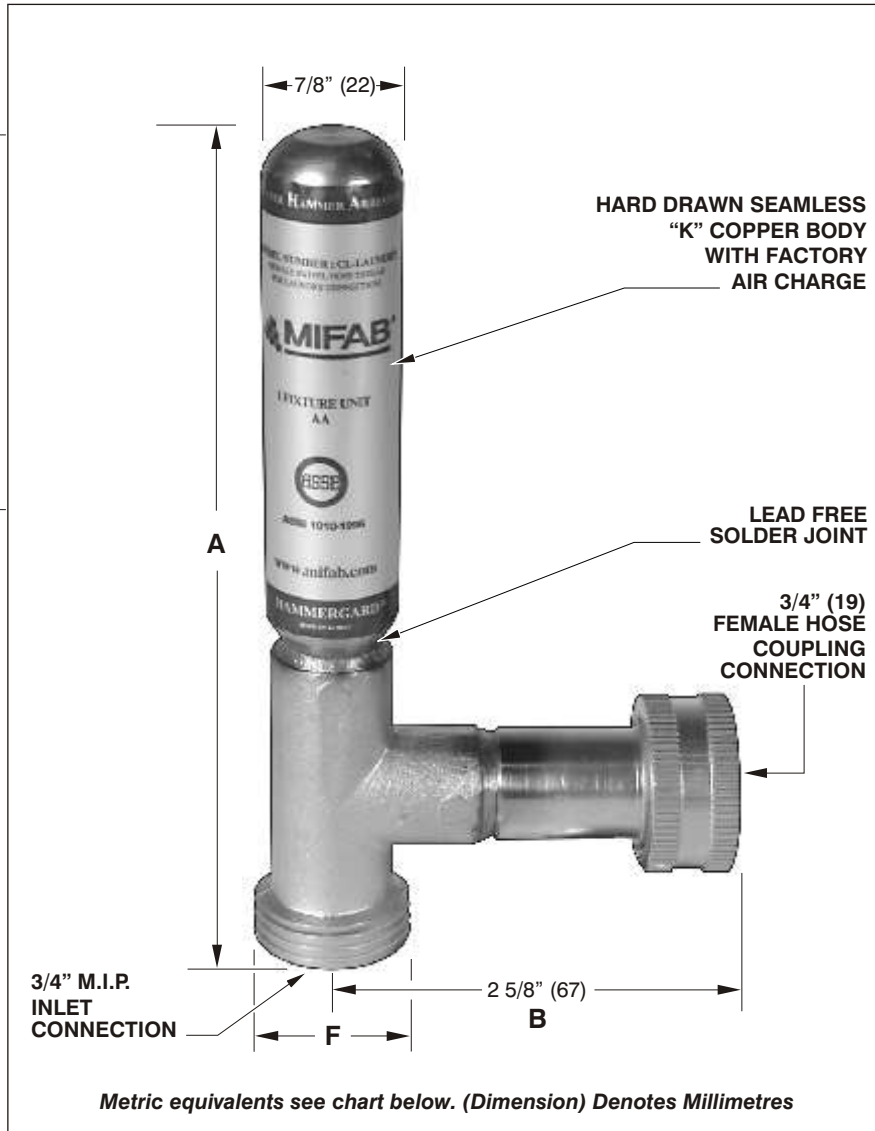

MIFAB® HAMMERCARD® Series Features

- **SEAMLESS COPPER BODY.** Hard drawn seamless “K” copper body ensures maximum integrity and guarantees free movement of the piston for maximum performance
- **RYTON PPS piston.** Assembled with two Parco # 5778-80 o-rings and lubricated with Dow Corning # 111 FDA approved silicone compound. Ribbed piston design reduces secondary shock and flared piston skirt prevents hard particles suspended in the water supply from contacting the o-rings to provide increased product life and performance.
- **LARGE AIR CHAMBER VOLUME.** Provides better dampening for superior water hammer arrestor performance.
- **TEMPERATURE RANGE.** Maximum working temperature is 250°F
- **OPERATING PRESSURE.** Up to 350 P.S.I.G. for effective and safe operation.
- **Patent # 6,539,976**



MODEL NO.	SIZE TYPE	FIXTURE UNIT CAPACITY	A HEIGHT	B CENTER LINE TO FEMALE HOSE COUPLING	F M.P.T. INLET CONNECTION
CL-LAUNDRY	AA	1	5 5/8" (143)	2 5/8" (67)	3/4" (19)

Job Name: _____ Page No: _____
 Section No: _____ Contractor: _____
 Schedule No: _____ Purchase Order No: _____

MIFAB reserves the right to make changes in material and design without formal notice and obligation.

USA: 1-800-465-2736 www.mifab.com CAN: 1-800-387-3880



M-500

PRESSURE DROP ACTIVATED TRAP SEAL PRIMER

Internet address: www.mifab.com

Toll Free: 1-800-465-2736

Canada Toll Free: 1-800-387-3880

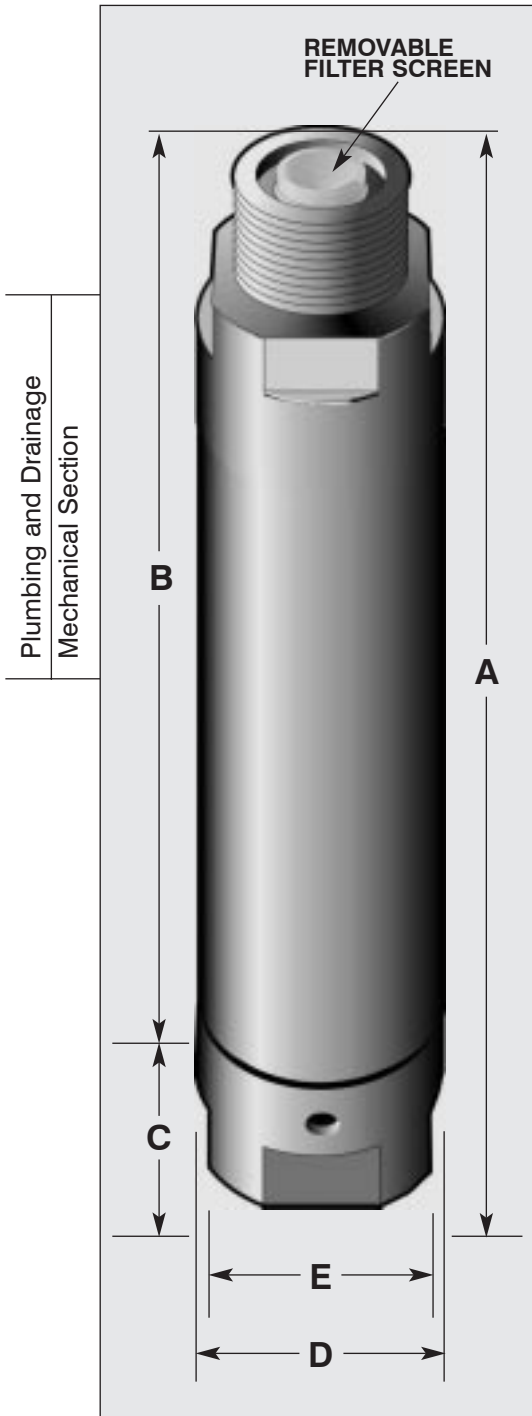

SPECIFICATION: MIFAB® model MR-500 pressure drop activated brass trap seal primer, with inlet opening of 1/2" (13) male N.P.T. and outlet opening of female 1/2" (13) N.P.T. Complete with four view holes and removable filter screen. Serves up to 6 floor drain traps and requires no adjustments and no air pre-charge.

SPECIFICATION: MIFAB® model M1-500 pressure drop activated brass trap seal primer, with inlet opening of 1/2" (13) male N.P.T. and outlet opening of female 1/2" (13) N.P.T. Complete with four view holes and removable filter screen. Serves up to 10 floor drain traps and requires no adjustments and no air pre-charge.

SPECIFICATION: MIFAB® model M2-500 pressure drop activated brass trap seal primer, with inlet opening of 1/2" (13) male N.P.T. and outlet opening of female 1/2" (13) N.P.T. Complete with four view holes and removable filter screen. Serves up to 3 floor drain traps and requires no adjustments and no air pre-charge.



MODEL NO.	A	B	C	D	E	NUMBER OF DRAINS SERVED
	IN	IN	IN	IN	IN	
MR-500	4 1/8" (105)	3 1/4" (82)	7/8" (22)	1 1/4" (32)	1 1/8" (29)	6
M1-500	4 1/8" (105)	3 1/4" (82)	7/8" (22)	1 1/4" (32)	1 1/8" (29)	10
M2-500	4 1/8" (105)	3 1/4" (82)	7/8" (22)	1 1/4" (32)	1 1/8" (29)	3

FUNCTION AND DESCRIPTION: MIFAB's M-500 Series of pressure activated trap seal primers (MR-500, M1-500 and M2-500) can be connected to any cold water line, and will be automatically activated when a valve or faucet, that is on the line, is opened. A pressure drop of three p.s.i. will activate all of the trap seal primers. MIFAB's M-500 Series of trap seal primers can be disassembled in the field. Their unique design permits filter replacement without affecting the performance of the primer. The "O" ring seals are tested for reliability at a temperature range of -40 degrees to 450 degrees F. The M-500 Series of trap seal primers do not require adjustment. The operating range for all of MIFAB's M-500 Series of trap seal primers is 20 to 125 p.s.i. All three models are listed with I.A.P.M.O. and C.S.A. and are tested and certified to the A.S.S.E. Standard 1018 and are so marked. U.S. Patent # 6,152,164.

(Dimension) Denotes Millimetres



INSTALLATION INSTRUCTIONS

FOR M-500 TRAP SEAL PRIMERS

Internet address: www.mifab.com

Toll Free: 1-800-465-2736

Canada Toll Free: 1-800-387-3880

INSTALLATION INSTRUCTIONS: An 1 1/8" open end wrench should be used to install the M-500 Series of trap seal primers to the line by using the flats on the top of the trap seal primer. Water lines must be flushed before installing MIFAB's M-500 Series of trap seal primers. The trap seal primers should be cycled at least six times to ensure optimum performance. Ensure that all flux and other debris is removed. Use only teflon tape around threads. Do not use pipe dope. Do not solder fittings directly onto the inlet or outlet of the primer. Failure to follow these instructions will negatively affect performance of the product. MIFAB's primers have a unique design which allows the primer to be taken apart and cleaned before re-assembly. Do this in the event of excess water discharge. Do not install the trap seal primers closer than forty feet apart when using the same potable water supply line. Trap seal primers should be mounted one foot above the finished floor for every twenty feet of floor drain trap make-up water line. For easy access to the trap seal primer, install a union connection above it. Install a line shut off valve upstream of the trap seal primer in order to shut off the water supply when performing maintenance on the trap seal primer.

INSPECTION INSTRUCTIONS: After installing and pre-cycling the trap seal primer, use any of the four holes to view water discharge from the orifice. A light can be placed opposite the observed view hole to improve clarity in this inspection.

MAINTENANCE INSTRUCTIONS: In order to replace the filter screen, remove the trap seal primer by using an open end wrench on the top set of flats. Grasp the top of the filter screen with fingers, squeeze and remove the filter. Insert the new filter screen by squeezing and pushing it firmly down into the top of the trap seal primer. Re-install the trap seal primer using the top set of flats. In regions that experience heavy residual deposits such as calcium in the water supply, MIFAB's M-500 Series of trap seal primers can be field refurbished by removing the bottom end of the primer, and replacing the cartridge.

Plumbing and Drainage
Mechanical Section

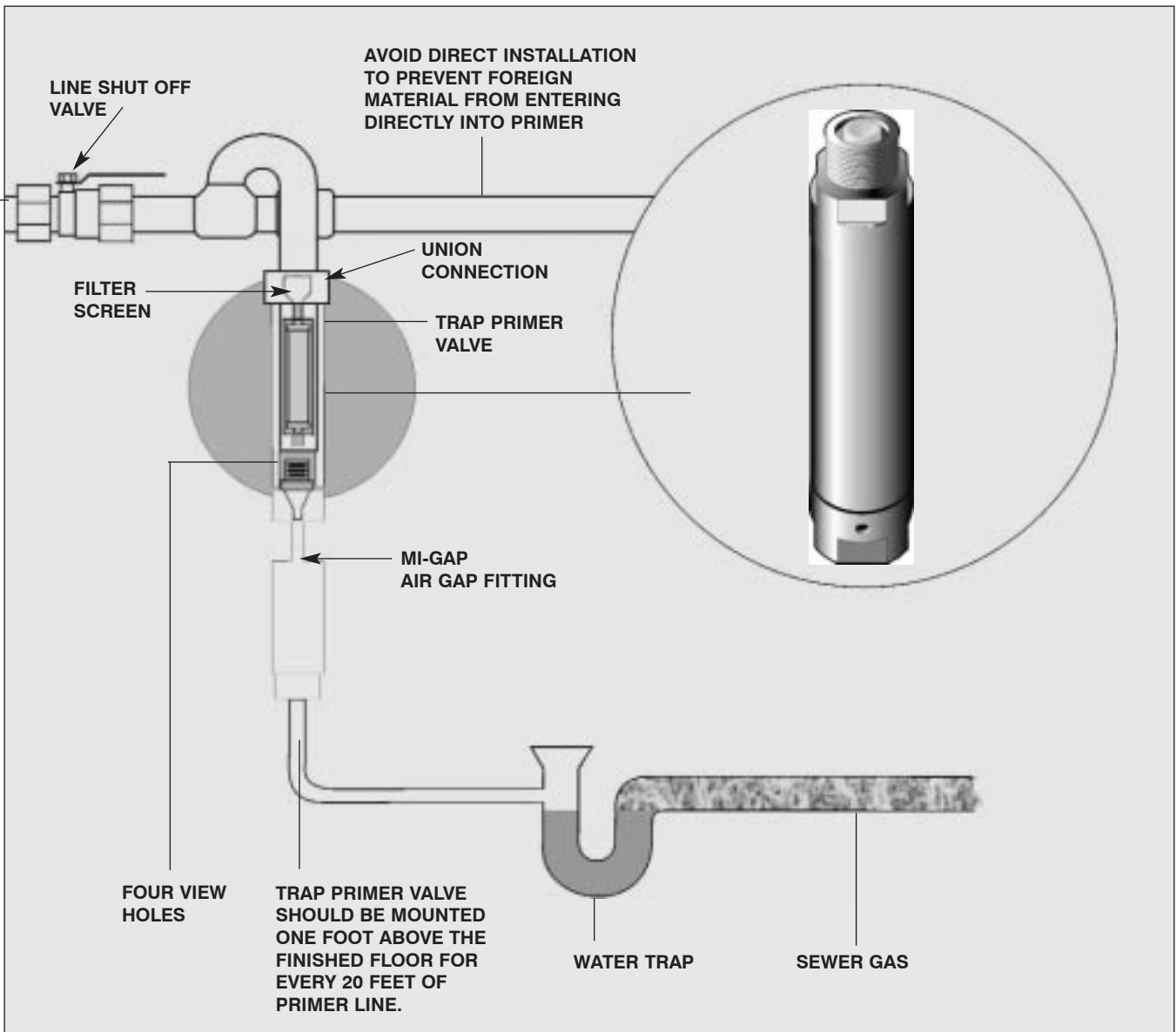

(Dimension) Denotes Millimetres



MI-100

ENCLOSED ELECTRONIC TRAP SEAL PRIMER SYSTEM

Specification: MIFAB® Series MI-100* (*specify 4 through to 32 outlet ports) enclosed electronic trap seal primer system with bronze body, 1/2" female NPT ball valve, electrical brass body 1/2" solenoid valve, 3/4" type "L" copper manifold with distribution units with compression connections for water distribution. Electrical components to include single point power connection at 120VAC or 24VDC, manual override switch, minimum 5 amp breaker, 24 hour timer with relay and adjustable delay. All components to be factory assembled and installed into a 16 gauge satin coated steel box for recessed (standard) or surface mounted (specify suffix -SM) installation. Electronic components are tested and certified to U.L. Standard # 73 and the entire assembly is tested and certified to the ASSE 1044 Standard.

Function: Used in areas that require frequent and automatic distribution of water into floor drain traps to maintain the water seal. This will prevent sewer gas from entering the area through the floor drains. A minimum of two ounces of water are supplied per opening at 20 PSIG once in every 24 hour period.

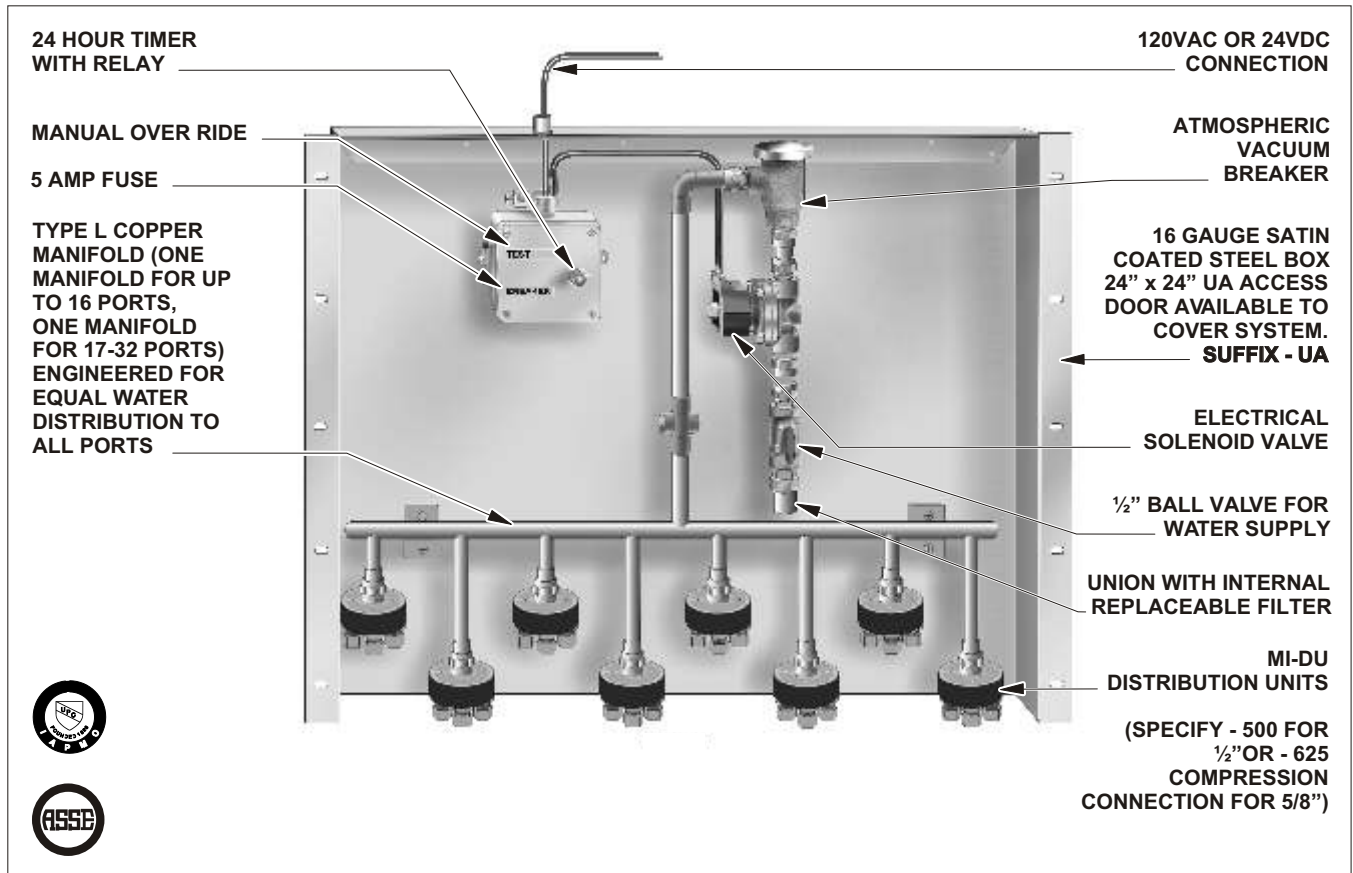

MODEL NUMBER	DESCRIPTION
MI-100-4	2- 4 opening ports with flush mounted box
MI-100-8	5- 8 opening ports with flush mounted box
MI-100-12	9-12 opening ports with flush mounted box
MI-100-16	13-16 opening ports with flush mounted box
MI-100-20	17-20 opening ports with flush mounted box
MI-100-24	21-24 opening ports with flush mounted box
MI-100-28	25-28 opening ports with flush mounted box
MI-100-32	29-32 opening ports with flush mounted box

OPTIONAL VARIATIONS:

- Surface Mounted Box
- 24" x 24" Access Door

SUFFIX

- SM
- UA

OPTIONAL VARIATIONS:

- 1/2" compression connection
- 5/8" compression connection

SUFFIX

- 500
- 625

Job Name _____ Page No: _____
 Section No: _____ Contractor _____
 Schedule No: _____ Purchase Order No: _____

MIFAB reserves the right to make changes in material and design without formal notice and obligation.



MI-200

ELECTRONIC TRAP SEAL PRIMER WITH AIR GAP

Specification: MIFAB® Series MI-200, electronic trap seal primer system with copper air gap, electrical brass body 1/2" solenoid valve and 24" wiring harness. Electrical components to include single point power connection at 115vAC or 24vDC. Electronic components are tested and certified to the U.L. Standard # 73 and the entire assembly is tested and certified to the ASSE 1044 Standard.

Function: The MI-200 is engineered to connect to the low-voltage building energy management system used to control the services in commercial, educational and institutional buildings. It can be located anywhere in the water supply. MIFAB's MI-DU Series of distribution units can be connected to the bottom of the MI-200 to serve more than one drain. The MI-200 is practical for infrequently used buildings such as convention centers and sports facilities. It is manufactured in accordance to the ANSI/ASME A112.1.2 air gap in plumbing systems Standard. The UA 12" x 12" access door is suggested for access to the MI-200 when installed into the wall.

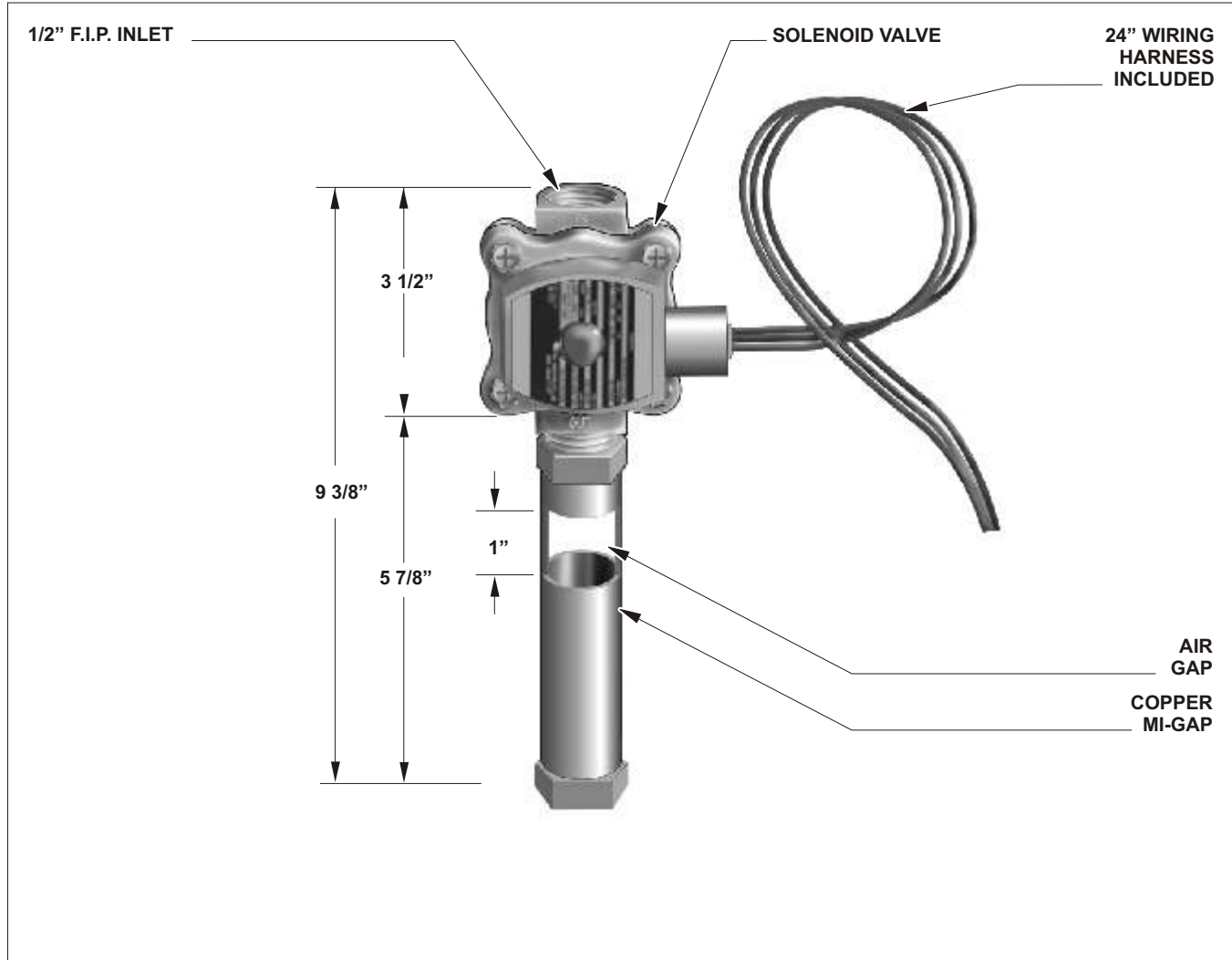

MODEL NUMBER	DESCRIPTION
MI-200-24v	24 volt DC
MI-200-115v	115 volt AC

- OPTIONAL VARIATIONS:**
- 12" x 12" Access Door
 - Four port distribution unit with 1/2" compression connections
- SUFFIX**
-UA1212 specify MI-DU-500
- Four port distribution unit with 5/8" compression connections specify MI-DU-625

Job Name _____	Page No: _____
Section No: _____	Contractor _____
Schedule No: _____	Purchase Order No: _____

MIFAB reserves the right to make changes in material and design without formal notice and obligation.



MI-300

ELECTRONIC TRAP SEAL PRIMER WITH AIR GAP, DISTRIBUTION UNIT AND CONTROL PANEL

Specification: MIFAB® Series MI-300, electronic trap seal primer system with copper air gap, electrical brass body 1/2" solenoid valve, 24" wiring harness and four port distribution unit (specify MI-DU-500 or MI-DU-625) with compression connections for water distribution. Electrical components to include single point power connection at 115vAC or 24vDC, manual override switch, minimum 5 amp breaker, 24 hour timer with relay and adjustable delay. Electronic components are tested and certified to the U.L. Standard # 73 and the entire assembly is tested and certified to the ASSE 1044 Standard.

Function: The MI-300 is practical for infrequently used buildings such as convention centers and sports facilities. It is engineered to connect to the low-voltage building energy management system used to control the services in commercial, educational and institutional buildings. The water discharge frequency can be adjusted to meet the building's needs. It can be located anywhere in the water supply. MIFAB's MI-DU Series of distribution unit is connected to the bottom of the MI-300 to serve up to four drains. Additional distribution units can be added to serve up to 13 drains. The MI-300 is manufactured in accordance to the ANSI/ASME A112.1.2 air gap in plumbing systems Standard. The UA 18" x 18" access door is suggested for access to the MI-300 when installed into the wall.

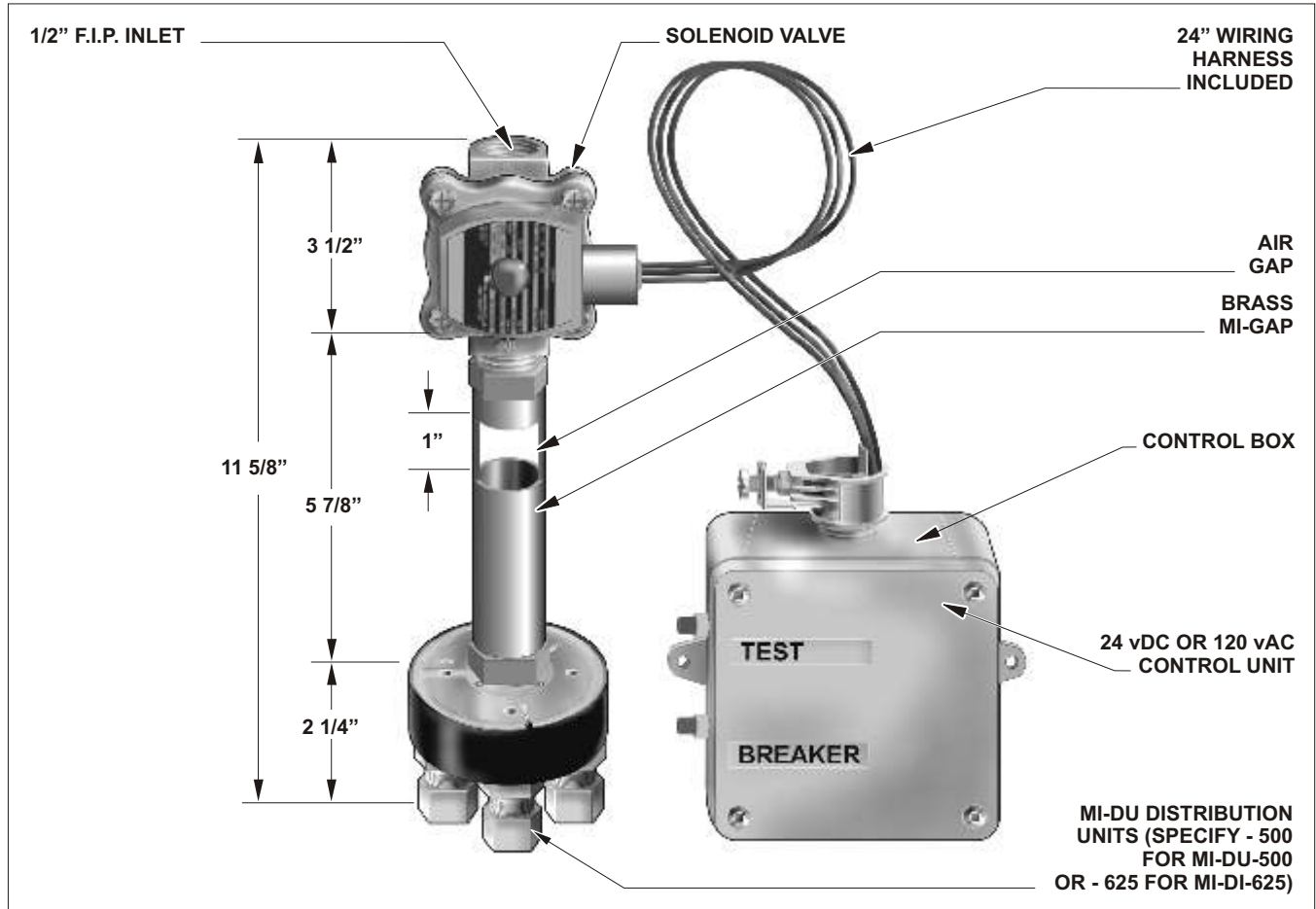

MODEL NUMBER	DESCRIPTION
MI-300-500-24v	24 volt DC electrical wiring with four port, 1/2" compression connection distribution unit.
MI-300-625-24v	24 volt DC electrical wiring with four port, 5/8" compression connection distribution unit.
MI-300-500-115v	115 volt DC electrical wiring with four port, 1/2" compression connection distribution unit.
MI-300-625-115v	115 volt DC electrical wiring with four port, 5/8" compression connection distribution unit.

OPTIONAL VARIATIONS:

- 18" x 18" Access Door
- Four port distribution unit with 1/2" compression connections

SUFFIX

- UA1818
- specify -500

SUFFIX

- Four port distribution unit with 5/8" compression connections
- specify -625

Job Name _____	Page No: _____
Section No: _____	Contractor _____
Schedule No: _____	Purchase Order No: _____

MIFAB reserves the right to make changes in material and design without formal notice and obligation.



MI-600

P-TRAP TRAP SEAL PRIMER CONNECTOR

Internet address: www.mifab.com

Toll Free: 1-800-465-2736

Canada Toll Free: 1-800-387-3880

SPECIFICATION: MIFAB Series MI-6___ ABS or PVC (specify) schedule #40 D.W.V. P-trap trap seal primer connector, with 2", 3" (75), or 4" (100) (specify) pipe connections, and a 1/2" (13) or 5/8" (16) (specify) brass compression fitting connection to attach to a trap seal primer water supply line. The MIFAB MI-600 Series of P-trap trap seal primer connectors meet the ASTM D-2661 and ASTM D-2665 Standards.

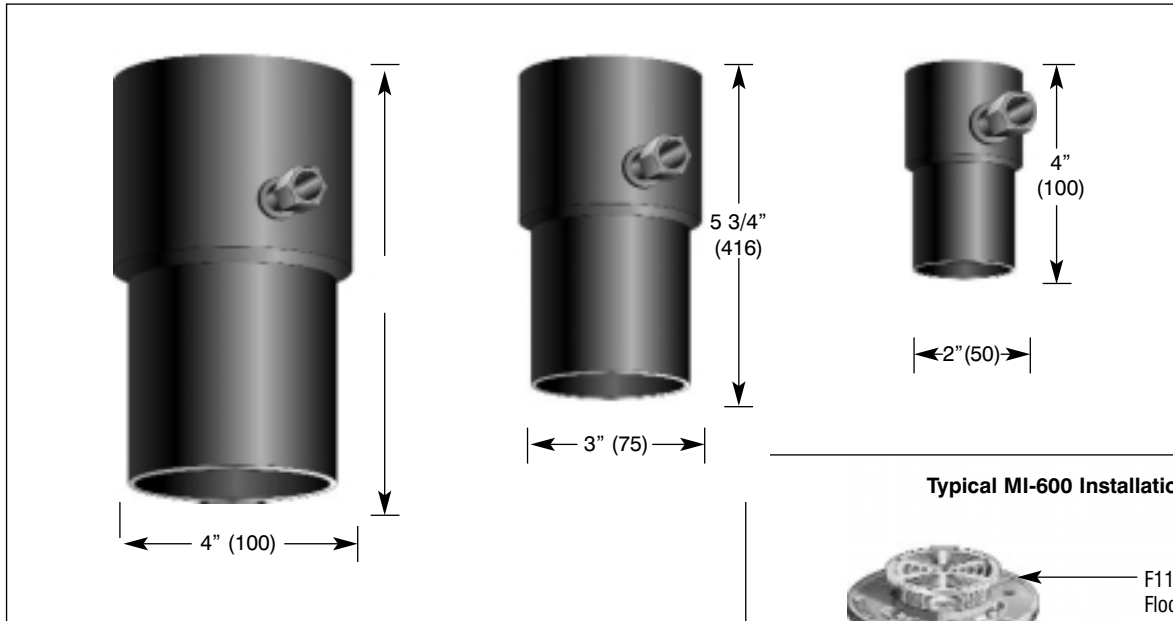

FEATURES:

- Can be rotated 360 degrees prior to cementing inside a standard p-trap in order to receive a water supply from any direction.
- Eliminates a no-hub tapped p-trap, 2 ABS no hub adaptors and 2 no hub couplings or PVC no-hub adaptors.
- No moving parts, simple installation and low cost
- Either a 1/2" (13) or 5/8" (16) brass compression fitting is supplied with each unit for the water supply attachment.

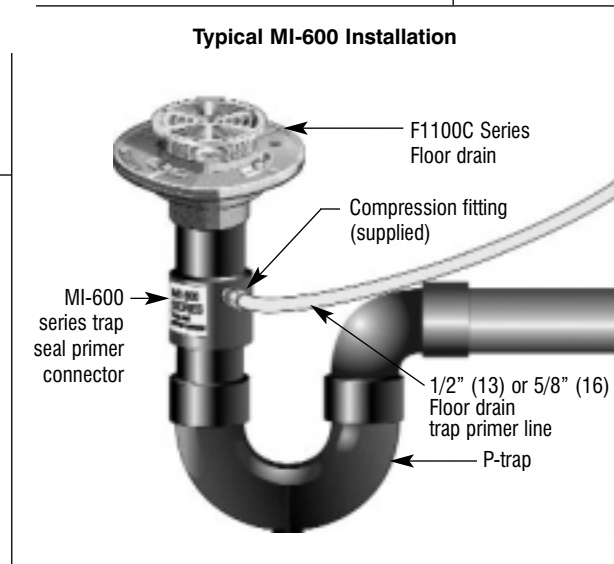

MODEL NO.	CONNECTION SIZE	COMPRESSION FITTING SIZE	MATERIAL TYPE	INDIVIDUAL WEIGHT (LBS.)	CARTON QUANTITY	CARTON WEIGHT (LBS.)
MI-602	2" (50)	1/2" (13)	ABS	.30	24	7.20
MI-603	3" (75)	1/2" (13)	ABS	.50	18	9.00
MI-604	4" (100)	1/2" (13)	ABS	.70	12	8.40
MI-612	2" (50)	5/8" (16)	ABS	.30	24	7.20
MI-613	3" (75)	5/8" (16)	ABS	.50	18	9.00
MI-614	4" (100)	5/8" (16)	ABS	.70	12	8.40
MI-622	2" (50)	1/2" (13)	PVC	.30	24	7.20
MI-623	3" (75)	1/2" (13)	PVC	.50	18	9.00
MI-624	4" (100)	1/2" (13)	PVC	.70	12	8.40
MI-632	2" (50)	5/8" (16)	PVC	.30	24	7.20
MI-633	3" (75)	5/8" (16)	PVC	.50	18	9.00
MI-634	4" (100)	5/8" (16)	PVC	.70	12	8.40

(Dimension) Denotes Millimetres



MI-700 & MI-701

TAILPIECE TRAP SEAL PRIMER

Internet address: www.mifab.com

Toll Free: 1-800-465-2736

Canada Toll Free: 1-800-387-3880

SPECIFICATION: MIFAB Series MI-____ (specify 700 for 1 1/4" (31) diameter or 701 for 1 1/2" (38) diameter), 17 gage chrome plated tubular brass tailpiece trap seal primer with 5/8" (15) compression fitting.

FUNCTION: MIFAB's MI-700 Series of tailpiece trap seal primers replace the standard flush valve connection to provide a fresh water discharge to replenish the floor drain trap seal. Three ounces of water will flow through the priming tube connection each time the flush valve operates.

INSTALLATION: MIFAB's MI-700 Series of tailpiece trap seal primers are engineered to prime one floor drain trap that is no further than twenty feet from the flush valve primer. A 1/2" (13) O.D. copper make-up water line connecting the tailpiece trap seal primer to the floor drain trap is recommended. It also serves lavs, sinks, and flush valves.

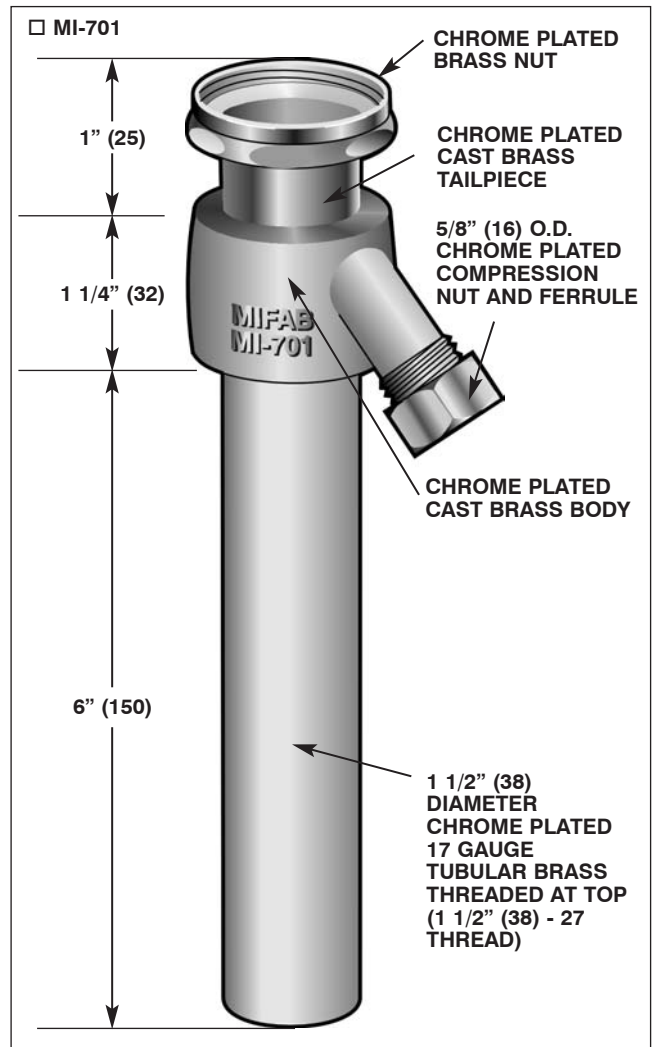
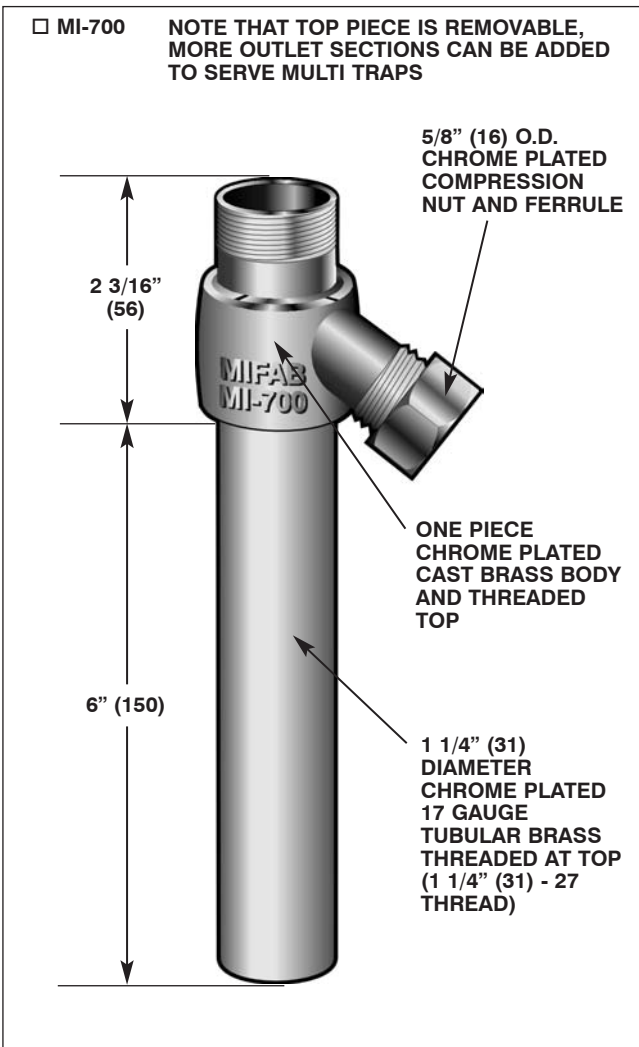
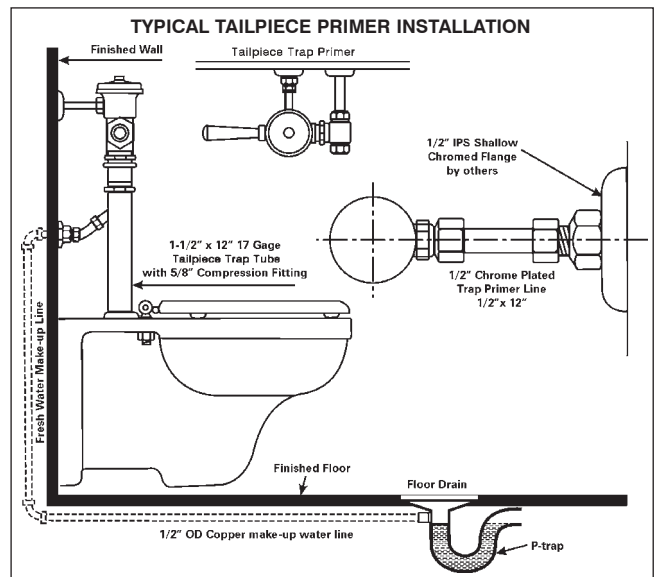

(Dimension) Denotes Millimetres



MI-702

**FLUSH VALVE
TRAP SEAL PRIMER**

Specification: MIFAB® Series MI-702 (specify length) 1 1/2" diameter, 17 gauge chrome plated tubular brass flush valve trap seal primer with vacuum breaker and 1/2" F.I.P. connection.

Functions: Used underneath flush valves to provide a supply of water that will replenish the deep seal trap or "P" trap of a drain and prevent sewer or potentially explosive methane gas from entering the area through the floor drains. Each time the flush valve is activated, a small amount of water is diverted to the floor drain.

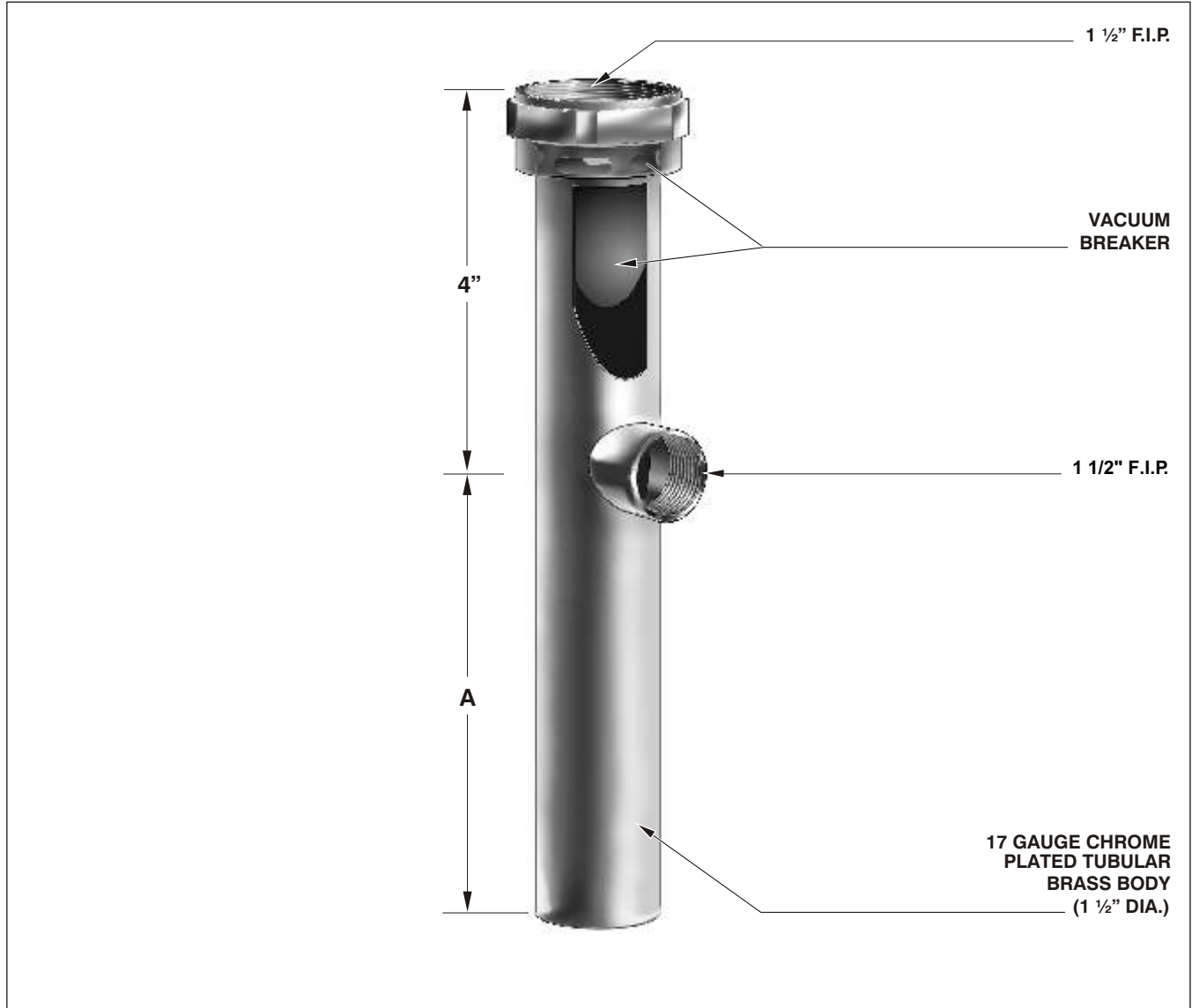

MODEL NUMBER	A	OVERALL LENGTH
MI-702-9.5	5 1/2"	9.5"
MI-702-12.5	8 1/2"	12.5"
MI-702-15.5	11 1/2"	15.5"
MI-702-23	19"	23"

OPTIONAL VARIATIONS: **SUFFIX**
 Flexible braided primer hose with chrome plated wall escutcheon and M.I.P. connection -BH

Job Name: _____	Page No: _____
Section No: _____	Contractor: _____
Schedule No: _____	Purchase Order No: _____

MIFAB reserves the right to make changes in material and design without formal notice and obligation.

USA: 1-800-465-2736 www.mifab.com CAN: 1-800-387-3880

Specification: MIFAB® Series MI-DU trap seal primer distribution unit with four brass compression outlet connections (specify -500 for 1/2" or -625 for 5/8") ABS body and H.D.PE. lid with top 1/2" M.I.P. connection, four 1/4" diameter vent holes in the flange and three 1/8" diameter Phillips head screws to secure the lid to the body. Unit complete with four wall internal body design that aligns with the slots in the underside of the lid to distribute water evenly and to only the desired number of ports.

Function: Used underneath a pressure drop activated trap seal primer to distribute water to either two, three or four floor drain traps. The lid of the distribution unit is marked with the numbers 2, 3, & 4. Remove the three lid securing screws to rotate the lid to match the desired number of drains with the guide marker pin to provide priming only to the required ports. The underside of the MI-DU is marked accordingly with numbers 1-4 to for ease in determining which ports will receive the prime. The four wall internal body design ensures that water is only directed to the selected outlets. Note: The MI-DU is factory preset to deliver priming water to ports 1 and 2. Do not over torque the three lid screws when securing the lid back onto the body. It is not necessary to install MIFAB's distribution unit perfectly level. The unique design will distribute water uniformly when out of level. Select MI-DU-500 when installing with soft copper tube (1/2" O.D.) and MI-DU-625 when installing with hard copper tube (5/8" O.D.).

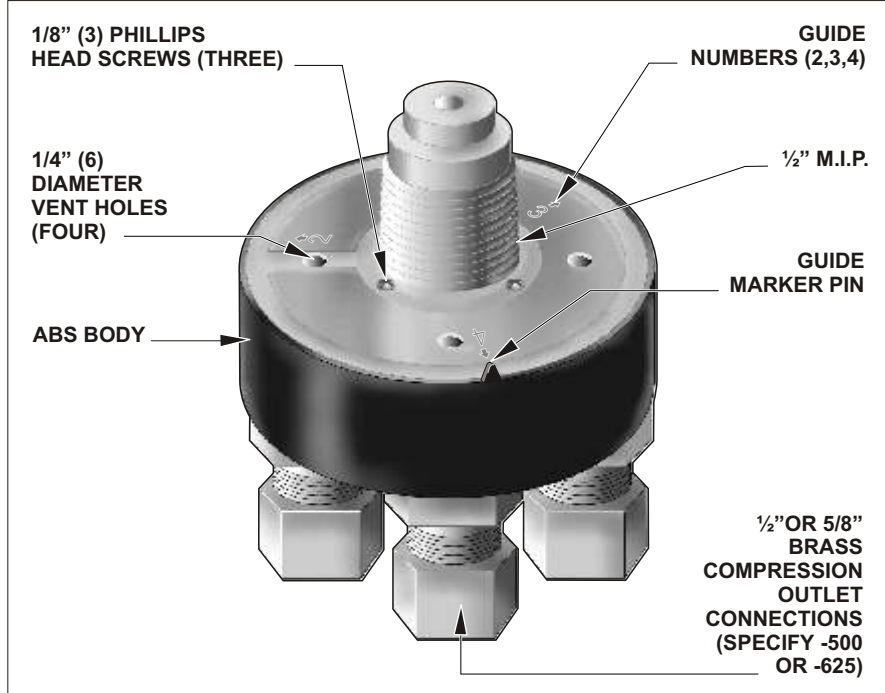

TYPICAL INSTALLATION

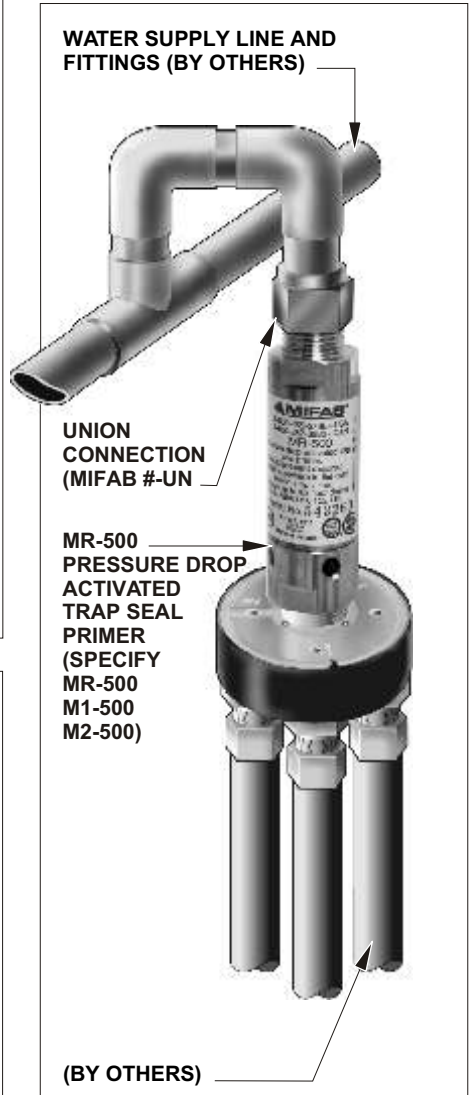

Bottom view

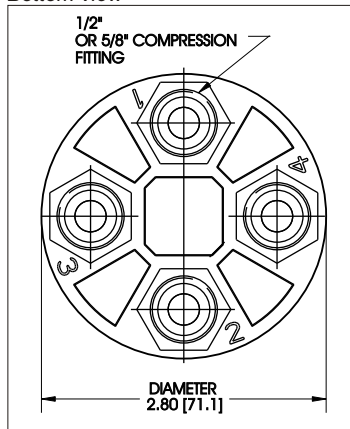

Cross section view

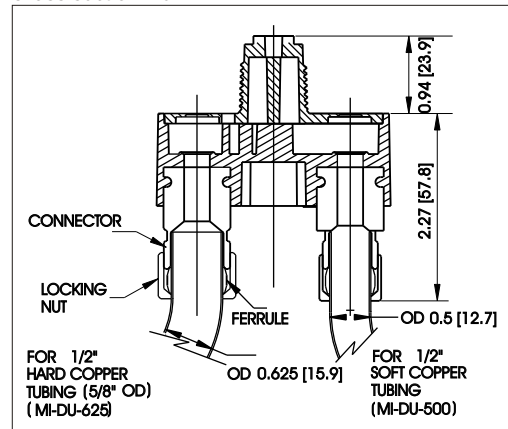

Note: U.S. Patent # 6,283,442, Canadian Patent # 2,287,103, Australia Patent #755777

OPTIONAL VARIATIONS:

- 1/2" compression connections
- 5/8" compression connections

SUFFIX

- 500
- 625

Job Name _____	Page No: _____
Section No: _____	Contractor _____
Schedule No: _____	Purchase Order No: _____



MI-TEMP AUTOMATIC PRESSURE BALANCE VALVE

Internet address: www.mifab.com

Toll Free: 1-800-465-2736

Canada Toll Free: 1-800-387-3880

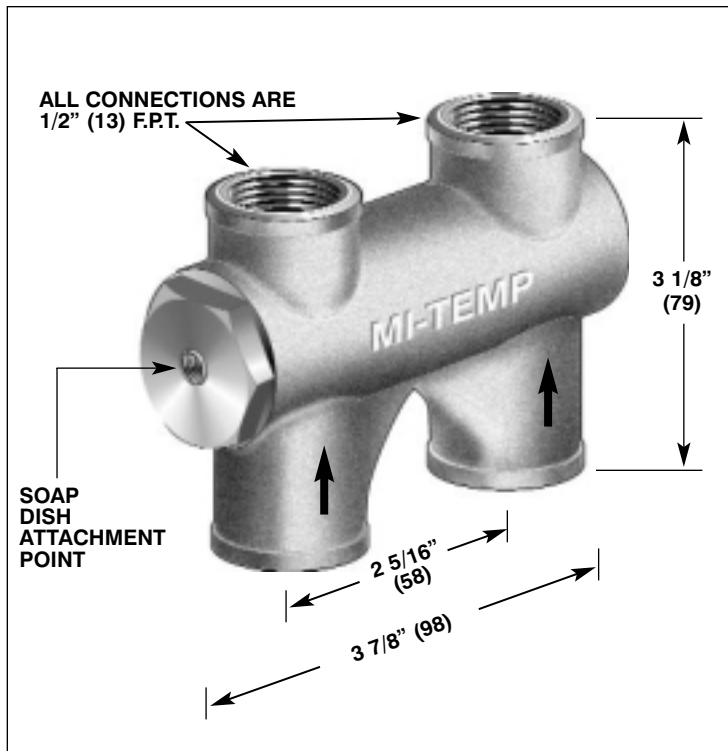

SPECIFICATION: MIFAB Series MI-TEMP automatic pressure balance valve complete with rough chrome plated cast brass body, type 304 stainless steel piston and shell and two 1/2" (13) F.P.T. inlet and two 1/2" (13) F.P.T. outlet connections. Unit complete with brass plug at end tapped 1/8" (3) for soap dish attachment. MI-TEMP is tested and certified to the A.S.S.E. 1066-97 Standard and is listed with I.A.P.M.O.

INSTALLATION: The MI-TEMP can be installed anywhere on a 1/2" (13) water supply line at any angle or position ahead of the control valve(s). When not equipped with an integral shutoff or where there is a shutoff valve installed after the control valve, there shall be stop and check valves on the inlet(s). It can be used with one or two handle valve assemblies and does not need to be installed level. Do not make direct, high temperature soldering connections to the valve body. When making a copper sweat connection, make the adapter solder joint first, then screw the connector into the valve body. The MI-TEMP should be provided with some type of access for servicing if necessary. The MI-TEMP can be installed in commercial, institutional, government, educational and residential locations - anywhere a control of water temperature is required. Do not install the MI-TEMP until ready for final inspection. Standing water will render the valve inoperable.

MAINTENANCE: Periodic flushing of accumulated debris in the valve is required by removing the shower head and opening and closing the supply valves. The MI-TEMP is resistant to calcium, sulphur, phosphorus, lime and alkali. If the MI-TEMP is not functioning due to a prolonged shut down of a system in which it is installed, the piston may be activated by opening the hot and cold water valves alternately to the full on position. Periodic cleaning of the valve is recommended. After turning off the incoming hot and cold water supply lines, remove the hexagonal nut from the valve and pull out the whole cartridge assembly. Clean it with silicon lubricant and then re-install the assembly and the hexagonal nut into the valve body.

FUNCTION: The MI-TEMP holds a selected water temperature to within one degree from any constant hot water supply regardless of pressure changes in the supply lines. It ensures a blend of mixed hot and cold water at the shower head and is fully automatic - only one moving part will equalize the hot and cold supply line pressures. As supply line pressures fluctuate, the brass piston will move enough to compensate for the change in pressure and release water only at the preselected temperature.



MI-TEMP is tested and certified to the A.S.S.E. 1066-97 Standard and is listed with I.A.P.M.O.

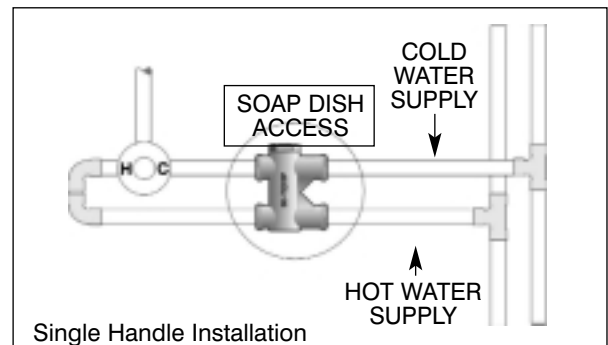
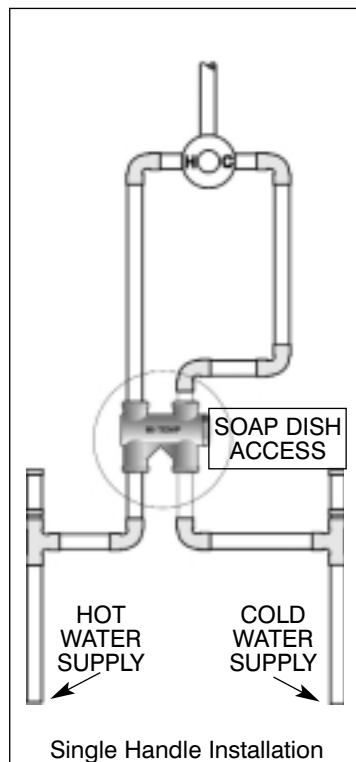
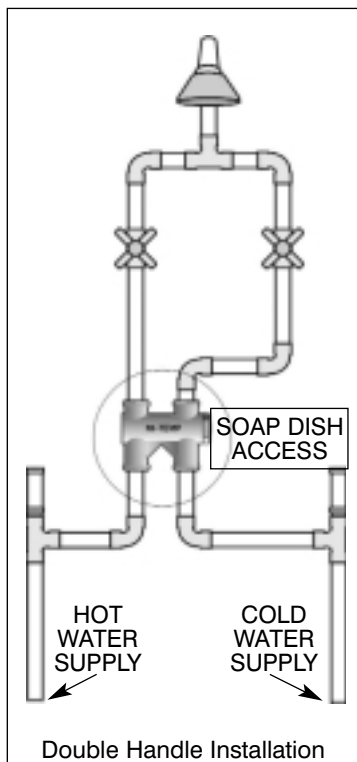

(Dimension) Denotes Millimetres

U.S. Patent # 6,138,705