



MIFAB®

F1760-FL

7" x 15" HEAVY DUTY GUTTER DRAIN WITH ANCHOR FLANGE

Specification: MIFAB® F1760-FL lacquered cast iron heavy duty gutter drain with ductile iron grate and anchor flange.

Function: Used in membrane floor and trench areas that have width limitations for surface drainage. Long rectangular grate has large free area to drain surface water quickly.

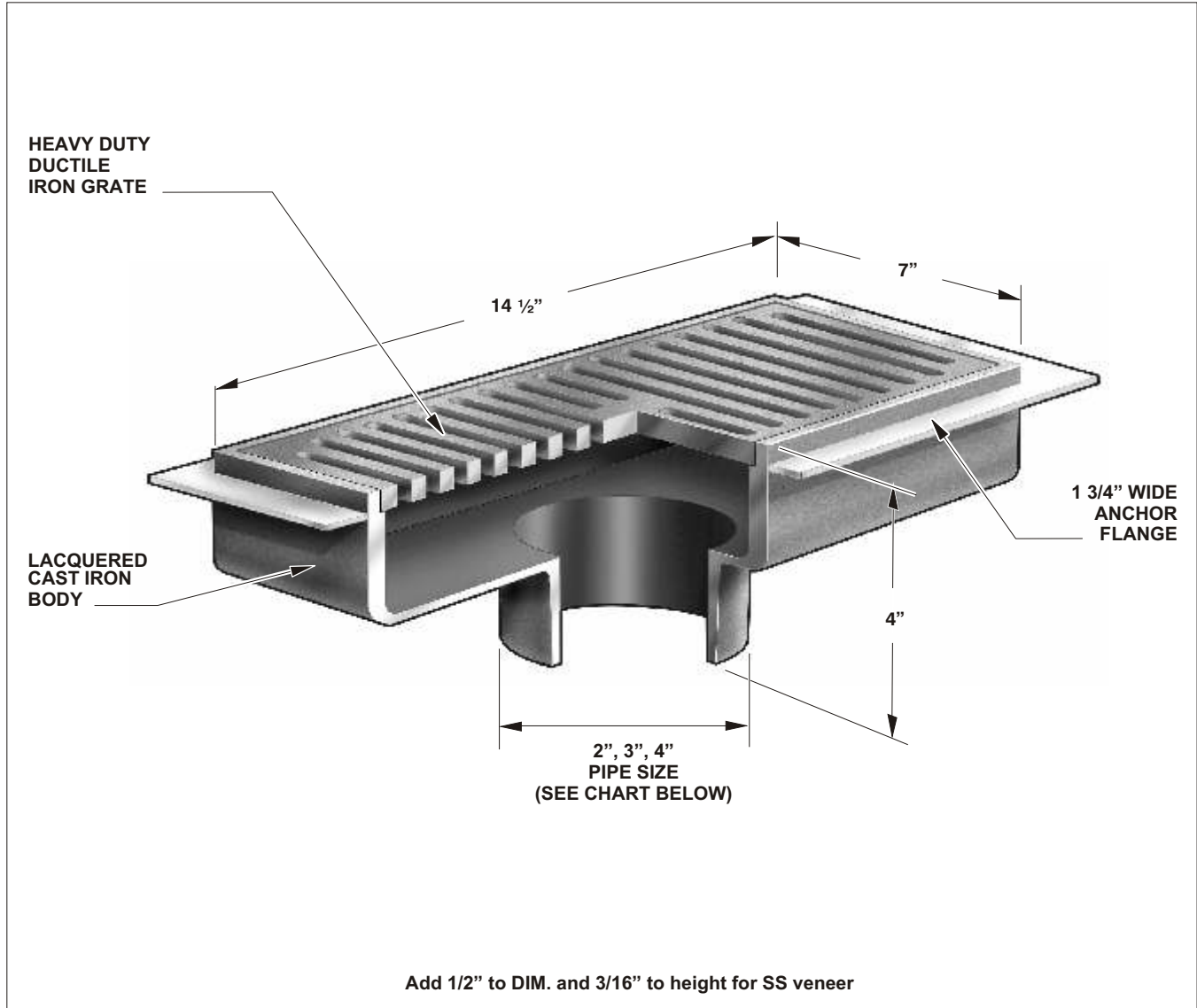

STRAINER SIZE	ANSI / ASME RATING		BODY HEIGHT				
	FREE AREA	LOAD RATING S.S. (-3) D.I. (-4)	PIPE SIZE	NO HUB (STANDARD)	PUSH ON (P)	THREADED (T)	INSIDE CAULK (X)
7" x 14 1/2" (178 x 368)	39 in ²	OVER 10,000 LBS	2" (51)	4" (102)	4 5/8" (118)	3 1/2" (89)	5" (127)
			3" (76)	4" (102)	4 5/8" (118)	3 7/8" (98)	5" (127)
			4" (102)	4" (102)	4 5/8" (118)	3 7/8" (98)	5" (127)

OPTIONAL VARIATIONS:

- Membrane clamp
- No hub outlet
- Stainless steel (veneer)
- Vandal proof secured grate
- Backwater valve

SUFFIX

- C (Standard) Acid resistant epoxy coating
- 3 All galvanized
- 6 Push on outlet
- 8 Threaded outlet
- Inside caulk outlet

SUFFIX

- 11
- 13
- P
- T
- X

Job Name _____ Page No: _____
 Section No: _____ Contractor _____
 Schedule No: _____ Purchase Order No: _____

MIFAB reserves the right to make changes in material and design without formal notice and obligation.