

F1320-C SERIES AREA DRAIN WITH 9" ROUND ADJUSTABLE HEAVY DUTY TRACTOR GRATE W/MEMBRANE CLAMP F1320-C SERIES

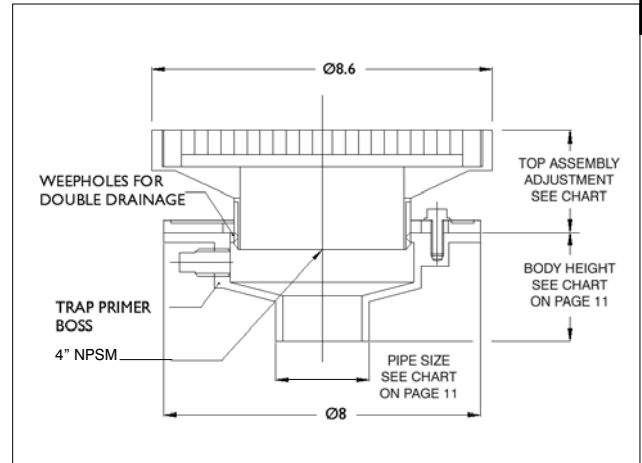
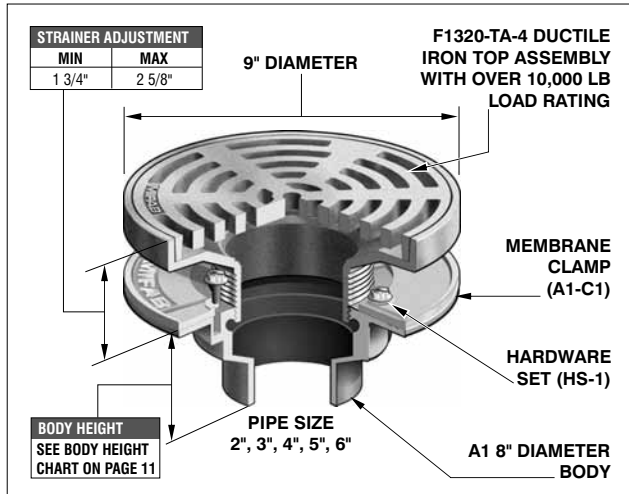

ANSI/ASME RATING		
STRAINER	FREE AREA	LOAD RATING
F1320-TA-1	18.0 IN ²	OVER 10,000 lbs
F1320-TA-3	18.0 IN ²	OVER 10,000 lbs
F1320-TA-4	18.0 IN ²	OVER 10,000 lbs

*Add 3/8" to 9" Strainer Diameter and 3/16" to Strainer Height for NB or SS Veneer

PARTS			
A1 BODY	F1320-TA- (*)	A1-C1	HS-1

F1320-C AREA DRAIN WITH 9" ROUND ADJUSTABLE HEAVY DUTY TRACTOR GRATE WITH MEMBRANE CLAMP				LIST PRICE LACQUERED CAST IRON BODY WITH:		
MODEL NUMBER	WT. Lbs	STRAINER DESCRIPTION	DUCTILE IRON (-4)	NICKEL BRONZE (-1)	STAINLESS STEEL (-3)	
F1322,3,4-C	17.50	9" Dia. Adj. tractor grate	\$427.00	\$685.00	\$685.00	
F1322,3,4-C-14	17.50	9" Dia. Adj. flat grate	\$364.00	\$624.00	\$624.00	
F1322,3,4-C-Y	17.50	9" Dia. Non-Adj. tractor grate	\$344.00	\$628.00	\$628.00	
F1322,3,4-C-Y-14	17.50	9" Dia. Non-Adj. flat grate	\$261.00	\$540.00	\$540.00	

WHEN NO MEMBRANE CLAMP IS REQUIRED, DELETE SUFFIX (-C) AND DEDUCT \$43.00

FOR F1320-C AND F1320-C-TFB OPTIONAL VARIATIONS, SEE PAGE 30

F1320-C-TFB SERIES AREA DRAIN W/9" ROUND ADJ. HEAVY DUTY TRACTOR GRATE MOUNTED IN TRUE FIT BUCKET W/MEMBRANE CLAMP F1320-C-TFB SERIES

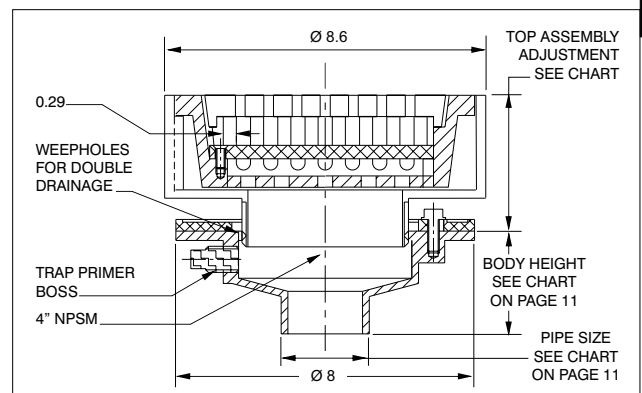
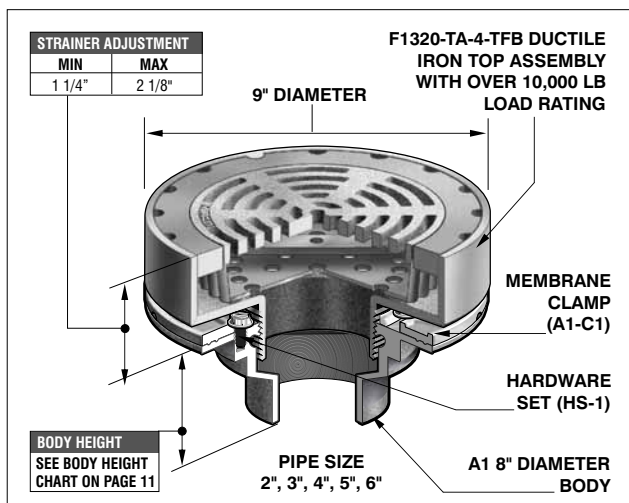

ANSI/ASME RATING		
STRAINER	FREE AREA	LOAD RATING
F1320-TFB-4	18.0 IN ²	OVER 10,000 lbs

*Add 3/8" to 9" Strainer Diameter and 3/16" to Strainer Height for NB or SS Veneer

PARTS			
A1 BODY	F1320-TA- (*)-TFB	A1-C1	HS-1

F1320-C-TFB AREA DRAIN WITH 9" ROUND ADJ. HEAVY DUTY TRACTOR GRATE MOUNTED IN TRUE FIT BUCKET W/MEMBRANE CLAMP				LIST PRICE LACQUERED CAST IRON BODY WITH:		
MODEL NUMBER	WT. Lbs	STRAINER DESCRIPTION	DUCTILE IRON (-4)	NICKEL BRONZE (-1)	STAINLESS STEEL (-3)	
F1322,3,4-C-TFB	19.00	9" Dia. Adj. tractor grate	\$307.00	\$567.00	\$567.00	

WHEN NO MEMBRANE CLAMP IS REQUIRED, DELETE SUFFIX (-C) AND DEDUCT \$43.00

Design and dimensions are subject to modification. Prices do not include applicable taxes. Visit www.mifab.com for the most recent product information.

MIFAB, Inc., 1321 West 119th Street, Chicago, Illinois 60643-5109, USA

Toll Free 1-800-465-2736, Fax 773-341-3049

All sales subject to MIFAB's Terms and Warranties. Please refer to inside front cover.

AREA DRAINS