

F1480(-FL) AREA DRAIN WITH 12" SQUARE HEAVY DUTY TRACTOR GRATE & DEEP SUMP **F1480(-FL) SERIES**

SERIES

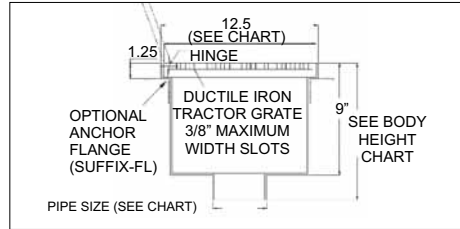

PARTS

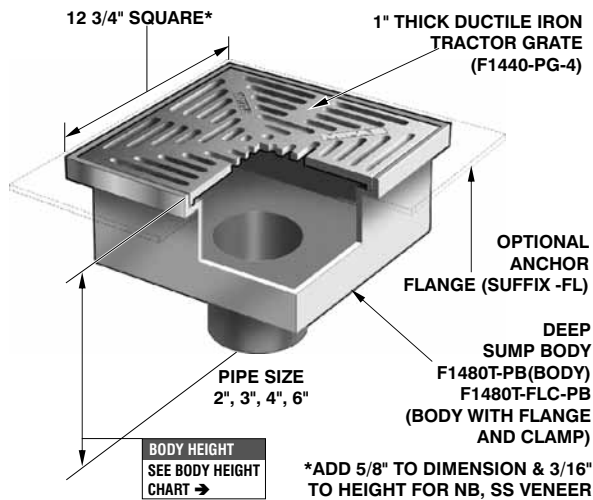
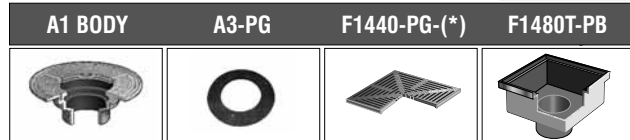

(*) Denotes strainer finish (-1, -3 or -4)

F1480 BODY HEIGHT				
PIPE SIZE	NO HUB STANDARD	PUSH ON (P)	THREADED (T)	INSIDE CAULK (X)
ALL	11" (280)	11 3/4" (289)	10" (255)	11" (280)

AREA DRAIN WITH 12" SQUARE ADJUSTABLE HEAVY DUTY HINGED TRACTOR GRATE AND DEEP SUMP BODY

MODEL NUMBER	WT. Lbs	STRAINER DESCRIPTION	LIST PRICE LACQUERED CAST IRON BODY WITH:		
			DUCTILE IRON (-4)	NICKEL BRONZE (VENEER) (-1)	STAINLESS STEEL (VENEER) (-3)
F1482,3,4,6	55.00	12" x 12" tractor grate	\$635.00	\$1231.00	\$1231.00
F1482,3,4,6-FL	55.00	12" x 12" tractor grate with anchor flange	\$825.00	\$1351.00	\$1351.00

F1480 AND F1490 OPTIONAL VARIATIONS:

SUFFIX	DESCRIPTION	F1480	F1490	SUFFIX	DESCRIPTION	F1480	F1490
-5	Sediment bucket (F1480-B)	\$ 124.00	\$ 124.00	-21	Secondary flat strainer (FD-9600 Series)	\$ 31.00	\$ 31.00
-6	Vandal proof secured grate (TR30 Torx and pin)	\$ 76.00	\$ 76.00	-22	Less grate (-4) Deduct	\$ 104.00	\$ 292.00
-7	Trap seal primer tapping	\$ 77.00	\$ 77.00	-22	Less grate (-1 or -3) Deduct	\$ 302.00	\$ 913.00
-8	Backwater valve (BV1250 Series)	\$ 195.00	\$ 195.00	-28	Stainless Steel body (Type 304)	P.O.A.	P.O.A.
-11	Acid resistant epoxy coating (Min. order 25 pcs. or P.O.A.)	\$ 538.00	\$ 719.00	-C	Membrane clamp (-FL only)	\$ 146.00	\$ 224.00
-13	All galvanized (Min. order 25 pcs. or P.O.A.)	\$ 538.00	\$ 719.00	P	Push on outlet (2", 3" or 4")	No Add	No Add
-20	Secondary dome strainer (FS1500-PD)	\$ 76.00	\$ 76.00	T	Threaded outlet (2", 3" or 4")	\$ 40.00	\$ 40.00
				X	Inside caulk outlet (2", 3" or 4")	No Add	No Add

F1490(-FL) AREA DRAIN WITH 15" SQ. ADJUSTABLE HEAVY DUTY TRACTOR GRATE & DEEP SUMP **F1490(-FL) SERIES**

SERIES

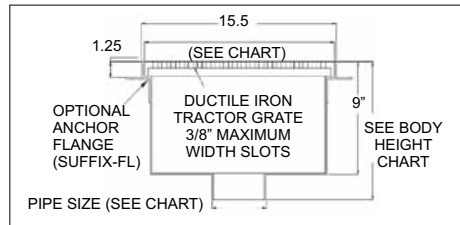
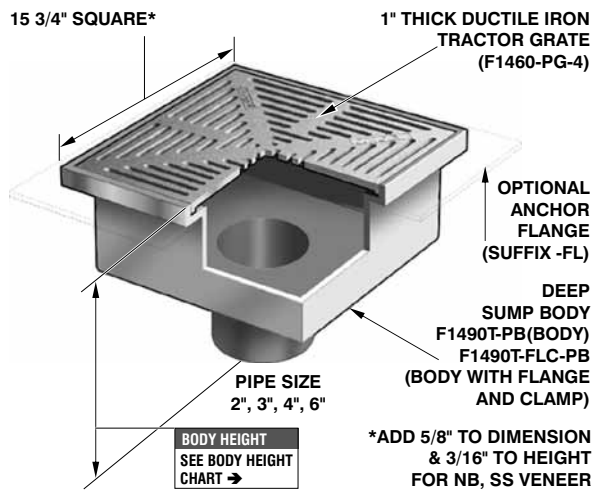

PARTS

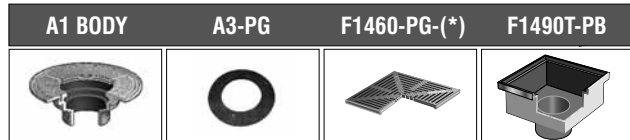

(*) Denotes strainer finish (-1, -3 or -4)

F1490 BODY HEIGHT				
PIPE SIZE	NO HUB STANDARD	PUSH ON (P)	THREADED (T)	INSIDE CAULK (X)
ALL	11 (280)	11 3/4" (289)	10" (255)	11" (280)

AREA DRAIN WITH 15" SQUARE HEAVY DUTY TRACTOR GRATE & DEEP SUMP BODY

MODEL NUMBER	WT. Lbs	STRAINER DESCRIPTION	LIST PRICE LACQUERED CAST IRON BODY WITH:		
			DUCTILE IRON (-4)	NICKEL BRONZE (VENEER) (-1)	STAINLESS STEEL (VENEER) (-3)
F1492,3,4,6	69.00	15" x 15" Tractor grate	\$1256.00	\$2547.00	\$2547.00
F1492,3,4,6-FL	69.00	15" x 15" Sq. tractor grate with anchor flange	\$1480.00	\$2736.00	\$2736.00

Design and dimensions are subject to modification. Prices do not include applicable taxes. Visit www.mifab.com for the most recent product information.

MIFAB, Inc., 1321 West 119th Street, Chicago, Illinois 60643-5109, USA

Toll Free 1-800-465-2736, Fax 773-341-3049

All sales subject to MIFAB's Terms and Warranties. Please refer to inside front cover.