

**Specification:** MIFAB® F1750 lacquered cast iron heavy duty gutter drain with ductile iron grate.

**Function:** Used in non membrane floor and trench areas that have width limitations for surface drainage. Long rectangular grate has large free area to drain surface water quickly.

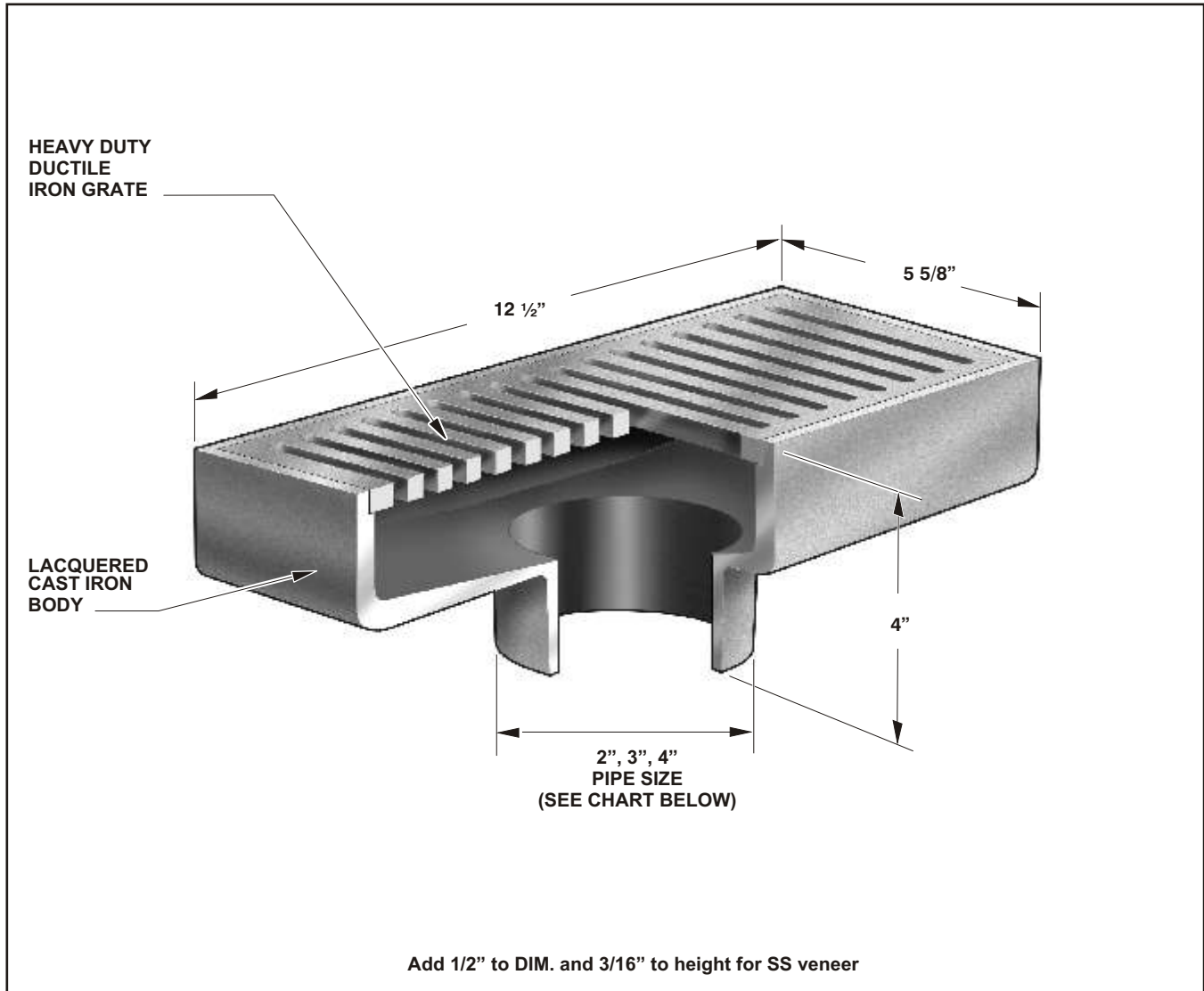

STRAINER SIZE	ANSI / ASME RATING		BODY HEIGHT				
	FREE AREA	LOAD RATING S.S. (-3) D.I. (-4)	PIPE SIZE	NO HUB (STANDARD)	PUSH ON (P)	THREADED (T)	INSIDE CAULK (X)
5 5/8" x 12 1/2" (143 x 318)	24 in <sup>2</sup>	OVER 10,000 LBS	2" (51)	4" (102)	4 5/8" (118)	3 1/2" (89)	5" (127)
			3" (76)	4" (102)	4 5/8" (118)	3 7/8" (98)	5" (127)
			4" (102)	4" (102)	4 5/8" (118)	3 7/8" (98)	5" (127)

**OPTIONAL VARIATIONS:**

- Anchor flange
- Anchor flange with membrane clamp
- No hub outlet
- Stainless steel (veneer)
- Vandal proof secured grate
- Backwater valve

**SUFFIX**

- FL
- FLC
- (Standard)
- 3
- 6
- 8

**SUFFIX**

- Acid resistant epoxy coating -11
- All galvanized -13
- Push on outlet P
- Threaded outlet T
- Inside caulk outlet X

Job Name _____	Page No: _____
Section No: _____	Contractor _____
Schedule No: _____	Purchase Order No: _____