

Specification: MIFAB® F1790 lacquered cast iron indirect waste funnel with backwater valve.

Function: Used in hospitals and laboratories with indirect waste lines installed above the floor. The funnel will receive condensate, drip or waste water from the indirect waste lines. MIFAB's MI-950 deep seal trap connected to MIFAB's M-500 Series of trap seal primers are recommended for use with the F1790 to prevent sewer gases from entering the room.

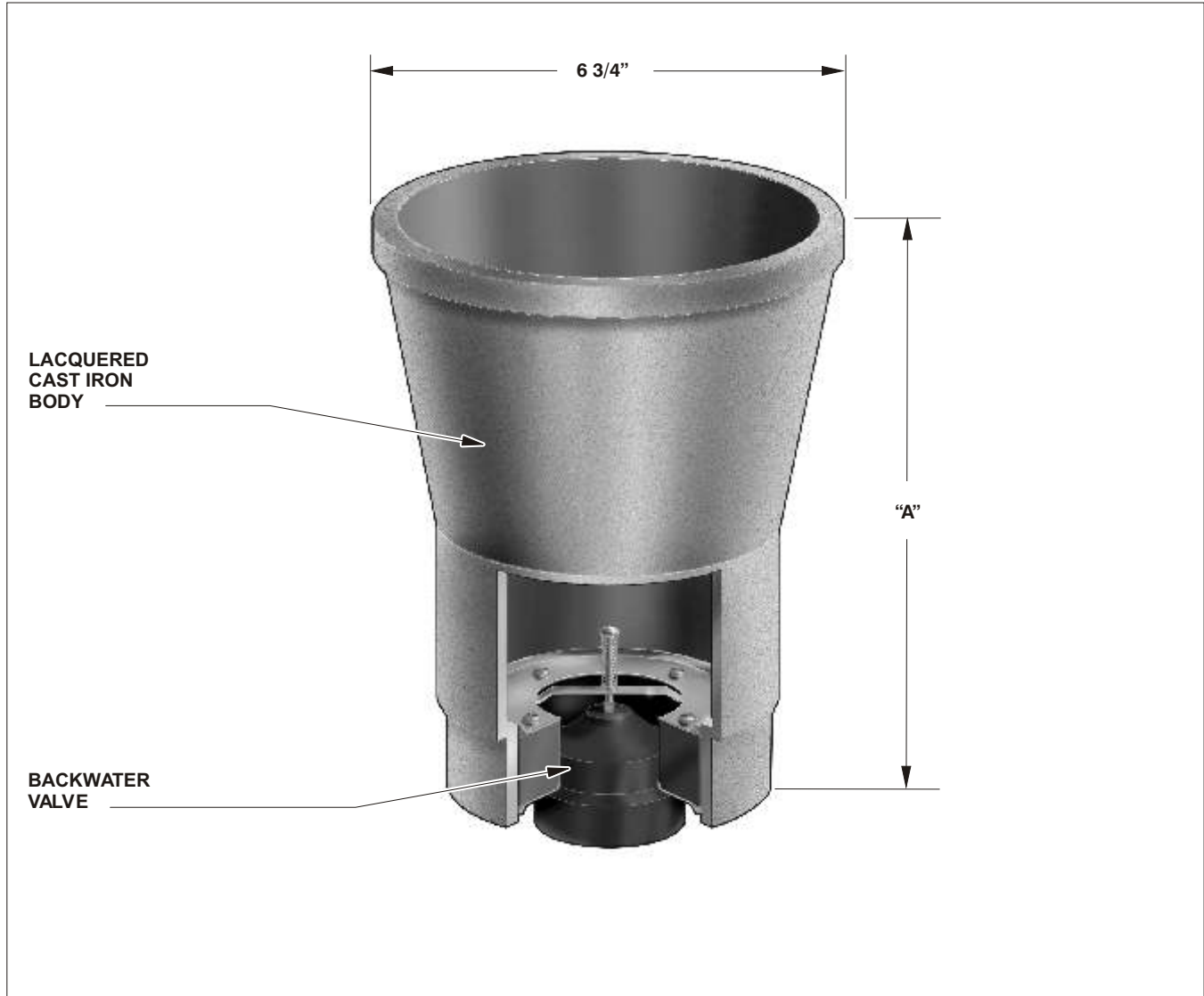

PIPE SIZE	BODY HEIGHT "A"		
	NO HUB (STANDARD)	PUSH ON (P)	PVC / ABS (-30) / (-31)
2" (51)	10" (254)	10 3/8" (263)	10 3/8" (263)
3" (76)	10" (254)	10 3/8" (263)	10 3/8" (263)
4" (102)	10" (254)	10 3/8" (263)	10 3/8" (263)
6" (152)	8 3/4" (222)	-	-

OPTIONAL VARIATIONS:

- No hub outlet
- Push on outlet
- Acid resistant epoxy coating
- All galvanized

SUFFIX

- (Standard)
- P
- 11
- 13
- Secondary dome strainer
- Secondary flat strainer
- PVC socket connection body
- ABS socket connection body

SUFFIX

- 20
- 21
- 30
- 31

Job Name _____	Page No: _____
Section No: _____	Contractor _____
Schedule No: _____	Purchase Order No: _____