

F1100-C-EF SERIES FLOOR DRAIN WITH ROUND ADJUSTABLE STRAINER AND 4" FUNNEL

F1100-C-EF SERIES

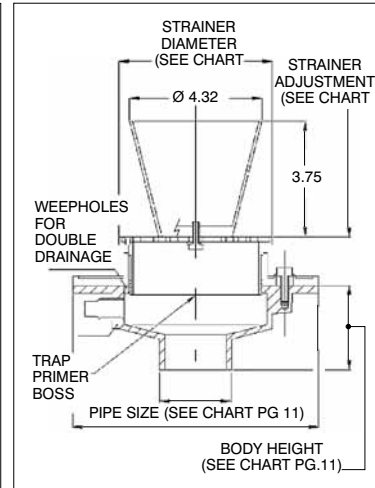
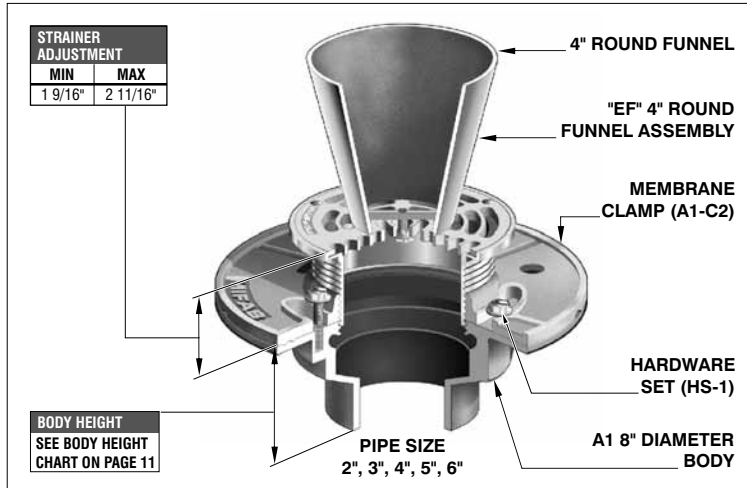

FLOOR DRAINS

FLOOR DRAIN WITH ADJUSTABLE 4" DIA. FUNNEL STRAINER

MODEL NUMBER	WT. Lbs	STRAINER SIZE	LIST PRICE: NICKEL BRONZE (-1) STAINLESS STEEL (-3)	LIST PRICE CAST IRON (-50)
F1102,3,4-C-EF	9.50	5" DIA	\$467.00	-
F1102,3,4-C-EF-50	9.50	5" DIA	-	\$309.00

WHEN NO MEMBRANE CLAMP IS REQUIRED, DELETE SUFFIX (-C) AND DEDUCT \$43.00

(*) Denotes strainer finish (-1, -3, -50)

F1100-C-AS, F1100-C-DD, F1100-C-EF, and F1100-C-EG SERIES OPTIONAL VARIATIONS: CONT FROM P. 12

SUFFIX	DESCRIPTION	LIST PRICE	SUFFIX	DESCRIPTION	LIST PRICE
-49	Chrome plated strainer assembly (-add to 1 only)	\$ 15.00	-J-(1,3)	3" x 1" NB or SS oval funnel	P.O.A.
-90	Threaded side outlet (2", 3")	\$ 112.00	-J-50	3" x 1" cast iron oval funnel	P.O.A.
	4" threaded side outlet	\$ 159.00	P	Push on outlet (2", 3" or 4")	No Add
-95	Client logo (10 piece Min. Order)	P.O.A.	T	Threaded outlet (2", 3" or 4")	\$ 40.00
-C	Membrane clamp (A1-C2)	\$ 43.00	-Z	Extended wide elastomeric flange (13" Dia. x 1/8" Thick)	P.O.A.
-C1	Low rough-in membrane clamp (A1-C1)	\$ 43.00	X	Inside caulk outlet (2", 3" or 4")	No Add
-F4-(1,3)	4" NB or SS round funnel	\$ 218.00	5	5" no hub outlet	\$ 284.00
-F4-50	4" cast iron round funnel	\$ 91.00	5T	5" threaded outlet	\$ 284.00
-F6-(1,3)	6" NB or SS round funnel	\$ 325.00	5X	5" inside caulk outlet	\$ 284.00
-F6-50	6" cast iron round funnel	\$ 147.00	6	6" no hub outlet	\$ 284.00
-G-(1,3)	4" x 9" NB or SS oval funnel	\$ 454.00	6P	6" push on outlet*	\$ 284.00
-G-50	4" x 9" C.I. oval funnel	\$ 218.00			

* Specify POG-6 for C.I. pipe and POG-6-PVC pipe. 2", 3", 4" sizes use same gasket.

F1100-C-EG SERIES FLOOR DRAIN WITH ROUND STRAINER AND 4"x 9" ELONGATED FUNNEL

F1100-C-EG SERIES

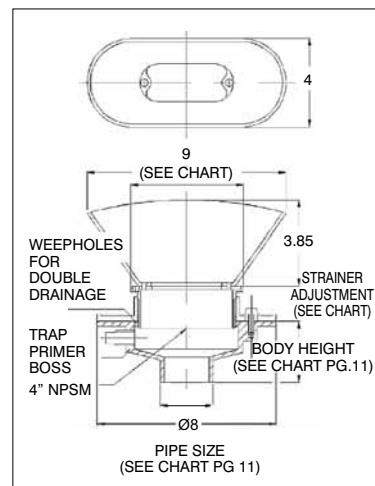
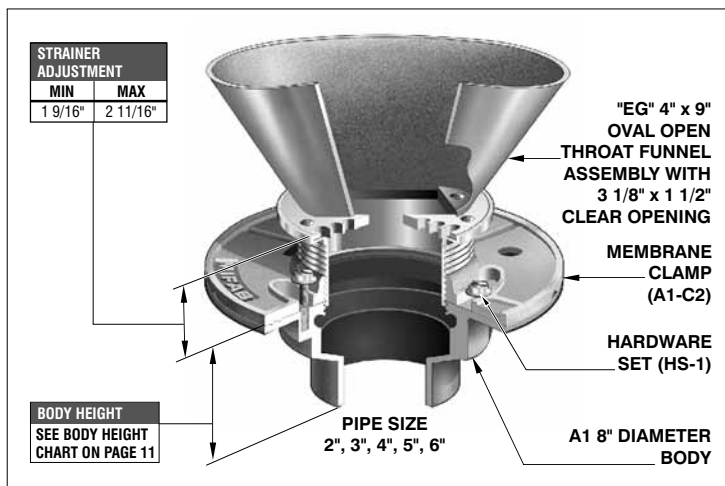

FLOOR DRAINS

FLOOR DRAIN WITH ADJUSTABLE 4" x 9" FUNNEL INDIRECT STRAINER

MODEL NUMBER	WT. Lbs	STRAINER SIZE	LIST PRICE: NICKEL BRONZE (-1) STAINLESS STEEL (-3)	LIST PRICE CAST IRON (-50)
F1102,3,4-C-EG	10.00	5" DIA	\$703.00	-
F1102,3,4-C-EG-50	10.00	5" DIA	-	\$438.00

WHEN NO MEMBRANE CLAMP IS REQUIRED, DELETE SUFFIX (-C) AND DEDUCT \$43.00

(*) Denotes strainer finish (-1, -3, -50)

All sales subject to MIFAB's Terms and Warranties. Please refer to inside front cover.

Design and dimensions are subject to modification. Prices do not include applicable taxes. Visit www.mifab.com for the most recent product information.

MIFAB, Inc., 1321 West 119th Street, Chicago, Illinois 60643-5109, USA

Toll Free 1-800-465-2736, Fax 773-341-3049

All sales subject to MIFAB's Terms and Warranties. Please refer to inside front cover.