



HY-2000

ENCASED NON-FREEZE WALL HYDRANT

Specification: MIFAB® Series HY-2000 _____ (specify length) A.S.S.E. 1019-B certified exposed type, self draining, non freeze wall hydrant with A.S.S.E. 1011 approved anti-siphon and vandal resistant integral vacuum breaker with 3/4" (19) male hose connection. Hydrant assembly complete with neoprene plunger to control both the flow and drain functions, hardened bronze operating stem, drain port under the hexagon nut, heavy duty brass casing, 360 degree swivel inlet connection, heavy duty chrome plated bronze head casting, polished chrome plated face plate and satin finished nickel bronze box with hinged locking cover. Operating key to be furnished with each hydrant.

Applications: Designed to blend in with commercial applications such as office buildings, apartment complexes, malls and shopping centers, schools, churches and industrial buildings.

Plumbing and Drainage
Mechanical Section

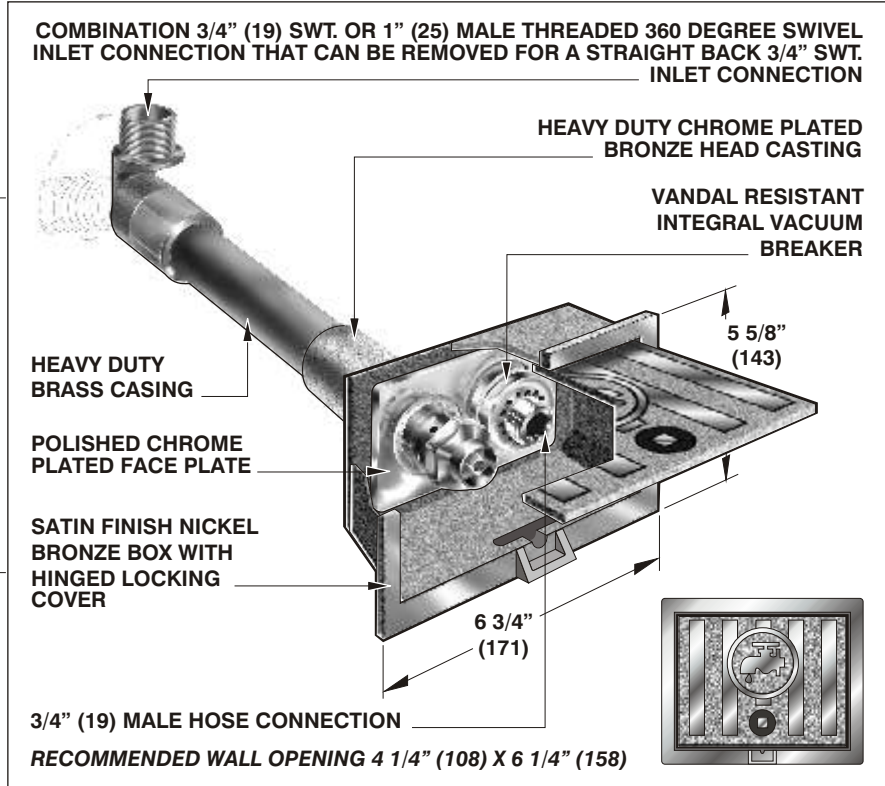

Overhead view

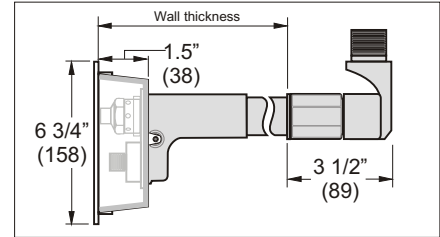

MIFAB® HY-2000 Series Features

- **SWIVEL CONNECTION** - 360 degree combination 3/4" SWT. and 1" male threaded inlet connection. Swivel connection can be removed for 3/4" SWT. straight back inlet.
- **VACUUM BREAKER** - unique vandal resistant integral vacuum breaker protects owner from anti-siphon conditions. Self draining.
- **FACE PLATE** - polished chrome plated.
- **HYDRANT BOX** - satin finished nickel bronze.
- **CASING** - heavy duty brass casing tube.
- **APPROVALS** - HY-2000 Series wall hydrant is tested and certified by C.S.A. to the A.S.S.E. Standard 1019-B. The anti-siphon vacuum breaker is tested and certified by C.S.A. to the A.S.S.E. Standard 1011.



(Dimension) Denotes Millimetres

MODEL NO.	WALL THICKNESS		OVERALL LENGTH		APPROXIMATE WEIGHT		SWIVEL INLET CONNECTION
	IN	MM	IN	MM	Lbs.	Kg.	IN
HY-2006	6	152	10	254	7.0	3.18	3/4", SWT., 1" Male IPS combination
HY-2008	8	203	12	306	7.5	3.41	3/4", SWT., 1" Male IPS combination
HY-2010	10	254	14	357	8.0	3.64	3/4", SWT., 1" Male IPS combination
HY-2012	12	305	16	406	8.5	3.86	3/4", SWT., 1" Male IPS combination
HY-2014	14	356	18	457	9.0	4.09	3/4", SWT., 1" Male IPS combination
HY-2016	16	406	20	508	9.5	4.32	3/4", SWT., 1" Male IPS combination
HY-2018	18	457	22	559	10.5	4.77	3/4", SWT., 1" Male IPS combination
HY-2020	20	508	24	610	10.5	4.77	3/4", SWT., 1" Male IPS combination
HY-2024	24	610	28	711	11.5	5.00	3/4", SWT., 1" Male IPS combination

OPTIONAL VARIATIONS:

- 1" (25) Hose connection -0
- Cast stainless steel hydrant box -3
- Polished chrome plated nickel Bronze box -49

SUFFIX

- A.S.S.E 1052 double check vacuum breaker. HY-1600 deep rough in Stainless Steel box required -52
- Three mounting brackets fastened to top and two sides of box for frame installation -BR

SUFFIX

- Cylinder key lock -
- Four 1" x 1/4" (25 x 6) slots on top and two sides of box to receive mounting brackets -S
- Wall clamp -WC

Job Name: _____ Page No: _____
 Section No: _____ Contractor: _____
 Schedule No: _____ Purchase Order No: _____

MIFAB reserves the right to make changes in material and design without formal notice and obligation.

USA: 1-800-465-2736 www.mifab.com CAN: 1-800-387-3880