

F1100-C-FT SERIES FLOOR DRAIN WITH RECESSED TILE FLANGE

F1100-C-FT SERIES

FLOOR DRAINS

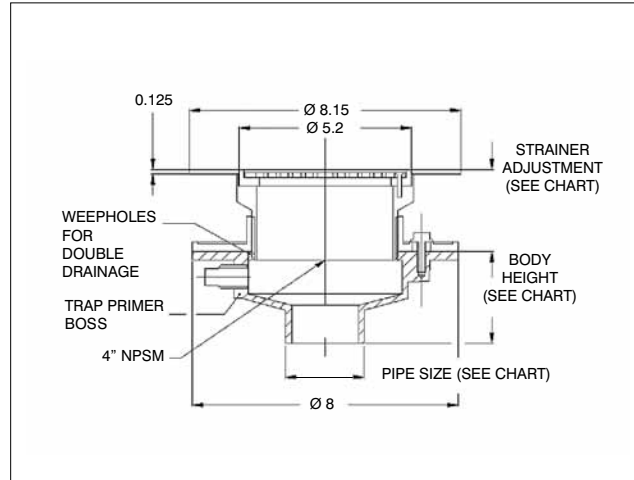
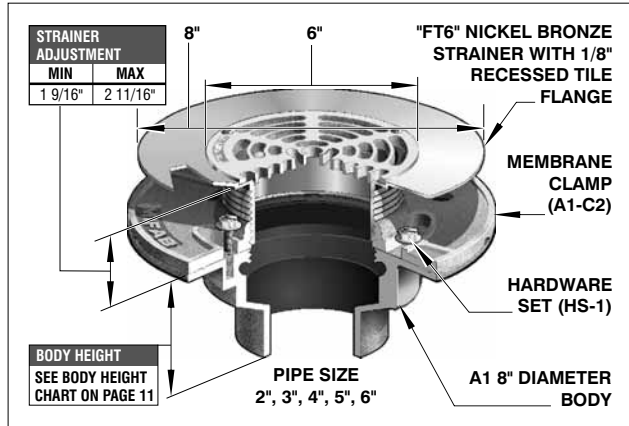

ANSI/ASME RATING		
STRAINER	FREE AREA	LOAD RATING
FT6-1	9 IN ²	UP TO 2000 lbs
FT6-3	9 IN ²	5000-7499 lbs

FLOOR DRAIN WITH RECESSED TILE FLANGE			
MODEL NUMBER	WT. Lbs	STRAINER SIZE	LIST PRICE: NICKEL BRONZE (-1) STAINLESS STEEL (-3)
F1102,3,4-C-FT6	10.50	6\"/>	

WHEN NO MEMBRANE CLAMP IS REQUIRED, DELETE SUFFIX (-C) AND DEDUCT \$43.00

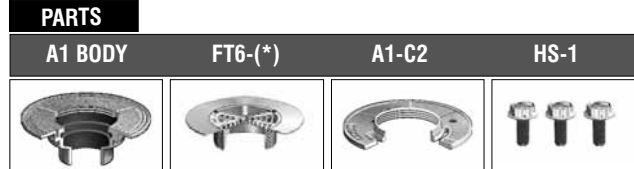

(* Denotes strainer finish (-1 or -3))

F1100-C-ER, F1100-C-FC, F1100-C-FT AND F1100-C-HG SERIES OPTIONAL VARIATIONS CONTINUED FROM PAGE 14

SUFFIX	DESCRIPTION	LIST PRICE	SUFFIX	DESCRIPTION	LIST PRICE
-49	Chrome plated strainer assembly (add to -1only)	\$ 15.00	-J-(1,3)	3\"/>	

F1100-C-HG SERIES FLOOR DRAIN WITH ROUND ADJUSTABLE HINGED STRAINER

F1100-C-HG SERIES

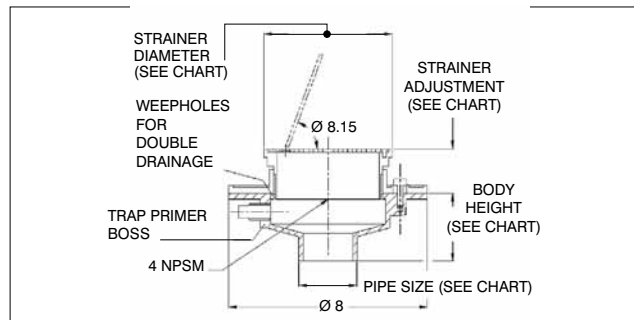
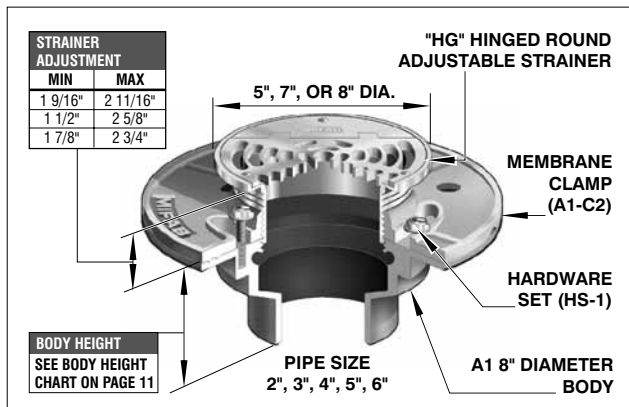

FLOOR DRAIN WITH ROUND ADJUSTABLE HINGED STRAINER			
MODEL NUMBER	WT. Lbs	STRAINER SIZE	LIST PRICE STAINLESS STEEL (-3)
F1102,3,4-C-HG5	8.50	5\"/>	

WHEN NO MEMBRANE CLAMP IS REQUIRED, DELETE SUFFIX (-C) AND DEDUCT \$43.00

All sales subject to MIFAB's Terms and Warranties. Please refer to inside front cover.

Design and dimensions are subject to modification. Prices do not include applicable taxes.

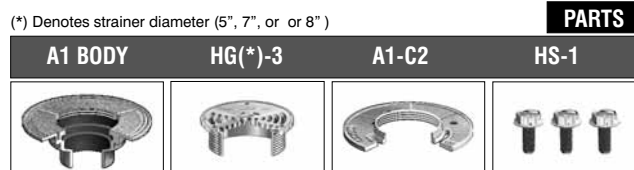

ANSI/ASME RATING		
STRAINER	FREE AREA	LOAD RATING
HG5-3	8 IN ²	5000-7499 lbs
HG7-3	9 IN ²	5000-7499 lbs
HG8-3	18.0 IN ²	5000-7499 lbs

Visit www.mifab.com for the most recent product information.