

F1120-C TERRACE DRAIN WITH INTEGRAL DEEP SEAL TRAP

F1120-C SERIES

SERIES

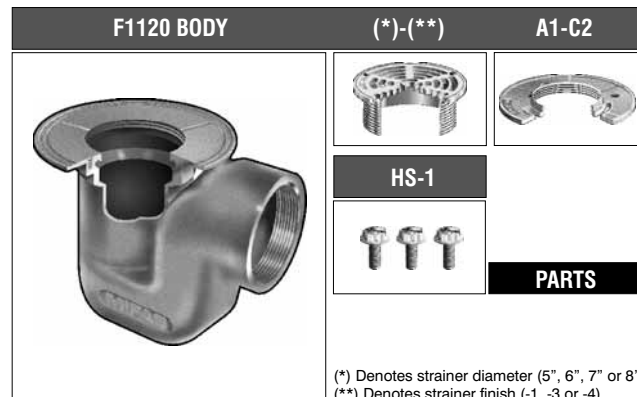
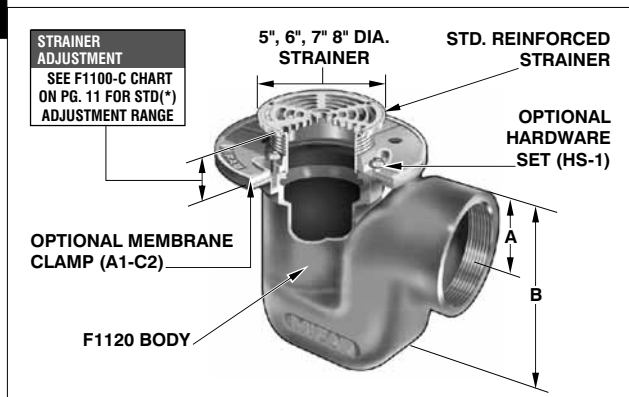

(*) Denotes strainer diameter (5", 6", 7" or 8")
 (**) Denotes strainer finish (-1, -3 or -4)

TERRACE DRAIN WITH INTEGRAL DEEP SEAL TRAP					
MODEL NUMBER	WT. Lbs	OUTLET SIZE	STRAINER SIZE	LIST PRICE: NICKEL BRONZE (-1) STAINLESS STEEL (-3)	LIST PRICE DUCTILE IRON (-4)
F1122,3-C-5	15.00	2", 3"	5" DIA	\$440.00	\$409.00
F1124-C-5	16.00	4"	5" DIA	\$608.00	\$577.00
F1122,3-C-6	17.00	2", 3"	6" DIA	\$492.00	-
F1124-C-6	18.00	4"	6" DIA	\$660.00	-
F1122,3-C-7	17.50	2", 3"	7" DIA	\$541.00	-
F1124-C-7	18.50	4"	7" DIA	\$709.00	-
F1122,3-C-8	19.00	2", 3"	8" DIA	\$631.00	\$534.00
F1124-C-8	20.00	4"	8" DIA	\$799.00	\$702.00

ANSI/ASME RATING	
SEE F1100-C CHART ON PG. 11 FOR RATINGS	

BODY HEIGHT		
PIPE SIZE	A	B
2"*	2 1/4"	5 3/16"
3"*	2 1/2"	5 3/16"
4"*	2 3/4"	7 3/8"

*ABOVE DIMENSIONS FOR STANDARD THREADED OR OPTIONAL NO HUB OUTLET

*ADD SUFFIX -NH FOR NO HUB ADAPTOR, FOR 2" ADD \$49.00, FOR 3" ADD \$71.00, FOR 4" ADD \$112.00
 WHEN NO MEMBRANE CLAMP IS REQUIRED, DELETE SUFFIX (-C) AND DEDUCT \$43.00

F1120-C, F1130C AND F1140C SERIES OPTIONAL VARIATIONS					
SUFFIX	DESCRIPTION	LIST PRICE	SUFFIX	DESCRIPTION	LIST PRICE
-5	Sediment bucket (A1-PB)	\$ 56.00	-F4-(1,3)	4" NB or SS round funnel	\$ 218.00
-6	Security screws (TR25 Torx and pin)	\$ 28.00	-F4-50	4" cast iron round funnel	\$ 91.00
-7	Trap seal primer tapping	\$ 77.00	-F6-(1,3)	6" NB or SS round funnel	\$ 325.00
-8	Backwater valve (BV1254) (Cannot use with -5)	\$ 195.00	-F6-50	6" cast iron round funnel	\$ 147.00
-13	Galvanized body (Min. order 25 pcs. or P.O.A)	\$ 212.00	-G-(1,3)	4"x9" NB or SS oval funnel	\$ 454.00
-15	Extension (DD-50)	\$ 71.00	-G-50	4"x9" C.I. oval funnel	\$ 218.00
-15	Extension (F1130C, F1140C) (2 pcs DD-50)	\$ 142.00	-J-(1,3)	3"x1" NB or SS oval funnel	P.O.A.
-AI	Auxiliary inlet (specify 1 1/2" or 2")	\$ 178.00	-J-50	3"x1" cast iron oval funnel	P.O.A.
-C	Membrane clamp (except F1120)	No add	*-NH	No hub outlet (F1120 only)	See MI-850

FOR OPTIONAL STRAINERS, SEE PAGES 24 AND 25

F1130C FLOOR DRAIN WITH INTEGRAL DEEP SEAL TRAP AND CLEANOUT

F1130C SERIES

SERIES

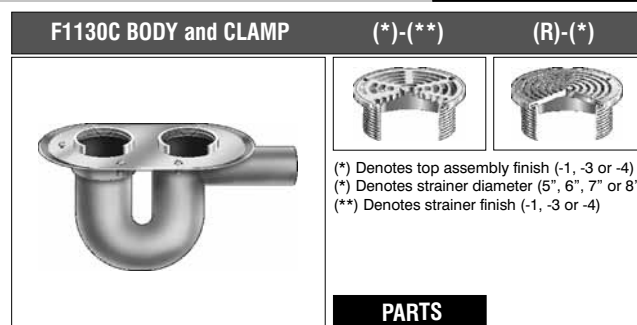
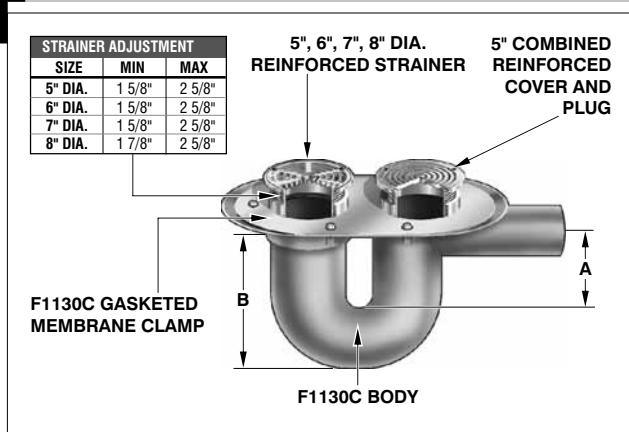

(*) Denotes top assembly finish (-1, -3 or -4)
 (*) Denotes strainer diameter (5", 6", 7" or 8")
 (**) Denotes strainer finish (-1, -3 or -4)

FLOOR DRAIN WITH INTEGRAL DEEP SEAL TRAP AND CLEANOUT					
MODEL NUMBER	WT. Lbs	OUTLET SIZE	STRAINER SIZE	LIST PRICE: NICKEL BRONZE (-1) STAINLESS STEEL (-3)	LIST PRICE DUCTILE IRON (-4)
F1132,3,4C-5	41.00	2", 3", 4"	5" DIA	\$731.00	\$702.00
F1132,3,4C-6	43.00	2", 3", 4"	6" DIA	\$785.00	-
F1132,3,4C-7	45.00	2", 3", 4"	7" DIA	\$833.00	-
F1132,3,4C-8	47.00	2", 3", 4"	8" DIA	\$922.00	\$827.00

COVER ADJUSTMENT	
MIN	MAX
1 5/8"	2 5/8"

BODY HEIGHT		
PIPE SIZE	A	B
2" NO HUB	5 3/8"	13 1/2"
3" NO HUB	6"	13 1/2"
4" NO HUB	6 1/4"	13 1/2"

Design and dimensions are subject to modification. Prices do not include applicable taxes. Visit www.mifab.com for the most recent product information.

MIFAB, Inc., 1321 West 119th Street, Chicago, Illinois 60643-5109, USA

Toll Free 1-800-465-2736, Fax 773-341-3049

All sales subject to MIFAB's Terms and Warranties. Please refer to inside front cover.