

Falcon F35 & F45 Digital Panel Meters



- 1/8 DIN Indicator
- 3-1/2 or 4-1/2 digit bright red LED display
- Front panel pops off for easy decimal point setting and display scaling
- Only 3.12" (79mm) required behind panel
- Optional excitation output
- NEMA 4X enclosure optional
- Din Rail Adapter available (page C1)

Mounting Requirements

The Falcon series 1/8 DIN indicators require a panel cutout of 1.77" (45mm) high by 3.62" (92mm) wide. To install the Falcon into a panel cutout, remove the clips from the side of the meter. Slide the meter through your panel cutout, then slide the mounting clips back on the meter. Press evenly to ensure a proper fit. Tighten screws.

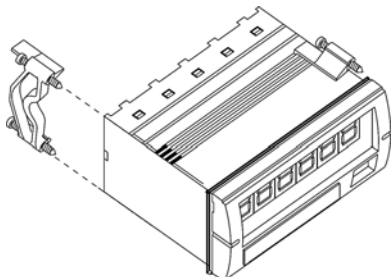

Specifications

DISPLAY	
Type	7-segment, red LED
Height	0.56" (14.2mm)
Decimal Point	user-programmable, internally or on the terminal block
Overrange indication	most significant digit = "1"; other digits blank
Polarity	Automatic, with "-" indication, "+" indication implied
POWER REQUIREMENTS	
AC Voltages	120 or 220VAC, ±10% 50/60Hz
DC Voltages	9-32DCV, ±1%
Power Consumption	F35: 3VA, F45: 2VA
ACCURACY @25°C	
F45 DC Process/Voltage	±0.02% of reading ± 1 count
F35 DC Process/Voltage	±0.1% of reading ± 1 count
F45 DC Current	±0.05% of reading ±1 count
	2A ± 5 counts 5A ± 5 counts
F35 DC Current	±0.1% of reading ± 1 count
	2A ± 5 counts, 5A ± 5 counts
F45 AC Voltage/Current	±0.5% of reading ± 35 counts
F35 AC Voltage/Current	±1% of reading ± 5 counts (45Hz-1KHz)
ENVIRONMENTAL	
Operating Temperature	0 to 55°C
Storage Temperature	-10 to 60°C
Relative Humidity	0 to 85% non-condensing
Warm-up Time	Less than 15 minutes
NOISE REJECTION	
NMRR	F35=50dB, 50/60Hz; F45=60dB, 50/60Hz
CMRR	(w/1KΩ unbalanced @ 60Hz) 90dB min.
A TO D CONVERSION	
Technique	Dual slope integration
Rate	F35=3 samples per second, nominal; F45=2.5 samples per second, nominal
MECHANICAL	
Bezel	3.78" x 1.89" x .51"
Depth	2.94"
Panel Cutout	3.62" X 1.77"
Case Material	94V-1, UL rated Noryl®
Weight	9.0oz (255.1g)
Temperature Coefficient	
F35 AC/TRMS (Voltage/Current)	(±0.1% ± 0.5 count)/°C
F35 DC (Voltage/Current/Process)	(±0.01% ± 0.05 count)/°C
F45 AC (Voltage/Current)	(±0.05% ± 0.5 count)/°C
F45 DC Current	(±0.01% ± 0.1 count)/°C
F45 DC (Voltage/Process)	(±0.05% ± 0.1 count)/°C

Dimensions

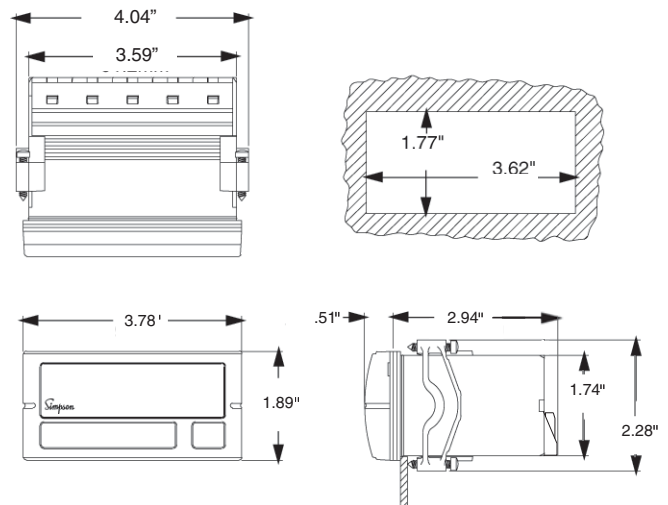

more >>



Falcon F35 & F45 Digital Panel Meters

A
8

Specifications for F35 Frequency Meters

DISPLAY

Type 7-segment, red LED
Height 0.56" (14.2mm)

Overrange indication Most significant digit = "1"; other digits blank

POWER REQUIREMENTS

AC Voltages 120 or 220VAC, $\pm 10\%$ 50/60Hz
Power Consumption 2.5VA min./4VA max.

ACCURACY @25°C

200 Hz: $\pm 0.2\%$ of input ± 0.2 Hz
2 KHz: $\pm 0.2\%$ of input ± 2 Hz

INPUT LEVEL

500mV to 250V RMS at 1.0M Ω impedance OR 5V to 24V Square Wave (DC offset 2V maximum)

Resolution: 200Hz = 0.1Hz
2kHz = 1Hz

ENVIRONMENTAL

Operating Temperature 0 to 55°C
Storage Temperature -10 to 60°C
Relative Humidity 0 to 85% non-condensing @ 40°C
Temperature Coefficient ($\pm 0.05\%$ of input ± 0.5 count)/°C
Warm-up Time Less than 15 minutes

CONVERSION

Technique Frequency-to-voltage
Rate 3 samples per second, nominal

Specifications for F45 Temperature Meters

DISPLAY

Type 7-segment, red LED
Height 0.56" (14.2mm)
Decimal Point Jumper-selectable 2-position (corresponding to resolution desired)

Overrange indication Most significant digit = "1"; other digits blank

Polarity Automatic, with "-" indication, "+" indication implied

POWER REQUIREMENTS

AC Voltages 120 or 220 ACV, $\pm 10\%$ 50/60Hz
DC Voltages 9-32 DCV, $\pm 1\%$
Power Consumption 3VA

ENVIRONMENTAL

Operating Temperature 0 to 55°C
Storage Temperature -10 to 60°C
Relative Humidity 0 to 85% non-condensing
Warm-up Time Less than 20 minutes

INPUTS

Thermocouple J, K, E, T, R, and S
RTD Platinum 100 (.00385 alpha), 2, 3 or 4 wire
Millivolt ± 84 mV reading of uncompensated mV
Input Impedance 7M Ω (typical)
Conversion Rate 2-1/2 times per second
Open Thermocouple Detection -1 on display, -40nA bias on thermocouple

Temperature			
Sensor Type	Temperature Range	Accuracy	Resolution
E	-200 to 1000°C	$\pm 0.1\%$ of rdg $\pm 1^\circ\text{C}$ $\pm 0.1\%$ of rdg $\pm 1.8^\circ\text{F}$	0.1 or 1 Degree User Selectable
	-328 to 1832°F		
J	-200 to 1200°C		
	-328 to 2192°F		
K	-200 to 1372°C		
	-328 to 2501°F		
T	-200 to 400°C		
	-328 to 752°F		
RTD Pt 100	-200 to 850°C		
	-328 to 1562°F		
R, S	-50 to 1768°C	1 Degree Automatic	
	-58 to 3214°F		
mV	Voltage Range	$\pm 0.02\%$ of rdg ± 1 count	0.01 mV
	± 84.00 mV		
mV	Voltage Range	$\pm 0.02\%$ of rdg ± 1 count	0.001mV
	-19.999mV to +84.000mV		

Inputs

DC Voltage					
Range	F35		F45		Max Input (Unfused)
	Resolution	Input Impedance	Resolution	Input Impedance	
200mV	100uV	>100MEG	10uV	>100MEG	100V
2V	1mV	>10MEG	100uV	>10MEG	250V
20V	10mV	>10MEG	1mV	>9.9MEG	250V
200V	100mV	>9.9MEG	10mV	>9.8MEG	250V

AC TRMS Voltage					
Range	F35		F45		Max Input (Unfused)
	Resolution	Input Impedance	Resolution	Input Impedance	
200mV	100uV	>100MEG	10uV	>100MEG	100V
2V	1mV	>1MEG	100uV	>1MEG	250V
20V	10mV	>10MEG	1mV	>1MEG	250V
200V	100mV	>9.9MEG	10mV	>1MEG	250V

DC / AC TRMS Current				
Range	Resolution		Voltage Drop	Max Input (Unfused)
	F35	F45		
200uA	100nA	10nA	200mV	10mA
2mA	1uA	100nA		40mA
20mA	10uA	1uA		100mA
200mA	100uA	10uA		500mA
2A	1mA	100uA		2.2A
5A	10mA	1mA		5.2A

DC Process					
Range	F35		F45		Max Input (Unfused)
	Resolution	Input Impedance	Resolution	Input Impedance	
4 to 20mA	10uA	NA	1uA	NA	200mV
1 to 5Vdc	10mV	>10MEG	1mV	>9.9MEG	NA
0 to 10Vdc	10mV	>10MEG	1mV	>9.9MEG	NA

Falcon F35 & F45 Digital Panel Meters



Ordering Information

Falcon Indicators can be configured by making an entry in each section. Example: F35-1-52-0.



Selection	Description	Selection	Description
Basic Unit		Function/Range cont'd	
F35	3 1/2 digit LED	61	200 AC μ A TRMS •
F45	4 1/2 digit LED	62	2 ACmA TRMS •
Power Supply		63	20 ACmA TRMS •
1	120 ACV	64	200 ACmA TRMS •
2	220 ACV	65	2 ACA TRMS •
3	9-32 DCV†	66	5 ACA TRMS •
Function/Range		71	4-20 DCmA Process
11	200 DCmV	72	1-5 DCV Process
12	2 DCV	73	0-10 DCV Process
13	20 DCV	80 (F45)	J T/C
14	200 DCV	81 (F45)	K T/C
21	200 D μ A	82 (F45)	S T/C
22	2 DCmA	83 (F45)	T T/C
23	20 DCmA	84 (F45)	E T/C
24	200 DCmA	85 (F45)	R T/C
25	2 DCA	86 (F45)	DCmV
26	5 DCA	90 (F45)	RTD Pt100 Ohm
31	200 ACmV	91 (F35)	20-199.9 Hz RMS
32	2 ACV	92 (F35)	20-1999 Hz RMS
33	20 ACV	93 (F35)	20-199.9 Hz Sq. Wave
34	200 ACV	94 (F35)	20-1999 Hz Sq. Wave
41	200 A μ A	Excitation Output	
42	2 ACmA	(not available with AC, temperature, or frequency inputs)	
43	20 ACmA	0	None
44	200 AC mA	1	12 DCV @ 25mA max. current
45	2 ACA	2	24 DCV @ 25mA max. current
46	5 ACA	Display Scaling	
51	200 ACmV TRMS •	(Temperature units only)	
52	2 ACV TRMS •	C	°C
53	20 ACV TRMS •	F	°F
54	200 ACV TRMS •		

† Not available for use with frequency meters

• Only available with F35