



**capital**  
SAFETY

A Capital Safety Company

***Hoists, Davits,  
Bases & Accessories***



W W W - U C I S a f e t y s y s t e m s - c o m

# CONTENTS

History of Unique Concepts Limited .....	2
UCL Advanced 4 Piece Hoist Systems .....	3
UCL Advanced 5 Piece Hoist Systems .....	4
Davits & Mast Extensions .....	5
Portable Bases .....	6
Portable Bases - Manhole Collars .....	7
Fixed Bases .....	8
Fixed Bases (continued) .....	9
Fixed Base Accessories & Carrying Bags....	10
Ladder Hanger & Accessories .....	11
Winch Bracket, Carts & Accessories .....	12



Unique Concepts has specialized in the design and manufacture of confined space, fall protection & rescue systems for over 18 years. Our unique experience in this field allows us to offer products and services that can be copied, but never equaled.

1. *ISO 9001:2000 Registered.* Unique Concepts is constantly improving our design and manufacturing process to provide unparalleled service to our customers.
2. *Quality Standards.* Unlike others, Unique Concepts keeps as much of its design and manufacture as possible under our own control to ensure the highest quality of manufacture and parts.
3. *Certified Welding Inspected by Third Party Experts.* Our welding is certified by the Canadian Welding Bureau (CWB) to Canadian Standards Associations (CSA) standards.
4. *Experienced Design.* Our customers benefit from the wealth of experience our long serving managerial and design staff brings to bear on any question. We hold 18 patents, and more are coming.
5. *Third Party Validation of Systems.* We physically test our products at our facility. Our specifications sheets are certified by Delta-T Engineering, who witness & validate our tests. BSI, from the United Kingdom, provides our third party CE testing and reporting services.
6. *Modular Approach to Systems.* One system does not work for all applications! Our systems are engineered to be modular. One system can be easily adapted to many different situations. The result: less costly and more effective solutions.
7. *Custom Design and Manufacture.* Not in our catalogues? Let's talk. You may be surprised by what we can do for you. We amaze our customers with solutions that work for their specific applications. Chances are we have already designed a product that can be modified or adapted for your needs.
8. *Constant Innovation.* Unique Concepts is constantly looking for ways to improve existing products and develop new ones. We have constantly reinvested 5% of gross revenue into research and development.

You are reading the brochure highlighted below:

Look for these additional UCL Accessory brochures marked \* to accompany this catalogue:

### Hoists, Davits, Bases & Accessories - #9700101

\* Vehicle Hitch Mount Sleeve - #9700102

\* Counterweight Systems - #9700103

\* Winches & Brackets - #9700104

Tripods & Accessories - #9700105

Pole Hoist - #9700106

Side Entry/Tank Pod Systems - #9700107

Portable Fall Arrest Systems - #9700108

Engineered Systems - #9700109

Portable Tanker Access Ladder Sys. - #9700110

Basic Hoists - #9700111

Fold Up Hoist - #9700112

Glide 360 Rail System - #9700113

UCL Product Summary - #9700114



## 4 Piece Hoist Systems



**18501**

The **UCL Advanced 4 Piece Hoist System Model #: 18501** includes the one-piece 12" - 29" adjustable offset mast (pt#: 18382) and three-piece lightweight base (pt#: 18005).

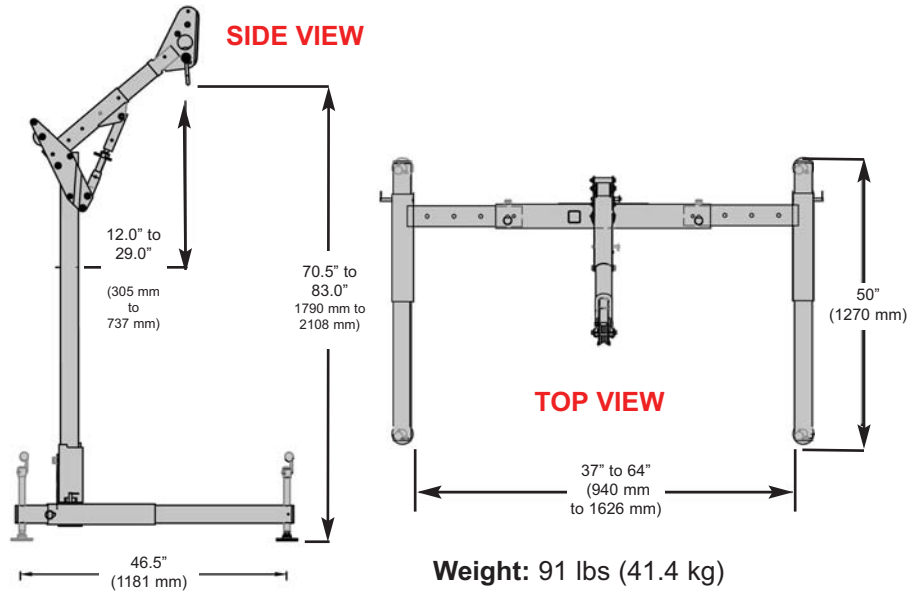

Price	Part #	Description
	18501	UCL Advanced 4 Piece System
	18512	Set of two carrying bags for 18501 4 Piece Hoist System



**18502**

The **UCL Advanced 4 Piece Hoist System Model #: 18502** includes the one-piece 30" - 48" adjustable offset mast (pt#: 18385) and three-piece lightweight base (pt#: 18008).

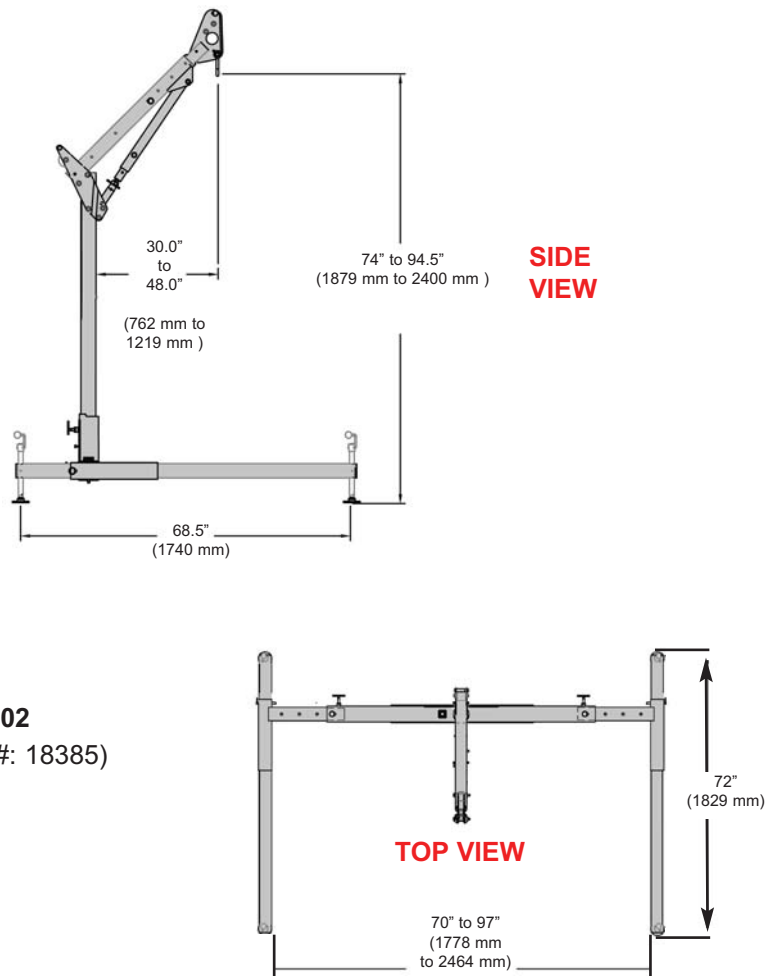

Price	Part #	Description
	18502	UCL Advanced 4 Piece System

**Weight: 128 lbs (58.2 kg)**

# 5 Piece Hoist Systems



**18000**

The **UCL Advanced 5 Piece Hoist System Model #: 18000** includes the 12" - 29" adjustable offset mast (pt#: 18001), 33" lightweight lower mast (pt#: 18002) and three-piece lightweight base (pt#: 18005).

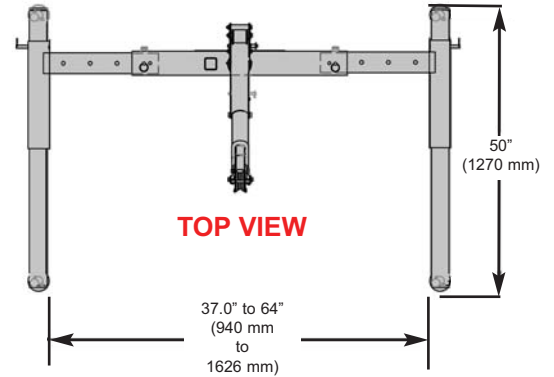
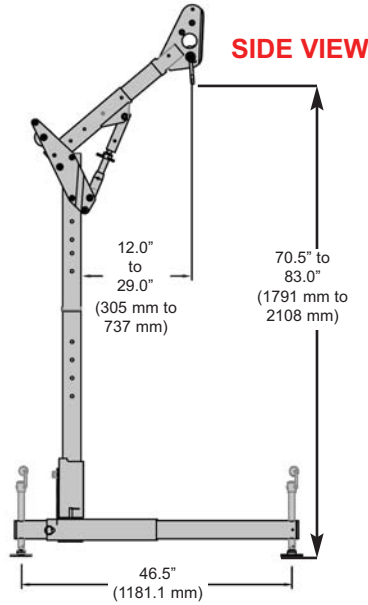

**Weight: 100 lbs (45.5 kg)**

Price	Part #	Description
<input type="text"/>	18000	UCL Advanced 5 Piece System
<input type="text"/>	18513	Set of two carrying bags for 18000 5 Piece Hoist System



**18040**

The **UCL Advanced 5 Piece Hoist System Model #: 18040** includes the 30" - 48" adjustable offset mast (pt#: 18006), 33" lightweight lower mast (pt #: 18002) and three-piece lightweight base (pt#: 18008) for spanning larger vaults or tanks.

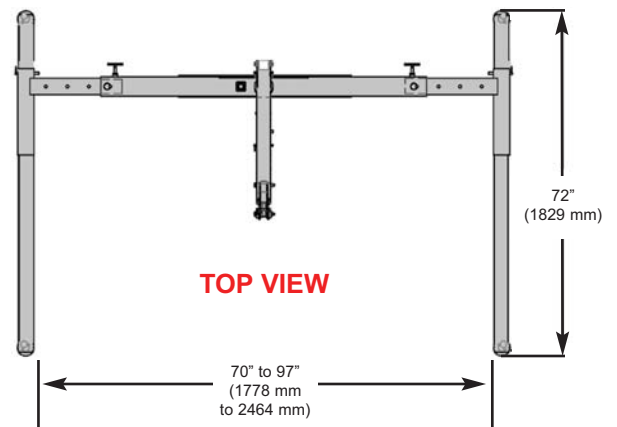
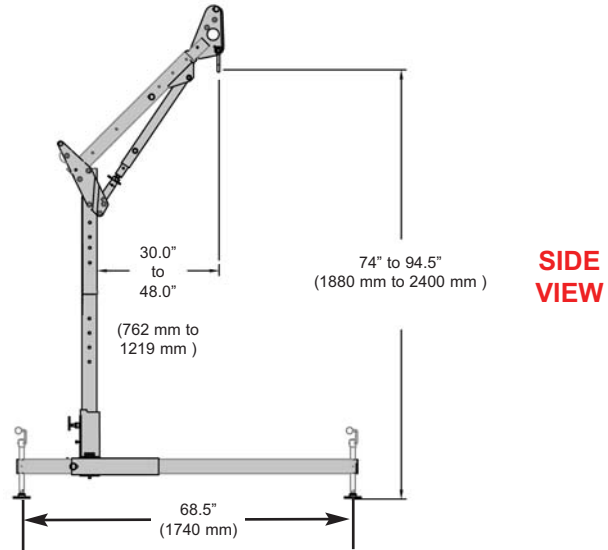

Price	Part #	Description
<input type="text"/>	18040	UCL Advanced 4 Piece System

**4 Weight: 137.5 lbs (62.5 kg)**

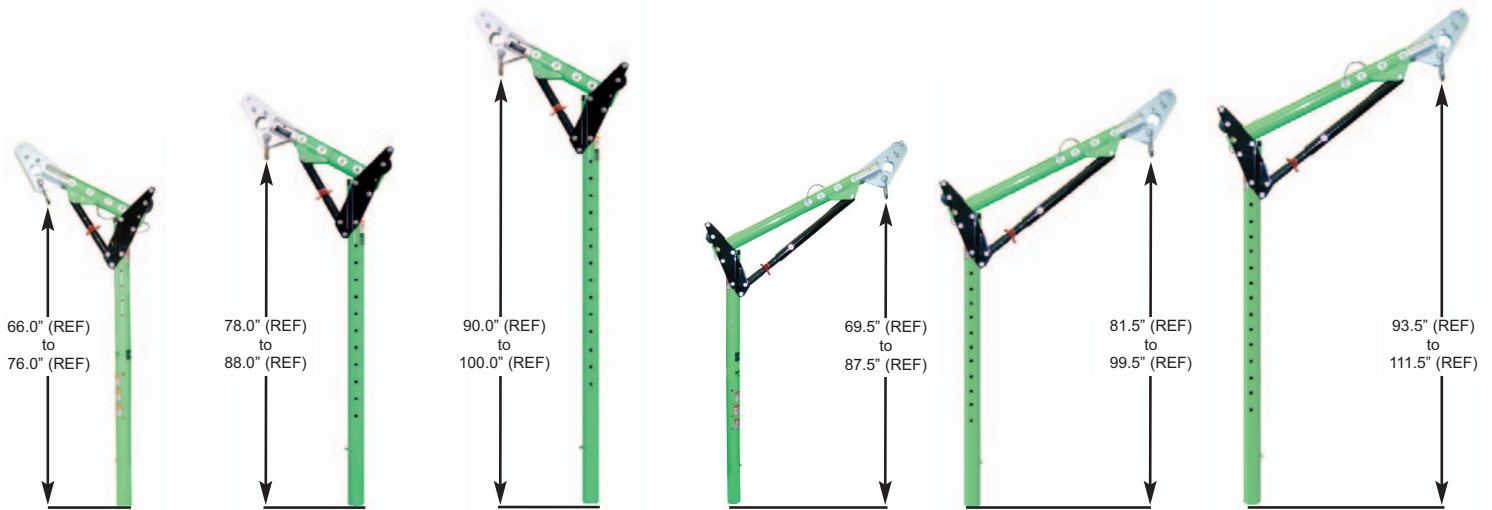

**12" (305 mm) - 29" (737 mm) Davit Adjustment**

<b>18382</b> 66" (1676 mm) to 76" (1930 mm) Price: <input type="text"/> Weight: 31 lbs (14.1 kg)	<b>18383</b> 78" (1981 mm) to 88" (2235 mm) Price: <input type="text"/> Weight: 34 lbs (15.5 kg)	<b>18384</b> 90" (2286 mm) to 100" (2540 mm) Price: <input type="text"/> Weight: 37 lbs (16.8 kg)
--	--	---

**30" (762 mm) - 48" (1219 mm) Davit Adjustment**

<b>18385</b> 69.5" (1765 mm) to 87.5" (2223 mm) Price: <input type="text"/> Weight: 36 lbs (16.4 kg)	<b>18386</b> 81.5" (2070 mm) to 99.5" (2527 mm) Price: <input type="text"/> Weight: 39 lbs (17.7 kg)	<b>18387</b> 93.5" (2375 mm) to 111.5" (2832 mm) Price: <input type="text"/> Weight: 42 lbs (19.1 kg)
--	--	---

**Davit - Upper & Lower Masts**

*Masts can be equipped with up to 2 winch brackets pt#: 16824 (Not included). Please see page 12 for more information.*

*Working length lower mast/extensions for use only with Advanced Series Davit. Combine up to 2 lower mast extensions to increase the anchorage height. \*Some restrictions may apply. Call UCL for more information.*



**Upper Davit**

<b>18001</b> 12" (305 mm) to 29" (737 mm) Price: <input type="text"/> Weight: 22 lbs (10 kg)	<b>18006</b> 30" (762 mm) to 48" (1219 mm) Price: <input type="text"/> Weight: 27.5 lbs (12.5 kg)
--	---

**Lower Masts / Extensions**

<b>18509</b> 21" (533 mm) Price: <input type="text"/> Weight: 15 lbs (6.8 kg)	<b>18002</b> 33" (838 mm) Price: <input type="text"/> Weight: 18 lbs (8.2 kg)	<b>18003</b> 45" (1143 mm) Price: <input type="text"/> Weight: 21 lbs (9.5 kg)	<b>18004</b> 57" (1448 mm) Price: <input type="text"/> Weight: 24 lbs (10.9 kg)
---	---	--	---

## Portable Bases

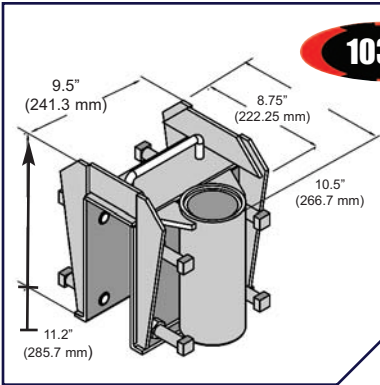

**10323**

**Barrel Mount Sleeve w/ 3.5" Opening:** Mild steel construction. Eight independent clamping screws allow temporary installations over edges of shoring cans, walls and other structures. Comes with PVC inner liner.

Price:	Part #	Description
	10323	Barrel Mount Sleeve w/ 3.5" Opening (Mild Steel)
	10429	Barrel Mount Sleeve w/ 3.5" Opening (Stainless Steel) SPECIAL ORDER.

Weight: 36.5 lbs (16.6 Kg)

Custom fit openings available. Please call.

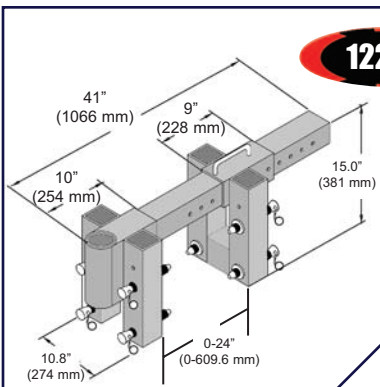

**12285**

**Adjustable Barrel Mount Sleeve:** Designed for shoring, wall & parapet applications where frequent set-up over varying wall thicknesses is required. Standard unit accommodates wall thicknesses up to a maximum of 24", with shorter or longer adjustment tubes available on request. Anodized, welded aluminum with zinc plated steel hardware for lightweight durability. Comes with inner sleeve.

Price:	Part #	Description
	10715	Adjustable Barrel Mount Sleeve with 12" max opening (Anodized Aluminum)
	12285	Adjustable Barrel Mount Sleeve with 24" max opening (Anodized Aluminum)
	16088	Adjustable Barrel Mount Sleeve with 42" max opening (Anodized Aluminum)

Custom sizes are available. Please call for more information.

Weight: 56 lbs (25.5 Kg)

## Three Piece Portable Bases

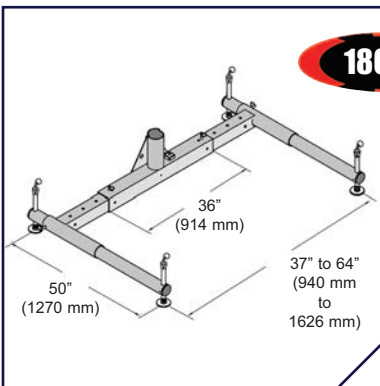

**18005**

Constructed of powder coated aluminum, the base features adjustable aluminum screws & built in level indicator for easy set-up on uneven surfaces. The base disassembles & collapses without tools into 3 lightweight components for transport & storage. Carrying bag available. See page 10.

**Advanced 3 Piece Expandable Base for Max. 30" Offset**

Price:	Part #	Description
	18005	Advanced 3 Pc Expandable Base for Max. 30" Offset
	13565	Carrying Bag for 3 Piece Base

Weight: 60 lbs (27.3 Kg)

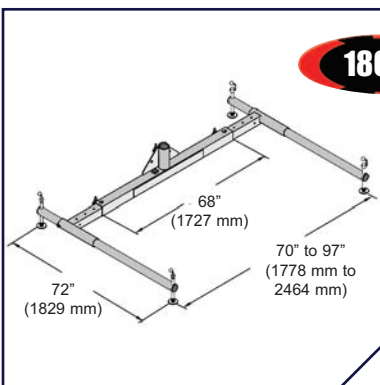

**18008**

**Advanced 3 Piece Expandable Base for Max. 48" Offset**

Price:	Part #	Description
	18008	Advanced 3 Pc Expandable Base for Max. 48" Offset

Weight: 92 lbs (41.8 Kg)

## Portable Bases (continued)

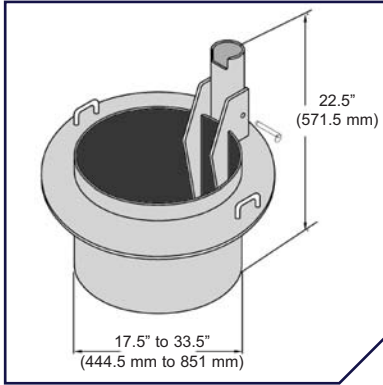

**Manhole Collars:** Designed for applications involving frequent setups over similarly sized access openings. Simply slip collar into sewer manhole, tank hatch or other openings. Lightweight, powder-coated aluminum construction for portability. Available on request in anodized finish for additional corrosion and tank contamination resistance. Comes with PVC sleeve liner. **Pt # 12994 shown.**

Price	Part #	Description
<input type="checkbox"/>	<b>10501</b>	<b>17.5" Manhole Collar:</b> For use on manways 18" - 20" in diameter.
<input type="checkbox"/>	<b>10520</b>	<b>19.5" Manhole Collar:</b> For use on manways 20" - 22" in diameter.
<input type="checkbox"/>	<b>10457</b>	<b>21.5" Manhole Collar:</b> For use on manways 22" - 24" in diameter.
<input type="checkbox"/>	<b>10163</b>	<b>23.5" Manhole Collar:</b> For use on manways 24" - 26" in diameter.
<input type="checkbox"/>	<b>10633</b>	<b>25.5" Manhole Collar:</b> For use on manways 26" - 28" in diameter.
<input type="checkbox"/>	<b>10632</b>	<b>27.5" Manhole Collar:</b> For use on manways 28" - 30" in diameter.
<input type="checkbox"/>	<b>10546</b>	<b>29.5" Manhole Collar:</b> For use on manways 30" - 32" in diameter.
<input type="checkbox"/>	<b>12994</b>	<b>33.5" Manhole Collar:</b> For use on manholes 34" - 36" in diameter.

**Custom sizes & shapes available. Please call for more information.**

Weight: 35 - 60 lbs (16 - 27 Kg)

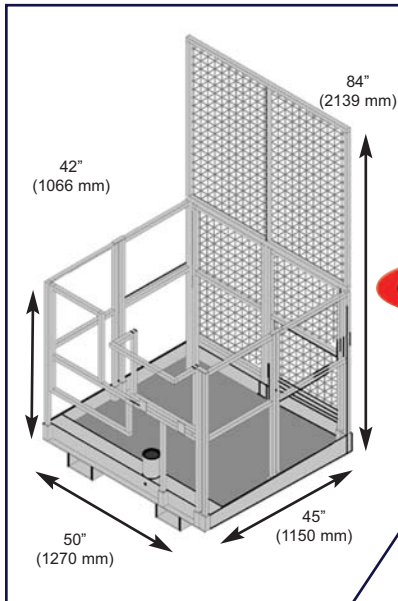

**10568**

**UCL Forklift Basket:** Designed to convert your forklift truck into a versatile work platform, confined space safety and fall-arrest system. By adding various accessories to the forklift basket a wide variety of confined space entry/retrieval and fall-arrest situations can be handled with ease. Lightweight modular aluminum construction and tool-less assembly makes set-up, transport and storage convenient and efficient. Durable powder-coated finish with anti-slip finish on walking surfaces. Includes spring-loaded gate.

Price:	Part #	Description
<input type="checkbox"/>	10568	UCL Forklift Mount Base with Powder Coated Aluminum

Weight: 215 lbs (98 Kg)

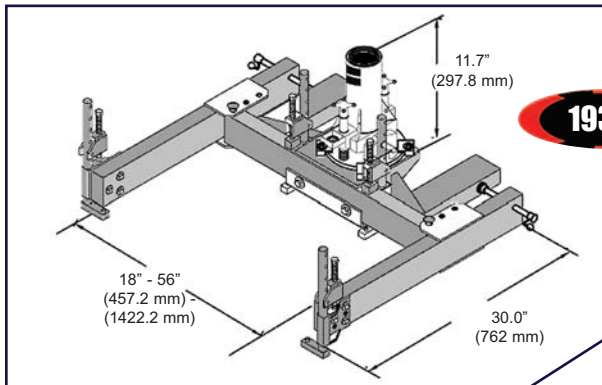

**19377**

**UCL External Tank Collar Assembly:** Comes with Adjustable Sleeve Assembly (pt:# 11232). Used on manways with a flange structure that the unit may be secured onto. This collar can clamp onto 6" max thick flange.

Price:	Part #	Description
<input type="checkbox"/>	19377	UCL External Tank Collar Assembly with Adjustable Sleeve

Weight: 82 lbs (37.3 Kg)

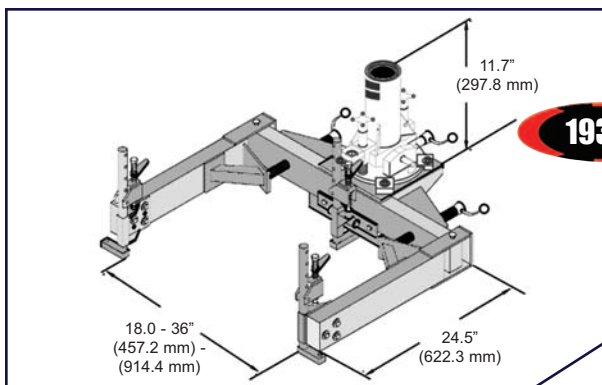

**19378**

**UCL Internal Adjustable Tank Collar:** Comes with Adjustable Sleeve Assembly (pt:# 11232). Used on manways with a structure that the unit may be secured onto. This collar may be used with sleeve assemblies and masts or for vertical entries.

Price:	Part #	Description
<input type="checkbox"/>	19378	UCL Internal Adjustable Tank Collar with Adjustable Sleeve

Weight: 61 lbs (27.7 Kg)

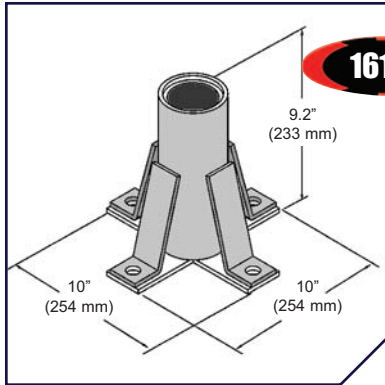

**16190**

**UCL Advanced Floor Mount Sleeve (Mild Steel):** Zinc-plated mild steel construction. Mounts to horizontal concrete or steel structure. Comes with PVC sleeve liner.

Price:	Part #	Description
	16190	UCL Advanced Floor Mount Sleeve, CS - 500 Zinc Plated
	18347	UCL Advanced Floor Mount Sleeve, 304 Stainless Steel Finish
	18503	UCL Advanced Floor Mount Sleeve, Hot-Dip Galvanized

Weight: 13 lbs (5.9 Kg)

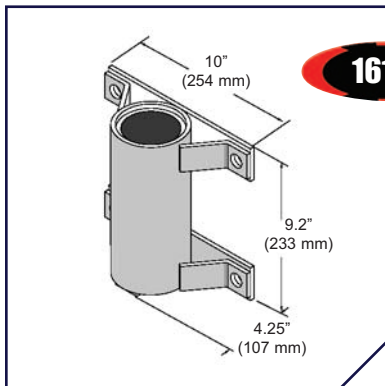

**16191**

**UCL Advanced Wall Mount Sleeve (Mild Steel):** Zinc-plated mild steel construction. Compact design creates minimum intrusion into work space. Mounts to vertical concrete or steel structures. Comes with PVC sleeve liner.

Price:	Part #	Description
	16191	UCL Advanced Wall Mount Sleeve, CS - 500 Zinc Plated
	18348	UCL Advanced Wall Mount Sleeve, 304 Stainless Steel Finish
	18504	UCL Advanced Wall Mount Sleeve, Hot-Dip Galvanized

Weight: 12 lbs (5.5 Kg)

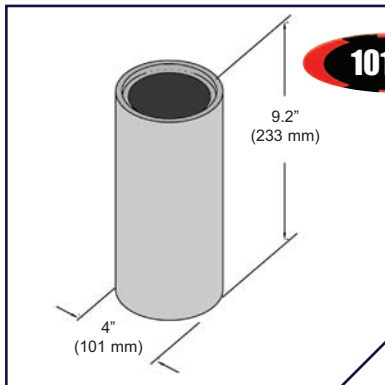

**10109**

**Zinc-Plated Mild Steel Core Mount Sleeve:** Designed for slip-in installation into 4"Ø core hole in concrete or in an existing steel structure. Comes with PVC sleeve liner.

Price:	Part #	Description
	10109	Zinc Plated Mild Steel Core Mount Sleeve
	10110	Stainless Steel Core Mount Sleeve

Weight: 8 lbs (3.6 Kg)

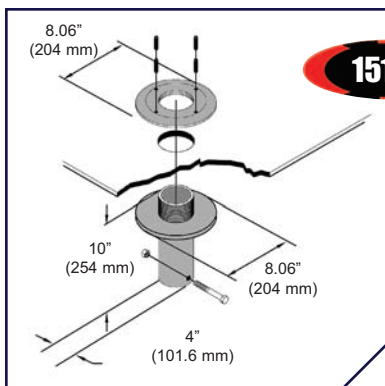

**15162**

**Deck Mount Sleeve:** Designed to slip into a 4"Ø hole in existing flooring. Flush mount design allows passage of traffic and eliminates trip hazards when not in use. Comes with all necessary hardware. Mounts to thicknesses from 1/4" to 2.0" max.

Price:	Part #	Description
	15162	UCL Deck Mount Sleeve, Zinc-Plated
	15834	UCL 304 Stainless Steel Deck Mount Sleeve
	17245	UCL 316 Stainless Steel Deck Mount Sleeve

Weight: 17 lbs (7.7 Kg)



## Fixed Bases (continued)

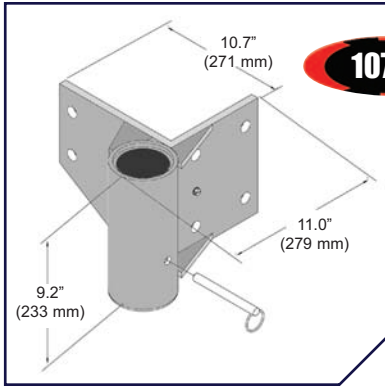

**10768**

**External 90 Degree Corner Mount Sleeve:** Zinc plated mild steel construction. Compact design creates minimum intrusion into work space. Mounts to vertical concrete or steel structure. Comes with PVC sleeve liner.

Price	Part #	Description
	10768	External 90 Degree Corner Mount Sleeve

Weight: 21 lbs (9.5 Kg)

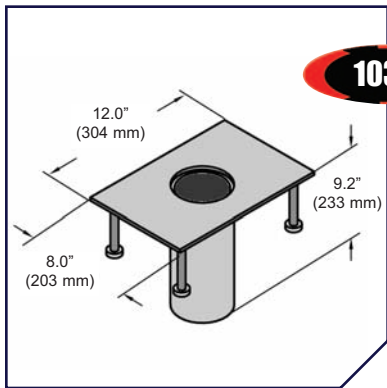

**10311**

**Flush Floor Mount Sleeve, Fresh Concrete (Mild Steel):** Comes with cast-in-place concrete anchors for new construction or renovation. Flush mount design allows passage of traffic and eliminates trip hazards when not in use. Comes with PVC sleeve liner.

Price:	Part #	Description
	10311	Flush Floor Mounted Sleeve (Mild Steel)
	12828	Flush Floor Mounted Sleeve (Stainless Steel)

Weight: 21 lbs (9.5 Kg)

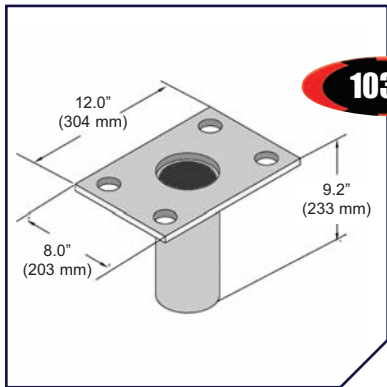

**10316**

**Flush Floor Mount Sleeve, Existing Concrete (Mild Steel):** Recessed fastener pockets allow for bolt-in installation into existing concrete or steel structure. Flush mount design allows passage of traffic and eliminates trip hazards when not in use. Comes with PVC sleeve liner.

Price:	Part #	Description
	10316	Flush Floor Mounted Sleeve (Mild Steel)
	12827	Flush Floor Mounted Sleeve (Stainless Steel)

Weight: 21 lbs (9.5 kg)

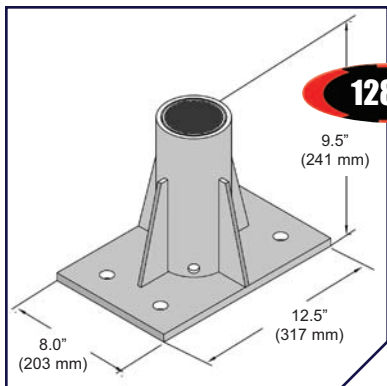

**12831**

**Center Mounted Floor Mount:** Mounts to existing concrete. Comes with PVC sleeve liner.

Price	Part #	Description
	12831	Center Mounted Floor Mount (Zinc Plated Mild Steel)
	16563	Center Mounted Floor Mount (Stainless Steel)

Weight: 13 lbs (5.9 kg)

## Fixed Base Accessories

**10552**



**Sleeve Cap:** Plastic construction with S.S. screw.

Price: Part # Description

10552 Sleeve Cap: Plastic construction with S.S. screw.

10553 Sleeve Cap: Stainless Steel construction with S.S. screw.

Weight: 0.4 lbs (0.2 kg)

**10826**

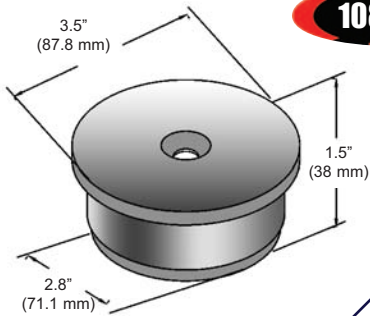

**Sleeve Cap:** Heavy-duty, Zinc-plated, mild steel construction.

Price: Part # Description

10826 Sleeve Cap: Heavy Duty, zinc-plated, mild steel construction.

Shipping Weight: 1.2 lbs (.54 Kg)

10827 Sleeve Cap: Heavy Duty, stainless steel construction.

Weight: 0.8 lbs (0.36 Kg)

## Carrying Bags

**13329**



Price: Part # Description

13329 Carrying Bag for One Piece Masts (#18382 & #18385)

13330 Carrying Bag for One Piece Masts (#18383, #18384, #18386 & #18387)

13564 Carrying Bag for #18001 Upper Davit & #18002 Lower Mast Extension.

13565 Carrying Bag for Three Piece Base (#18005)

15096 Carrying Bag for #18001 Upper Davit & #18003 Lower Mast Extension.

**13565**



# Ladder Hangers & Accessories

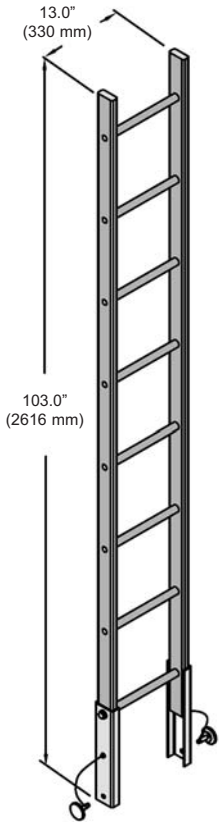

**18507**

**Eight Foot Ladder Section:** Comes with connector channels and positive pin locks. This ladder can be connected to additional ladders for a maximum length of 32'. Please refer to spec sheets for more information.

Price	Part #	Description
	18507	Eight Foot Ladder Section

Weight: 19.6 lbs (8.9 kg)

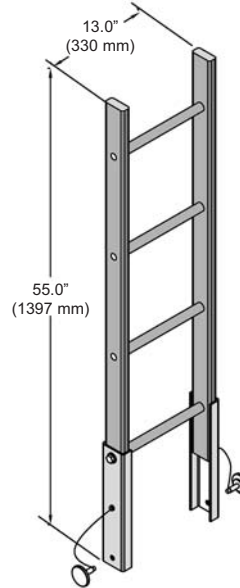

**18508**

**Four Foot Ladder Section:** Comes with connector channels and positive pin locks. This ladder can be connected to additional ladders for a maximum length of 32'. Please refer to spec sheets for more information.

Price	Part #	Description
	18508	Four Foot Ladder Section

Weight: 11 lbs (5.1 kg)

**UCL Advanced Non-Adjustable Ladder Hanger:** Designed to allow use of ladder sections with various base, sleeve and mast options. Installs over mast/extension. Mild steel construction for a durable finish.

Price	Part #	Description
	18505	UCL Advanced Non-Adjustable Ladder Hanger

Weight: 19 lbs (8.6 kg)

**18505**

**18506**

**UCL Advanced Adjustable Ladder Hanger:** Designed to install over mast extension in a UCL Mast System, and provide a bracket for mounting a UCL Portable Ladder System. The Advanced Adjustable Ladder sleeve allows for the adjustment of the location of the ladder relative to the mast assembly to accommodate various setups and to clear obstacles.

Price	Part #	Description
	18506	UCL Advanced Adjustable Ladder Hanger

Shipping Weight: 29 lbs (13.1 kg)

# Carts & Accessories



**18270**

**UCL Advanced Five Piece Equipment Cart:** Transport the UCL Advanced Five Piece System with maximum ease over smooth or rough terrain.

Price: Part # Description  
 18270 UCL 5 Piece Equipment Cart for Advanced Series Upper Masts.

Weight: 40 lbs (8.9 kg)

13814 Dust Cover for UCL 5 Piece Equipment Cart

Weight: 2 lbs (0.9 kg)

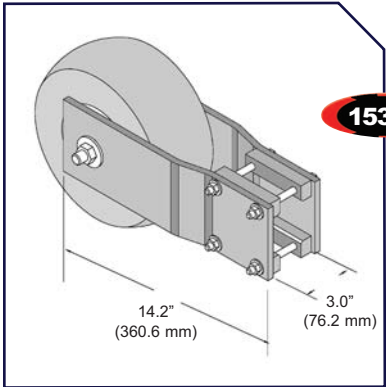

**15313**

**Wheel Kit for the UCL Three Piece Bases**

Price: Part # Description  
 15313 UCL Wheel Kit for the UCL 4 & 5 Piece Bases.

Weight: 30 lbs (13.6 kg)

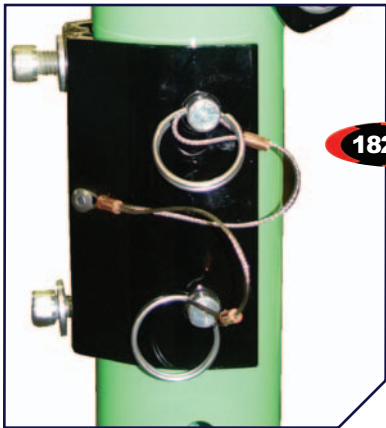

**18270**

**UCL Advanced Series Winch Mount Bracket:**

Designed to mount UCL Basic and Digital Winches and self retracting lifelines. Adapter plates are available to fit other manufacturers winch and self retracting lifeline models. However, please note that in addition to our adapter you may need the mounting bracket provided by the winch/SRL manufacturer. Please call for more information.

Price: Part # Description  
 16824 UCL Advanced Series Winch Mount Bracket

Weight: 1.6 lbs (0.7 kg)

**\* Other manufacturer's Winch/SRL brackets are available. Please refer to UCL Digital Winch/SRL brochures for more information.**

Distributed by:



**USA:** 1-800-328-6146  
**Canada:** 1-800-387-7484  
**Asia:** +852 2992 0381  
**Northern Europe:** +44 (0) 1928 57 1324  
**Europe, Middle East, Africa:** +33 (0) 497 10 00 10  
**Australia, New Zealand:** 1800 245 002  
 Or visit [www.capitalsafety.com](http://www.capitalsafety.com)



Manufactured by:  
**Unique Concepts Ltd.**  
 Unit 1 - 1500 King Edward Street  
 Winnipeg, Manitoba, Canada  
 R3H 0R5  
**Phone:** 204-694-7432  
**Toll Free:** 1-800-455-9673  
**Fax:** 204-694-7612  
**E-mail:** [qcm1@mts.net](mailto:qcm1@mts.net)