



Unique Door/Window Jamb Anchor Installs in Seconds, Providing a Fast, Simple and Safe Tie-Off Point for your Fall Arrest System.

- Fits door or window sizes ranging from 21-1/2" to 51-1/2" in width for complete jobsite flexibility.
- Non-penetrating design ensures no damage to structure.
- The anchor is simply compressed between the vertical sides of the door or window.
- Fast and easy installation with built-in adjustment knob - no tools or drilling are required.
- Lightweight and extremely portable design weighs only 14 lbs. for easy transport, storage and use.
- Meets OSHA requirements for fall arrest rated anchorages.



DOOR/WINDOW JAMB ANCHOR



Non-Penetrating Design For complete peace-of-mind, this door/window jamb anchor is designed to install without compromising the structure in any way. There is no drilling or welding required, you simply compress the device between the vertical sides of the door or window and tighten.

Fast, Simple and Safe Tie-Off Point This anchor installs quickly and efficiently in three easy steps. First, remove the locking pin. Second, you adjust the anchor to fit inside the desired opening. Finally, you use the built-in "coarse adjustment knob" to tighten and lock the device into place. Complete installation takes only seconds, and you have a safe, fall arrest rated anchor point to attach your shock absorbing lanyard or self retracting lifeline.

Lightweight and Portable Design This extremely portable and lightweight anchor weighs only 14 lbs. For complete jobsite flexibility, it can be easily moved from one location to another, installed, removed and stored. The portability and ease-of-use increases worker productivity and satisfaction. Typical applications for this anchor include residential and commercial construction, rooftops with door entrances, elevator shafts, wall openings, emergency egress and rescue and more.



Door/Window Jamb Anchor Model:

2100080: Door/Window Jamb Anchor, adjustable for openings ranging from 21-1/2" to 51-1/2"

Specifications:

Material: Aluminum and zinc plated steel **Size:** 56.36" long x 7.12" wide x 2.25" thick **Weight:** 14 lbs. **Capacity:** One user, 310 lbs. **Strength:** 3,600 lbs. **Standards:** Meets OSHA requirements for fall arrest rated anchorages

Installation Steps:

Complete installation takes only seconds, and you have a safe, fall arrest rated anchor point.

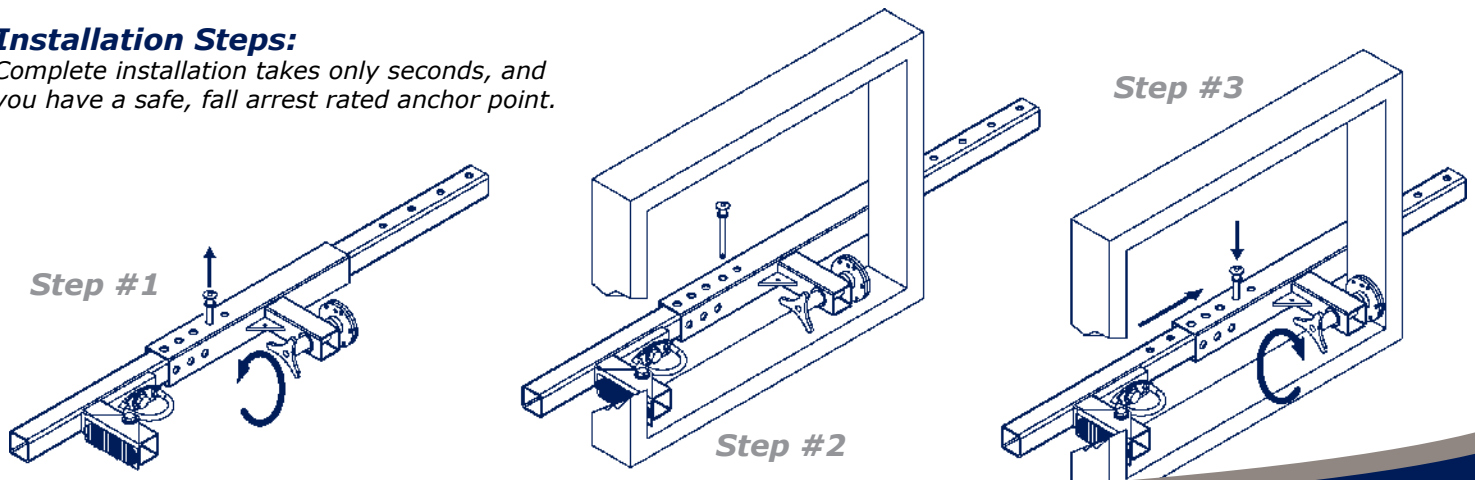

Capital Safety

USA : 800.328.6146 • Canada : 800.387.7484 • Asia : + 852 2992 0381 • Australia/New Zealand : 800 245 002
 Europe, Middle East, Africa : +33 (0) 497 10 00 10 • Northern Europe : +44 (0) 1928 571324
www.capitalsafety.com • info@capitalsafety.com