

# Amaline - Circulating Pump

Industry

Water

Waste Water

Energy

Building Services

Mining

## Applications:

- Recirculation of activated sludge
- Pumping of storm, river and surface water
- Creation of flow in impounded water

Further information: [www.ksb.com](http://www.ksb.com)

[www.ksbusa.com](http://www.ksbusa.com)



# Amaline - Circulating Pump

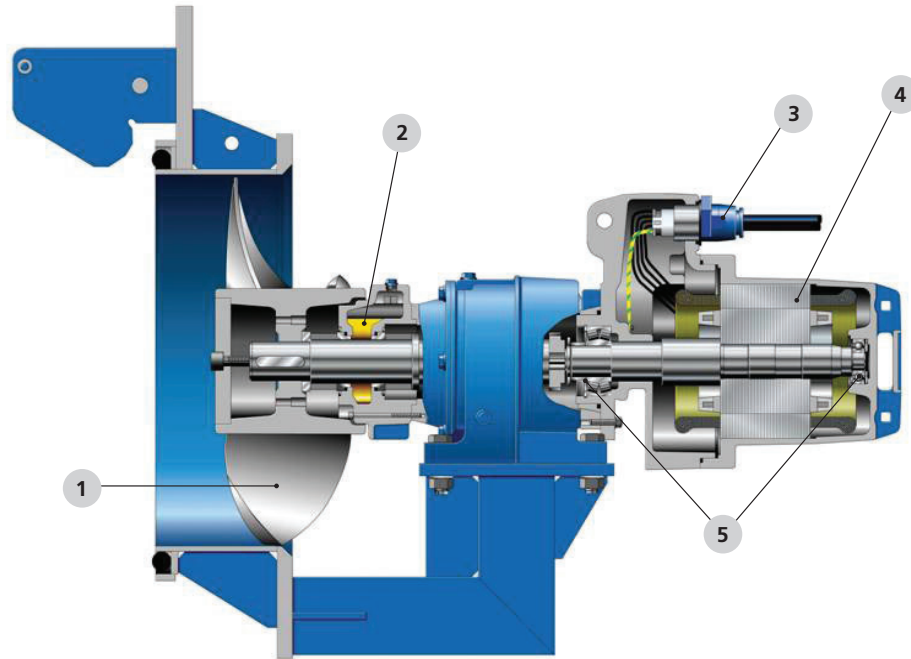

**1 Highly reliable**

Hydraulic system with ECB Propeller

**2 Long service life**

Tandem mechanical seals with silicon carbide faces, independent of the direction of rotation

**3 Completely protected**

An absolutely water-tight, resin-embedded cable entry protects the motor against moisture.

**4 Efficient**

Protection of motor with temperature sensors

**5 Service friendly**

Pre-lubricated antifriction bearings

### Technical data

Max. Speed:	1750 rpm
Max. Power:	20 hp
Nom. propeller diameter:	12" - 32"
Max. flow rate:	22,600 gpm
Max. temperature:	104 °F

