

MASKAFLEX : ELASTOMERIC TIRE TYPE



Features: Superior designed and manufactured “X-Tork” tire. Bonded and thermally stabilized rubber with double-woven textile cords & multiple cables in toe that allow the element to seat perfectly and contribute to element stability & flange grip. Ridged extremity & inner sidewalls designed for enhanced grip of the flanges.

How to order COMPLETE COUPLING: Example: MX 120; MX 120 = Complete MASKAFLEX part number.

FLANGE Example: MXF 120 = MASKAFLEX flange part number.

Element Material Example: P120 = MASKAFLEX element part number (tire)

A complete Maskaflex coupling corresponds to (2) flanges and (1) element. Specify the bore size required to order the appropriate QD bushing with it.

Dimensions

Complete Coupling Part No	List price w/o Bushing Complete Coupling	Mult. Sym.	Bush. Size	~ Max. Bore	Type	Dimensions (inches)							Weight (lbs)		
						A	B	C	D	E	F	G	Complete	Flange	Tire
MX 50**	114.00	CPL14	JA	1 1/4	1	5 1/4	3 7/8	3 23/32	3 17/32	7/8	*	1 17/32	4.7	2.1	.5
MX 60	151.00	CPL14	SH	1 5/8	1	6 1/2	4 23/32	4 1/2	4 9/32	1 9/32	*	1 25/32	8.0	3.5	1.0
MX 70	201.00	CPL14	SDS	1 15/16	1	7 3/8	4 17/32	4 5/16	4 1/8	1 1/2	*	1 1/2	10.7	4.7	1.3
MX 80	265.00	CPL14	SK	2 1/2	1	8 3/8	5 13/16	5 17/32	5 1/4	1 1/2	*	1 1/2	15.5	6.9	1.7
MX 90	335.00	CPL14	SK	2 1/2	1	9 1/4	5 7/8	5 9/16	5 5/16	1 17/32	*	1 9/16	22.0	10.0	2.0
MX 100	411.00	CPL14	SF	2 3/4	1	10	6 1/8	5 25/32	5 15/32	1 23/32	*	1 15/32	32.0	15.0	2.0
MX 110	457.00	CPL14	SF	2 3/4	1	11	5 7/8	5 1/2	5 3/16	1 9/16	*	1 3/16	46.0	21.5	3.0
MX 120	529.00	CPL14	E	3 7/16	1	12 3/8	7 1/4	6 7/8	6 1/2	1 3/4	*	1 1/4	59.8	28.0	3.8
MX 140	918.00	CPL14	F	3 15/16	2	14 1/8	9 1/2	9 1/16	8 5/8	2 1/16	*	1 3/8	132.5	64.0	4.5
MX 160	1352.00	CPL14	J	4	2	16 5/8	11 1/2	10 7/8	10 3/8	2 11/16	*	1 3/8	208.7	100.0	8.7
MX 200	2043.00	CPL14	J	4	2	20	11 3/4	11 5/16	10 13/16	3 5/16	*	1 13/16	366.0	174.0	18.0

~ Maximum bore with keyseat

* Shaft ends although normally “G” distance apart can project beyond the bushings and be closer together. If this occurs, allow space between shaft ends for endfloat and misalignment.

** The MX50 coupling can only be outside-outside mount.

Parts

Flange			Tire		
Flange Part No.	List Price	Mult. Sym.	Tire Part No.	List Price	Mult. Sym.
MXF 50	37.00	CPL14	P50	40.00	CPL15
MXF 60	52.00	CPL14	P60	47.00	CPL15
MXF 70	68.00	CPL14	P70	65.00	CPL15
MXF 80	89.00	CPL14	P80	87.00	CPL15
MXF 90	121.00	CPL14	P90	93.00	CPL15
MXF 100	155.00	CPL14	P100	101.00	CPL15
MXF 110	171.00	CPL14	P110	115.00	CPL15
MXF 120	200.00	CPL14	P120	129.00	CPL15
MXF 140	354.00	CPL14	P140	210.00	CPL15
MXF 160	550.00	CPL14	P160	252.00	CPL15
MXF 200	790.00	CPL14	P200	463.00	CPL15

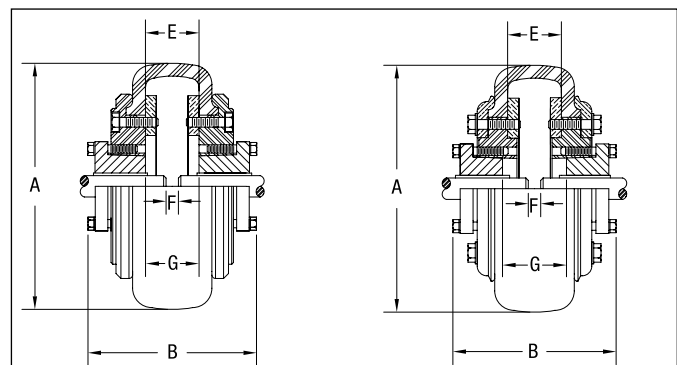

MX 50 TO MX 120

MX 140 TO MX 200