

Slip-on

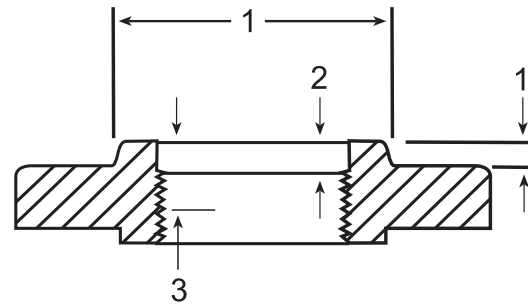

Threaded

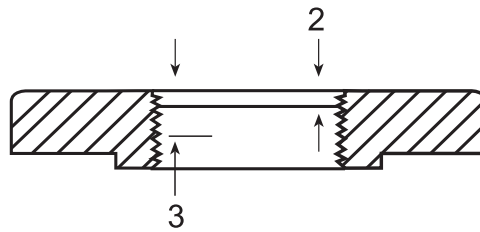

Blind

FLANGES

Pipe Size	Smallest Size of Reducing Outlet Requiring Hub Flanges	
1	Group I	1/2
1 1/4		1/2
1 1/2		1/2
2		1
2 1/2		1 1/4
3	Group II	1 1/4
3 1/2		1 1/2
4		1 1/2
5		1 1/2
6		2 1/2
8	Group III	3
10		3 1/2
12		3 1/2
14		3 1/2
16		4
18	4	
20	4	
24	4	

Note:

1. The hub dimensions shall be at least as large as those of the standard flanges of the size to which the reduction is being made, except flanges reducing to a size smaller than those Groups I, II and III may be made from blind flanges.
2. Class 150 flanges do not have a counter bore. Class 300 and higher pressure flanges will have depth of counter bore (q) of 0.25 in. for NPS 2 and smaller tapping and 0.38 in. for NPS 2 1/2 and larger. The diameter (Q) of counter bore is the same as that given in the tables of threaded flanges for the corresponding tapping.
3. Minimum length of effective threads shall be at least equal to dimension (T) of the corresponding pressure class threaded flange as shown in tables, but do not necessarily extend to the face of the flange. For thread of threaded flanges, see page 158.