

Fig. 28M - Offset Hanger and Restrainer for CPVC Plastic Pipe and IPS Pipe



Size Range — 3/4" thru 1-1/4" pipe

Material — Carbon Steel, Electro-Galvanized

Function — Designed to be used as a hanger and restrainer for CPVC piping where the "stand-off" design will ease installation by eliminating the need for wood blocking

Features —

- Flared edge design protects CPVC pipe from any rough or abrasive surfaces
- Unique snap-on design holds pipe firmly in place and allows retrofit type of installation
- The "Stand-Off" design eliminates the need for wood block extension
- Can be installed on horizontal or vertical piping regardless of mounting surface orientation
- Attaches easily to wood structure with two hex head self-threading screws furnished with product
- Installs easily using rechargeable electrical driver with 5/16" extension socket eliminating impact tool damage to pipe
- Attaches easily to steel, minimum 18 gauge with (2) 1/4" x 1" tek type self drilling tapping screws
- cULus Listed as a hanger and a restrainer for fire sprinkler piping

Approvals — Underwriters' Laboratory Listed in the USA (UL) and Canada (cUL) to support automatic fire sprinkler systems. May be installed into wood using fasteners screws. Meets and exceeds the requirements of NFPA 13, 13R and 13D. Fig. 28M satisfies the UL vertical restraint requirements where needed.

Order By — Figure number and pipe size

PATENT PENDING

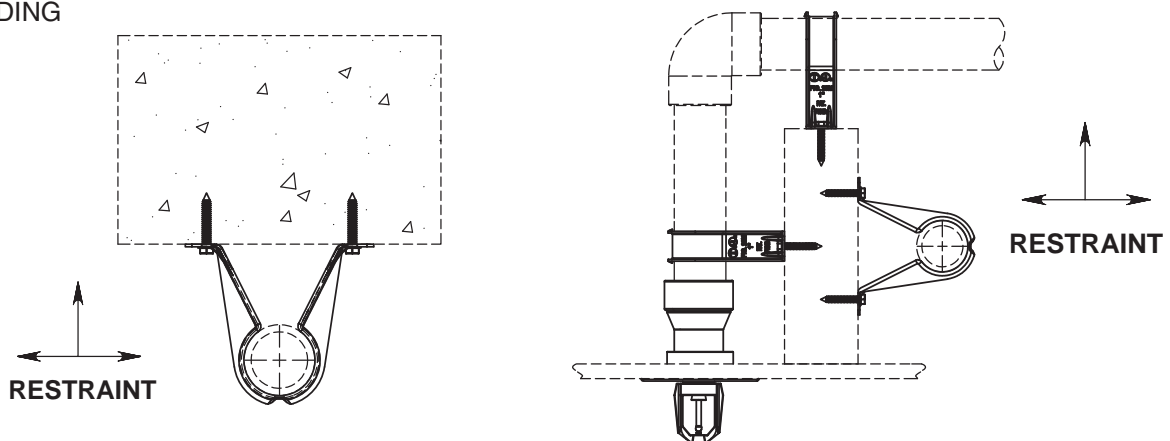
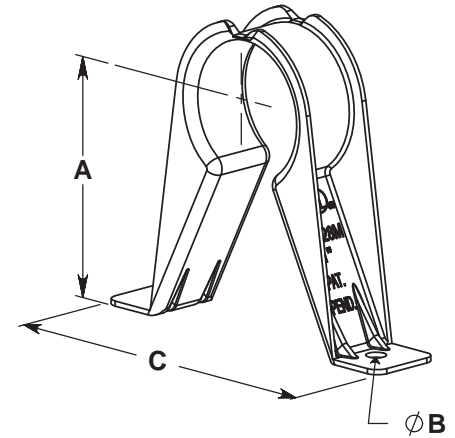

Fig. 28M

Dimensions • Weights					
Pipe Size	A	B	C	Max. Spacing required per NFPA 13 for CPVC plastic pipe	Approx Wt./100
3/4	2	3/16	3-1/2	5'-6"	9
1	2-1/8	3/16	3-1/2	6'-0"	12
1-1/4	2-5/16	3/16	3-1/2	6'-6"	13