

Maintenance-Free Circulators Cast Iron Wet Rotor/NRF

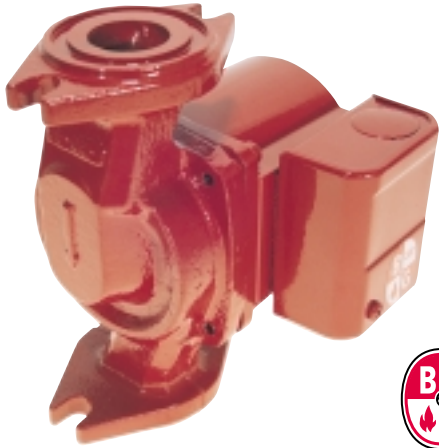

Maximum working pressure. 150 psi (10 bar)
 Maximum operating temperature
 NRF-22 & NRF-9F/LW. 240°F (115°C)
 NRF-33. 225°F (107°C)
 See page 8 for flanges.

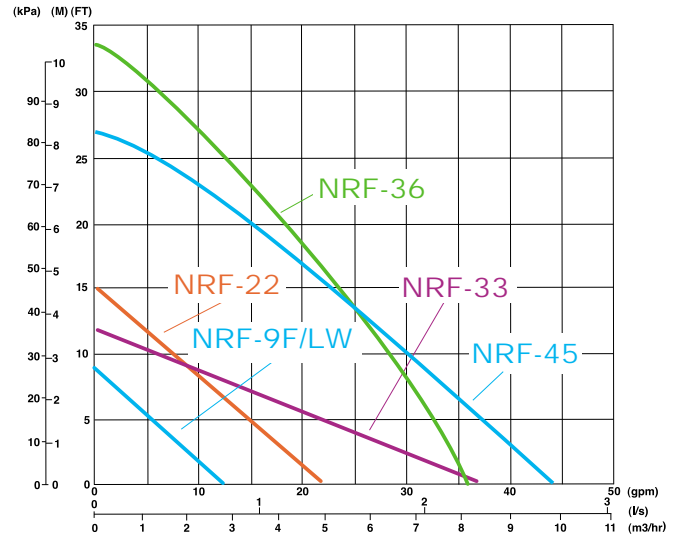

Cast Iron Circulators

Model Number	Part Number	Flange Size Inches - NPT	Dimensions Inches (mm)			Standard 60Hz Motor Characteristics*					Approx. Shpg. Wt. lbs (Kg)
			A	B	C	Watts	Ø	Voltage	F.L. Amps	RPM	
NRF-22	103251	3/4, 1, 1-1/4, 1-1/2	6-3/8 (162)	5-9/16 (141)	4-7/8 (124)	92	1	115	0.80	2940	9.3 (4.2)
NRF-9F/LW	103267	3/4, 1, 1-1/4, 1-1/2	6-3/8 (162)	5-9/16 (141)	4-7/8 (124)	41			0.40	2800	9.3 (4.2)
NRF-33	103350	3/4, 1, 1-1/4, 1-1/2	6-1/8 (156)	6-3/16 (157)	5-1/8 (130)	125			1.10	2950	10.4 (4.7)
NRF-36**	103400	3/4, 1, 1-1/4, 1-1/2	6-3/8 (162)	6-7/8 (175)	5-3/4 (146)	260			2.30	3200	12.9 (5.6)
NRF-45**	103404	1, 1-1/4, 1-1/2	8-1/2 (216)	7-3/8 (187)	5-7/8 (149)	260			2.30	3200	14.4 (6.5)

NEW

*230/60/1 motor available upon request. Impedance protected
 Dimensions are approximate and subject to change. Consult factory for certified dimensions.
 ** NRF-36, NRF-45 are three-speed circulators, high speed performance curve shown.

Dimensions

Dimensions are approximate and subject to change. Contact factory for certified dimensions.

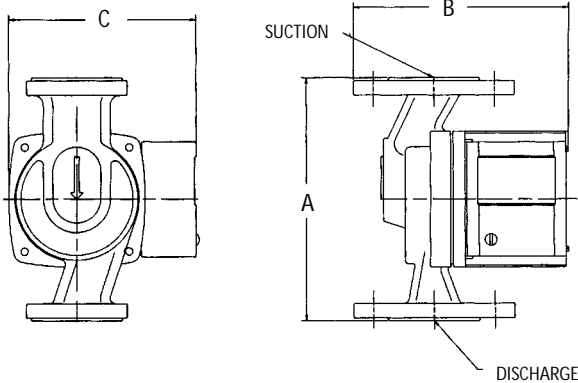

1 DuraGlide™ Bearing System (blue areas in cutaway illustration) incorporates several components working together to eliminate seasonal freeze-up

2 Powerful motor provides years of trouble-free operation

3 One-piece, high-nickel stainless steel stator can isolate the stator from system fluid and maintains precision bearing alignment for longer bearing life

4 Carbon bearings, diamond-like ceramic shaft and generous clearances are more resistant to lime, chloride and oxide build-up

5 Face plate and rotor sleeve feature corrosion resistant stainless steel construction for longer life

6 Self-cleaning particle shield protects the shaft and bearings from system start-up debris

7 Stabilized, heat resistant, non-ferrous impeller, its closed design improves operating efficiency

