

Tube Axial Inline Fans

Models TDI & TBI-CA Level 3 with Cast Aluminum Propeller

Direct & Belt Drive • Clean Air or Fume Exhaust • Emergency Smoke



BUILDING VALUE IN AIR.

 **GREENHECK**
Building Value in Air.

March
2007

Tube Axial Inline Fans

Greenheck's tube axial fans are the ideal choice for ducted or unducted installations. Tube axials are not only economical to purchase, but the inherent "straight-through airflow" provides high mechanical efficiencies resulting in low operating costs.

Greenheck's versatile tube axial design can be used in most commercial and industrial applications. Typical applications include:

- General exhaust, supply or return air
- Industrial space ventilation
- Fume hood exhaust
- Smoke removal
- Paint booth exhaust

TDI Features:

- Direct drive construction
- Sizes from 18 to 48 inch propeller diameters
- CFM Range: 3,800 to 48,400
- Static Pressure: Up to 0.875 inches wg
- Temperature: Up to 110° F (43° C)

TBI-CA Features:

- Spark resistant construction
- Belt drive with motor and drives out of airstream
- Sizes from 18 to 60 inch propeller diameters
- CFM Range: 1,700 to 78,000
- Static Pressure: Up to 1.25 inches wg
- Temperature: Up to 180° F (82° C)

Both the TDI and TBI-CA models feature a continuously welded housing for airtight construction and integral punched inlet and outlet flanges.

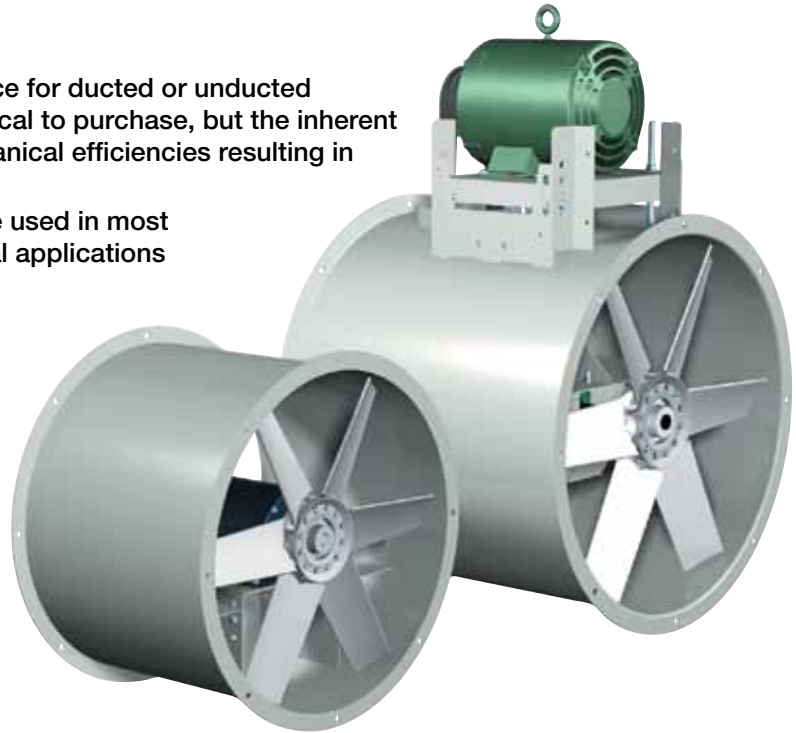

Cast Aluminum Propellers

The TDI and TBI-CA use heavy duty, cast aluminum airfoil propellers that are designed to meet a large range capacity and pressure requirements.

All TDI and TBI-CA propellers are dynamically balanced to assure vibration free operation. All propellers are tightly secured to the fan or motor shaft with taper lock bushings.



Leading Edge Support

All Greenheck products are supported by the industry's best product literature, electronic media, and Computer Aided Product Selection program (CAPS). You'll also find extensive product and Installation and Operation and Maintenance Manuals (IOM) information on the Internet.

And, of course, you can always count on the personal service and expertise of our national and international representative organization. To locate your nearest Greenheck representative call 715-359-6171 or visit our web site at www.greenheck.com



Quick Delivery and Quick Build Programs

Greenheck's Quick Delivery (QD) and Quick Build (QB) Programs ensure rapid response time with your needs dictating manufacturing time. Use CAPS or visit www.greenheck.com/quick to determine what programs are available for these products.

AMCA Licensed Air Data / UL Listing

All sizes and configurations of the TDI and TBI-CA have AMCA licensed air data. In addition, the entire offering is available with a UL and cUL 705 listing for electrical. The following decals will ensure that your fan will operate safely and at the performance levels specified.

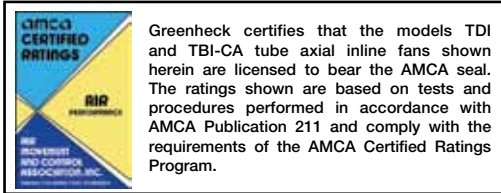

Electrostatic Powder Paint

Powder coatings offer a uniform, durable, and high quality finish. Powder coating is a one-coat process applied over a phosphatized surface that generally meets or exceeds the corrosion resistance of a comparable wet paint.

Greenheck offers a number of in-house coatings applied via “electrostatic powder”. The standard coating, Permator™, is excellent for indoor or outdoor applications and is resistant to many common chemicals. Consult Greenheck’s Product Application Guide FA/110-04R, Performance Coatings for Ventilation Products for a complete listing of coatings and a relative resistance chart.

Maintenance / Serviceable

The TBI-CA incorporates the following value added features that allow for quick and easy field service.

- Bearing lubrication is performed through extended grease fittings located on the outside of the fan housing.
- An adjustable motor base is provided for tightening the fan belts.
- Propellers are easily removed with the use of taper lock bushings.

For best access to the propeller and internal fan components for field service, see the “Easy Access Construction” option in the Accessories section.



Complete Assembly and Testing

The TDI and TBI-CA are completely assembled and tested before shipment. Our inspectors check that the fan operates with minimal vibration and is electrically safe for field operation.

Compact Size

Both the TDI and TBI-CA are designed for compact spaces. Keeping size to a minimum is important when fitting into a tight space, moving around corners, or through doorways.

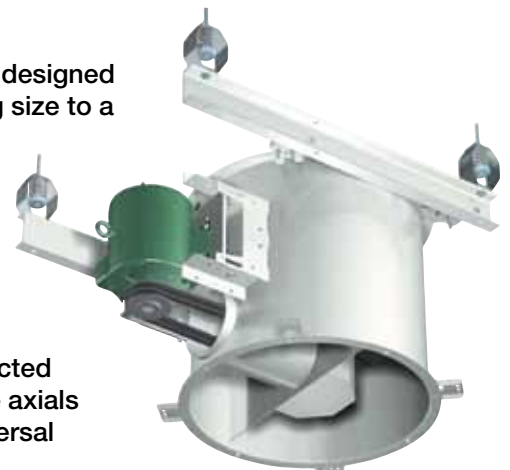

Easy to Install and Operate

Flexibility in a motor’s location is important for easier access and can determine where the unit will fit. Last minute design changes or unexpected obstacles during installation are no longer a problem. Greenheck’s tube axials include integral connection flanges and are available with optional Universal Mounting hardware.

Belt Guard

Belt guards provide protection from rotating pulleys and belts. Belt guards meet OSHA standards.

Motor Cover

Weatherproof motor cover shields the motor and drive components from dust, dirt, and moisture for indoor/outdoor installations. Motor covers meet OSHA standards.

Inspection Section

Inspection sections are an easily removable length of duct and are recommended to improve serviceability. Inspection sections are available with a full diameter removable access panel or an inspection door allowing quick inspections inside the ductwork.

Inspection Door

Bolted or hinged, inspection door provides access through the fan tube for cleaning or inspection of the propeller, bearings, and drives.

Inlet and Outlet Guards

Removable inlet and outlet guards provide protection for personnel and equipment in ducted or non-ducted installations. Inlet and outlet guards meet OSHA standards.

Inlet Bell with Inlet Guard

Inlet bells minimize entry losses in non-ducted applications by providing more uniform airflow into the propeller blades. Inlet bell with inlet guard meets OSHA standards.

Companion Flanges

Companion inlet and outlet flanges with prepunched holes are available for all fan sizes.

Shaft Seal

Shaft seals prohibit leakage of air into the bearing compartment of the fan.

Extended Wiring (Direct Drive)

Motor wiring is extended to the exterior of the fan casing for easy installation of the unit in the field.

OPTIONS

Easy Access Construction

The Easy Access option is highly recommended to provide inspection, cleaning, and service of internal fan components. This option allows for the removal of the fan shaft and bearings through the housing without removing the fan from the duct. For service or removal of the propeller, the inspection section with removable access panel is recommended.

Aluminum Construction

The TBI-CA and TDI are available in all aluminum construction. Consult the factory for details.

Mounting Rails

Mounting rails are required for horizontal mounting of TBI-CA belt driven fans when the motor is to be located in the 3 or 9 o'clock position or for all vertical applications. Universal mounting brackets are required.

Isolators

Both base mount or hanging isolators are available in either neoprene or spring mounts. The isolators are furnished in sets of four and are sized to match the weight of each fan.

Special Coatings

Special coatings are available for protective purposes. Coatings are applied before assembly so that each manufactured component is coated inside and out. Painting the exterior a specified color for appearance is also an option. Consult Greenheck's Product Application Guide FA/110-04R, Performance Coatings for Ventilation Products for a complete listing of coatings and a relative resistance chart.

Disconnect Switches

Toggle type and heavy duty disconnect switches are available for positive electrical shut-off and safety in servicing fans. Switches can be factory mounted or shipped loose for field mounting.

- NEMA-1 – General purpose
- NEMA-3R – Rainproof
- NEMA-4 – Watertight
- NEMA-7 & 9 – Class 1 and Class 2 hazardous locations.

Greenheck will not factory mount NEMA-7 & 9 disconnect switches.

Universal Mounting Brackets

Universal Mounting brackets include all hardware necessary to position the fan horizontally or vertically either for base mounting or ceiling hanging.



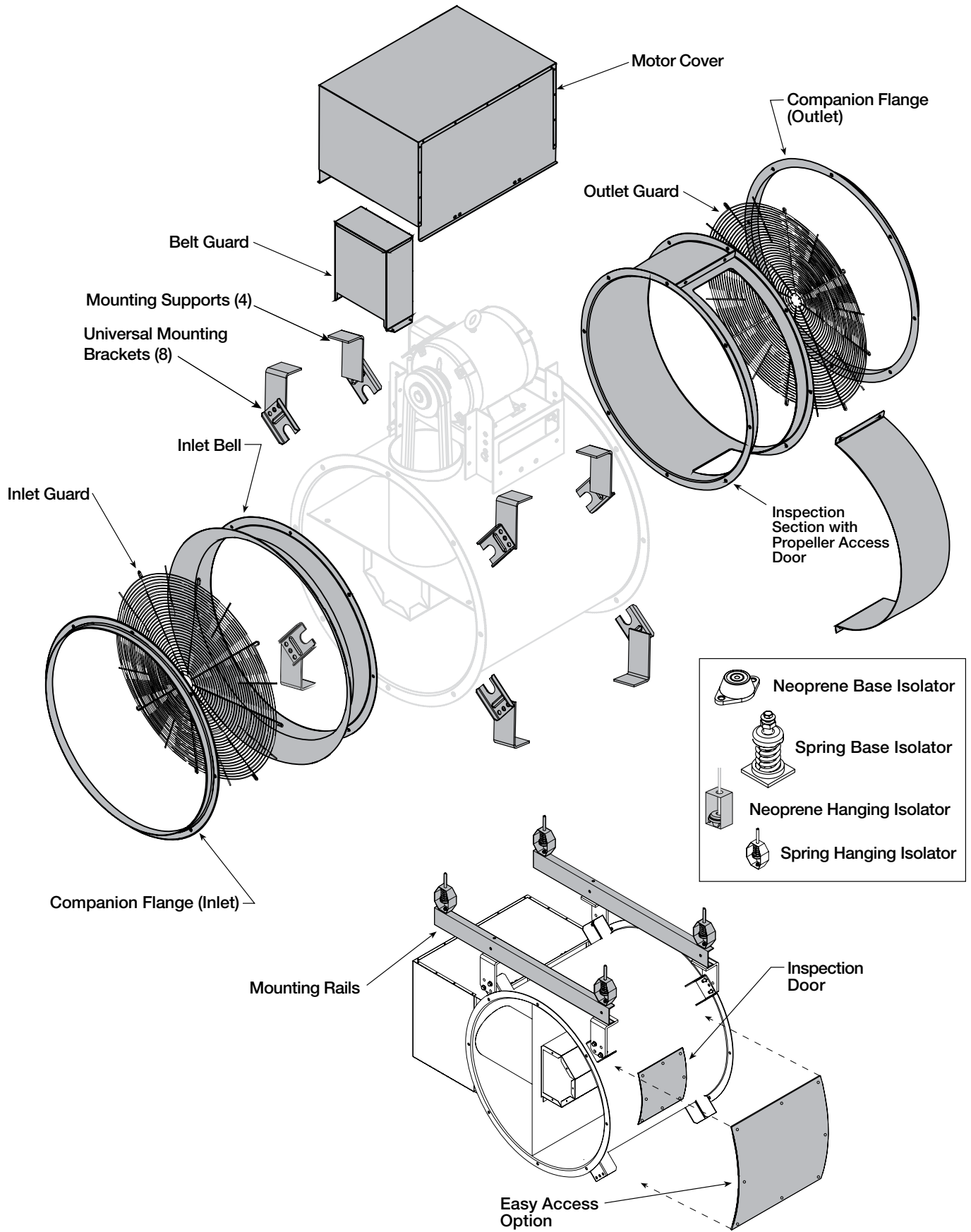

Housing

Housings are continuously welded to prevent air leakage. All steel constructed units are provided with Permatector™ coating.

Inlet & Outlet Flanges

Integral inlet and outlet flanges with mounting holes are provided for an airtight ductwork connection.

Bearings (Belt Drive)

Bearings are air handling quality, grease lubricated, pillow block type. Bearings are selected with a basic rating fatigue life (L10) in excess of 80,000 hours at each fan's maximum operating speed when mounted in a horizontal configuration.

Belt & Bearing Tube

Belts, bearings, and drives are protected from the airstream by a heavy gauge steel belt tube and bearing cover.

Adjustable Motor Bases (Belt Drive)

Rigid structural steel motor bases are welded to the fan housing and include heavy duty adjustment screws for belt tensioning.

Extended Lube Lines

Extended lube lines with grease fittings allow bearing lubrication from the fan exterior.

Drives (Belt Drive)

Greenheck offers either constant or adjustable speed drives for fan speed adjustments. Belts are static free and oil resistant.

Motors

NEMA base-mounted motors are standard. Motors are available in open drip proof, totally enclosed, or explosion proof.

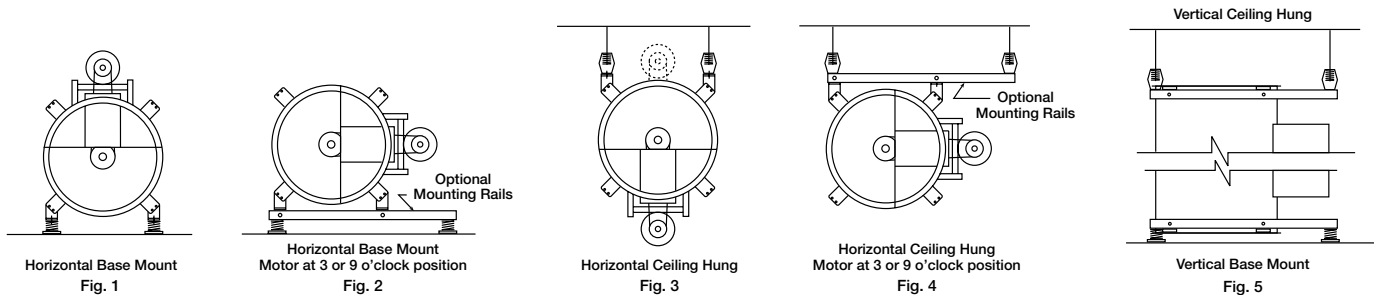

Horizontal and Vertical Mounting Configurations (Brackets Optional)

All tube axial fans can be mounted horizontally or vertically. For ease of installation, eight mounting brackets are welded on each fan. These eight brackets along with standard mounting supports provide for Greenheck's universal mounting system.

Fig. 1 Horizontal Base Mount

Each fan is shipped as standard in this arrangement. Motor at 12 o'clock is standard.

Fig. 2 Horizontal Base Mount with motor at 3 or 9 o'clock

A set of optional mounting rails are required for this installation. This is the base mounting position required with the easy access option.

Fig. 3 Horizontal Ceiling Hung

In this installation the supports can be positioned for mounting the motor at either 6 or 12 o'clock.

Fig. 4 Horizontal Ceiling Hung with motor at 3 or 9 o'clock

A set of optional mounting rails are required for this installation.

Fig. 5 Vertical Mount

All TDI and TBI-CA fans can be mounted vertically (ceiling hung or base mount) for either upward or downward airflow. Optional mounting rails are recommended for belt driven fans.

NOTE: All fans are shown with optional mounting brackets and vibration isolators. See the appropriate submittal drawings or installation manual for complete dimensional data.

MODEL NUMBER CODE

The model number system is designed to completely identify the fan.

TDI - 3 - 24 - 0609 - A 20		TBI - CA - 3H 24 - 20	
Tube Axial Inline D - Direct Drive	Motor Horsepower 4 = 1/4 20 = 2 3 = 1/3 30 = 3 5 = 1/2 50 = 5 7 = 3/4 75 = 7 1/2 10 = 1 100 = 10 15 = 1 1/2 150 = 15 200 = 20	Tube Axial Inline B - Belt Drive	Motor Horsepower 4 = 1/4 20 = 2 3 = 1/3 30 = 3 5 = 1/2 50 = 5 7 = 3/4 75 = 7 1/2 10 = 1 100 = 10 15 = 1 1/2 150 = 15 200 = 20
Level	Fan RPM M = 3600 B = 1200 A = 1800 C = 900	Cast Aluminum Prop	Fan Size 18, 20, 24, 30, 36, 42, 48, 54, 60
Fan Size 18, 20, 24, 30, 36, 42, 48	Blade Pitch	Level of Construction/ Propeller Type 3L - Low Pressure 3M - Medium Pressure 3H - High Pressure	Number of Blades 03, 04, 06

TDI-18 Direct Drive

Shown with Optional Brackets

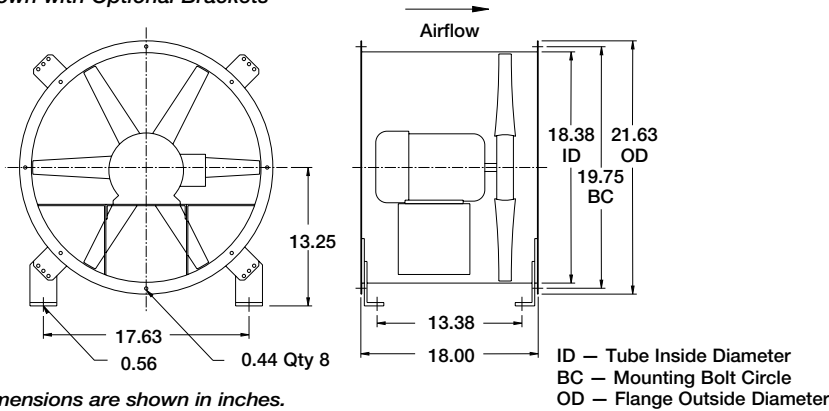

Dimensions are shown in inches.

Specifications

Max frpm = 1725
 Max Motor Frame Size = 145T
 Fan Tube Gauge = 12 ga.
 Approx. Weight (LM) = 70 lbs.

Outlet Velocity (fpm) = cfm / 1.84 ft²
 Tip Speed = frpm x 4.71

TDI Performance Data - Level 3

Model Number	Motor HP	Fan RPM	Max BHP	* L _{wj} A	** dBA	Static Pressure in Inches WG / CFM									
						0.000	0.125	0.250	0.375	0.500	.6250	0.750	0.875	1.000	
						CFM	CFM	CFM	CFM	CFM	CFM	CFM	CFM	CFM	
18-0438	1/4	1140	0.30	92	81	3859	3369								
18-0630	1/4	1140	0.27	81	70	3566	3230								
18-0610	1/4	1725	0.27	91	80	2631	2509	2363	2175						
18-0412	1/4	1725	0.28	88	77	3050	2854	2606							
18-0316	1/4	1725	0.27	88	77	3416	3117	2809							
18-0613	1/3	1725	0.34	93	82	3111	2972	2822	2643						
18-0417	1/3	1725	0.36	89	78	3666	3439	3191	2888						
18-0323	1/3	1725	0.37	91	80	4148	3847	3522	3119	2603					
18-0620	1/2	1725	0.59	94	83	4074	3922	3754	3558	3323	3014				
18-0423	1/2	1725	0.57	92	81	4356	4099	3834	3521						
18-0329	1/2	1725	0.57	92	81	4757	4461	4115	3707	3179					
18-0626	3/4	1725	0.82	95	84	4847	4677	4483	4254	3987	3651	3132			
18-0338	3/4	1725	0.85	94	83	5452	5110	4734	4266	3420					
18-0435	3/4	1725	0.90	96	85	5568	5296	4968	4572						
18-0634	1	1725	1.14	97	86	5873	5657	5417	5112	4748	4371				

Performance certified is for installation type B: free inlet, ducted outlet. Power rating (bhp) does not include transmission losses. Performance ratings do not include the effects of appurtenances (accessories). The AMCA Certified Ratings Seal applies to air performance ratings only.

* Sound power values listed are at 0.125 inches pressure wg for each rpm.

** dBA sound pressure values are weighted with 11.5 dB attenuation for each octave band at 5 feet. Listed sound pressure value is for each rpm at 0.125 inches wg.

Shown with Optional Brackets

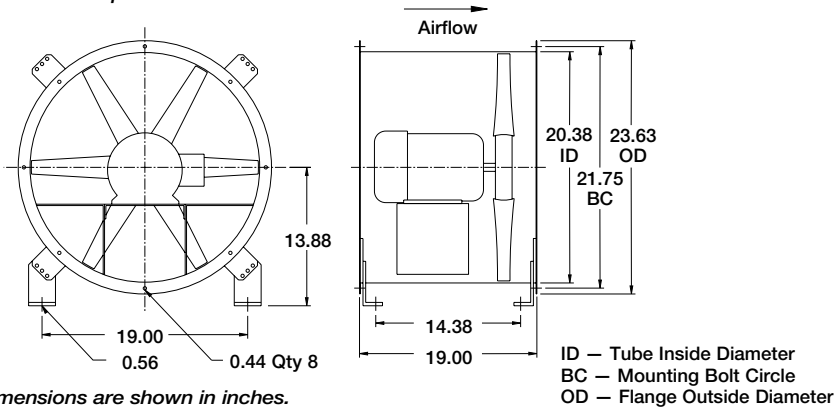

Specifications

Max frpm = 1725
 Max Motor Frame Size = 145T
 Fan Tube Gauge = 12 ga.
 Approx. Weight (LM) = 80 lbs.

Outlet Velocity (fpm) = $\text{cfm} / 2.26 \text{ ft}^2$
 Tip Speed = $\text{frpm} \times 5.24$

TDI Performance Data - Level 3

Model Number	Motor HP	Fan RPM	Max BHP	* L _{wj} A	** dBA	Static Pressure in Inches WG / CFM								
						0.000	0.125	0.250	0.375	0.500	.6250	0.750	0.875	1.000
						CFM	CFM	CFM	CFM	CFM	CFM	CFM	CFM	CFM
20-0620	1/4	1140	0.28	82	71	3862	3538	3133	2583					
20-0427	1/4	1140	0.28	81	70	4359	3885							
20-0432	1/3	1140	0.36	82	71	4783	4285							
20-0331	1/4	1140	0.28	79	68	4435	3850	3044						
20-0335	1/3	1140	0.34	80	69	4758	4103	3279						
20-0605	1/4	1725	0.29	88	77	2890	2723	2565						
20-0408	1/4	1725	0.27	87	76	3450	3217	2931						
20-0312	1/3	1725	0.32	88	77	4112	3774	3387	2978					
20-0608	1/3	1725	0.39	92	81	3504	3345	3181	2985	2720				
20-0315	1/3	1725	0.40	88	77	4586	4218	3846	3443					
20-0613	1/2	1725	0.56	91	80	4401	4227	4032	3827	3594				
20-0417	1/2	1725	0.58	89	78	5070	4795	4488	4153	3784	3307			
20-0322	3/4	1725	0.62	90	79	5616	5265	4862	4458	3958				
20-0618	3/4	1725	0.85	92	81	5482	5290	5070	4814	4592	4295	3916		
20-0424	3/4	1725	0.85	91	80	6221	5875	5562	5209	4831	4338			
20-0328	3/4	1725	0.86	92	81	6395	6020	5625	5207					
20-0622	1	1725	1.09	93	82	6075	5856	5630	5384	5115	4837	4543	4127	
20-0335	1	1725	1.17	94	83	7201	6786	6335	5883	5346				
20-0429	1	1725	1.14	93	82	7018	6682	6354	5988	5594	5156			

Performance certified is for installation type B: free inlet, ducted outlet. Power rating (bhp) does not include transmission losses. Performance ratings do not include the effects of appurtenances (accessories). The AMCA Certified Ratings Seal applies to air performance ratings only.

* Sound power values listed are at 0.125 inches pressure wg for each rpm.

** dBA sound pressure values are weighted with 11.5 dB attenuation for each octave band at 5 feet. Listed sound pressure value is for each rpm at 0.125 inches wg.

Shown with Optional Brackets

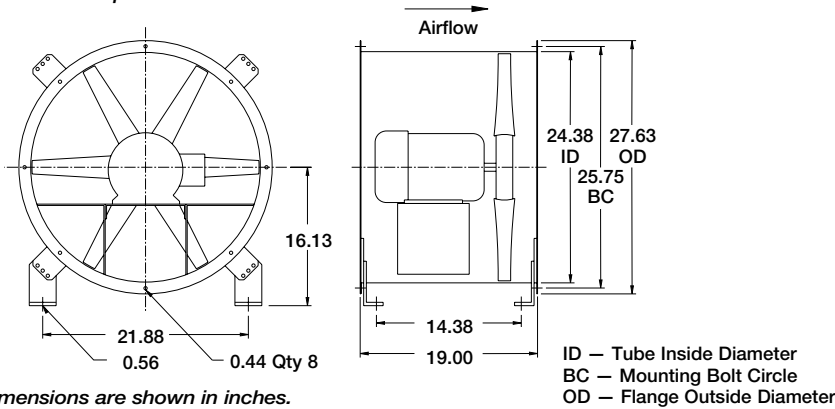

Dimensions are shown in inches.

Specifications

Max fpm = 1725

Max Motor Frame Size = 184T

Fan Tube Gauge = 12 ga.

Approx. Weight (LM) = 90 lbs.

Outlet Velocity (fpm) = cfm / 3.24 ft²

Tip Speed = fpm x 6.28

TDI Performance Data - Level 3

Model Number	Motor HP	Fan RPM	Max BHP	* L _{wjA}	** dBA	Static Pressure in Inches WG / CFM									
						0.000	0.125	0.250	0.375	0.500	.6250	0.750	0.875	1.000	
						CFM	CFM	CFM	CFM	CFM	CFM	CFM	CFM	CFM	
24-0624	1/4	860	0.29	78	67	5439	4712	3741							
24-0335	1/4	860	0.29	77	66	5682	4376								
24-0630	1/3	860	0.39	77	66	6215	5391	4313							
24-0609	1/4	1140	0.27	83	72	4337	3930	3430	2679						
24-0412	1/4	1140	0.25	81	70	5058	4452								
24-0612	1/3	1140	0.35	83	72	5104	4665	4166	3480						
24-0417	1/3	1140	0.34	82	71	5708	5085	4304	3333						
24-0426	1/2	1140	0.58	85	74	7123	6441	5598	4481						
24-0621	1/2	1140	0.59	85	74	6734	6250	5670	4983	4116					
24-0435	1/2	1140	0.87	87	76	8181	7391								
24-0630	3/4	1140	0.90	88	77	8239	7654	6981	6186	5261					
24-0635	1	1140	1.15	89	78	9028	8398	7667	6762						
24-0604	1/2	1725	0.60	94	83	4902	4629	4358	4054	3697	3276				
24-0407	1/2	1725	0.56	93	82	5760	5391	4977	4531	3971	3282				
24-0609	1	1725	0.93	97	86	6563	6306	6033	5736	5407	5001	4521	3958		
24-0316	1	1725	0.91	93	82	7960	7484	6945	6375	5758	5026				
24-0612	1 1/2	1725	1.22	95	84	7724	7444	7147	6834	6510	6147	5740	5170	4396	
24-0417	1	1725	1.20	95	84	8638	8255	7830	7349	6833	6281	5657	4776		
24-0321	1 1/2	1725	1.23	95	84	9059	8585	8035	7464	6832	6093	5130			
24-0618	1 1/2	1725	1.70	97	86	9237	8960	8669	8344	7981	7578	7162	6679		
24-0423	1 1/2	1725	1.65	97	86	9994	9561	9103	8592	8050	7469	6806	6065		
24-0328	1 1/2	1725	1.70	96	85	10293	9805	9263	8628	7858	7041				
24-0335	2	1725	2.38	97	86	11398	10804	10198	9533	8796					
24-0624	2	1725	2.38	99	88	10910	10589	10258	9873	9461	9030	8571	8077	7529	
24-0429	2	1725	2.27	98	87	11304	10872	10404	9878	9272	8618	7872			
24-0631	3	1725	3.24	99	88	12599	12226	11837	11396	10922	10415	9919	9380		

Performance certified is for installation type B: free inlet, ducted outlet. Power rating (bhp) does not include transmission losses. Performance ratings do not include the effects of appurtenances (accessories). The AMCA Certified Ratings Seal applies to air performance ratings only.

* Sound power values listed are at 0.125 inches pressure wg for each rpm.

** dBA sound pressure values are weighted with 11.5 dB attenuation for each octave band at 5 feet. Listed sound pressure value is for each rpm at 0.125 inches wg.

Shown with Optional Brackets

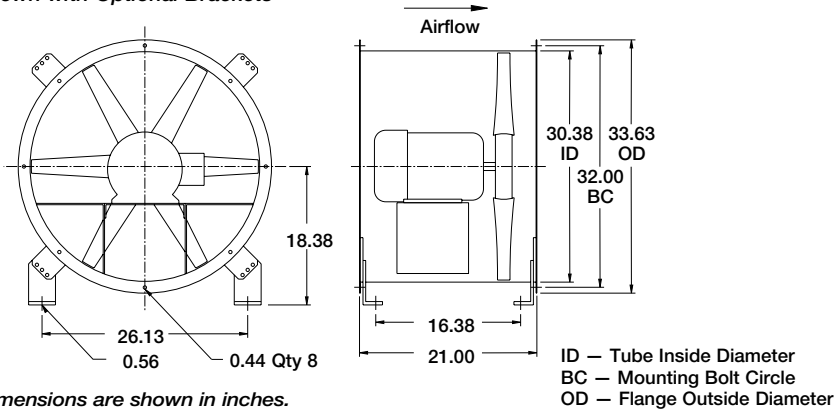

Dimensions are shown in inches.

Specifications

Max frpm = 1725
 Max Motor Frame Size = 184T
 Fan Tube Gauge = 12 ga.
 Approx. Weight (LM) = 115 lbs.

Outlet Velocity (fpm) = cfm / 5.034 ft²
 Tip Speed = frpm x 7.854

TDI Performance Data - Level 3

Model Number	Motor HP	Fan RPM	Max BHP	* L _{wi} A	** dBA	Static Pressure in Inches WG / CFM								
						0.000	0.125	0.250	0.375	0.500	.6250	0.750	0.875	1.000
						CFM	CFM	CFM	CFM	CFM	CFM	CFM	CFM	CFM
30-0315	1/4	860	0.26	79	68	7431	5847							
30-0620	1/2	860	0.60	84	73	9497	8465	7235						
30-0425	1/2	860	0.57	81	70	9775	8319	6341						
30-0434	3/4	860	0.87	85	74	11039	9478	7375						
30-0627	3/4	860	0.88	83	72	11138	9990	8625						
30-0633	1	860	1.18	91	80	12478	11175	9659						
30-0413	3/4	1140	0.65	88	77	9515	8571	7493						
30-0617	1	1140	1.17	90	79	11549	10822	10020	9136	8035				
30-0422	1	1140	1.16	89	78	12227	11282	10119	8787	6865				
30-0624	1 1/2	1140	1.72	92	81	13665	12891	12093	11094	9992	8297			
30-0430	1 1/2	1140	1.71	91	80	14046	12939	11664	10090					
30-0438	2	1140	2.31	93	82	15208	14058	12679	10900					
30-0630	2	1140	2.39	93	82	15599	14762	13793	12695					
30-0603	1 1/2	1725	1.29	100	89	9276	8824	8348	7842	7308	6770	6152		
30-0405	1 1/2	1725	1.26	97	86	10686	10087	9433	8690	7856	6991	5979		
30-0606	1 1/2	1725	1.74	100	89	11218	10773	10323	9865	9327	8751	8131		
30-0409	1 1/2	1725	1.64	97	86	12313	11661	10984	10310	9562	8747	7796		
30-0413	2	1725	2.24	98	87	14398	13746	13143	12477	11762	11031	10149		
30-0623	5	1725	5.63	102	91	20365	19868	19371	18848	18314	17772	17137		
30-0428	5	1725	5.42	102	91	20633	19895	19174	18478	17717	16836	15818		

Performance certified is for installation type B: free inlet, ducted outlet. Power rating (bhp) does not include transmission losses. Performance ratings do not include the effects of appurtenances (accessories). The AMCA Certified Ratings Seal applies to air performance ratings only.

* Sound power values listed are at 0.125 inches pressure wg for each rpm.

** dBA sound pressure values are weighted with 11.5 dB attenuation for each octave band at 5 feet. Listed sound pressure value is for each rpm at 0.125 inches wg.

Shown with Optional Brackets

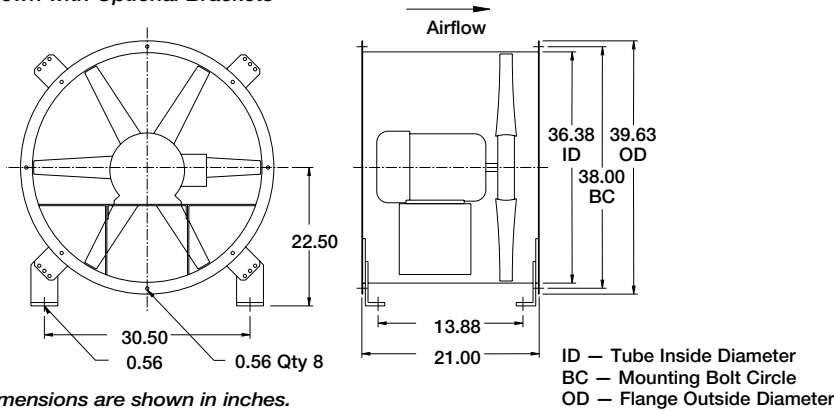

Specifications

Max fpm = 1725
Max Motor Frame Size = 215T
Fan Tube Gauge = 12 ga.
Approx. Weight (LM) = 185 lbs.

Outlet Velocity (fpm) = cfm / 7.22 ft²
Tip Speed = fpm x 9.42

TDI Performance Data - Level 3

Model Number	Motor HP	Fan RPM	Max BHP	* L _{wi} A	** dBA	Static Pressure in Inches WG / CFM									
						0.000	0.125	0.250	0.375	0.500	.6250	0.750	0.875	1.000	
						CFM	CFM	CFM	CFM	CFM	CFM	CFM	CFM	CFM	
36-0608	1/2	860	0.55	85	74	9463	8353	7018	5042						
36-0315	1/2	860	0.55	86	75	11859	9904								
36-0612	3/4	860	0.83	86	75	12153	11027	9694	7919						
36-0418	3/4	860	0.87	87	76	13830	12199	10259	7219						
36-0422	1	860	1.12	81	70	15206	13578	11487	8153						
36-0617	1	860	1.17	88	77	14367	13170	11818	10122						
36-0624	1 1/2	860	1.78	89	78	17047	15583	14038	12221						
36-0630	2	860	2.36	90	79	19687	18150	16422	14499						
36-0639	3	860	3.29	92	81	21839	20153	18236	16331						
36-0305	1/2	1140	0.60	93	82	10659	9269	7550							
36-0604	1	1140	0.94	96	85	10130	9242	8274	6953	5864	4566				
36-0407	1	1140	0.91	94	83	12322	11117	9887	8391						
36-0608	1 1/2	1140	1.27	96	85	12544	11758	10848	9868	8664	7137				
36-0315	1 1/2	1140	1.27	93	82	15720	14245	12645	10654						
36-0610	1 1/2	1140	1.63	96	85	14760	13847	13022	12063	10919	9514				
36-0416	1 1/2	1140	1.67	95	84	16552	15502	14185	12784						
36-0615	2	1140	2.31	96	85	17568	16680	15760	14850	13692	12497				
36-0420	2	1140	2.31	97	86	19104	18001	16687	15178	13441					
36-0620	3	1140	3.28	97	86	20790	19922	18910	17857	16760	15414				
36-0426	3	1140	3.24	97	86	22069	20697	19257	17546	15713					
36-0440	5	1140	5.58	94	83	25645	24329	22782	20458						
36-0630	5	1140	5.50	99	88	26098	24952	23759	22477	21095	19620				
36-0403	2	1725	2.21	105	94	14857	14022	13203	12348	11445	10473	9430			
36-0305	2	1725	2.07	101	90	16128	15273	14308	13294	12138	10892	9527			
36-0407	3	1725	3.14	102	91	18645	17811	17054	16247	15436	14562	13609	12560	11284	
36-0310	3	1725	3.10	102	91	20132	19199	18309	17347	16265	15126	13896			
36-0610	5	1725	5.59	105	94	22335	21731	21128	20564	20020	19476	18830	18166	17450	
36-0416	5	1725	5.82	104	93	25047	24375	23703	22846	21984	21086	20183	19218	18235	
36-0615	7 1/2	1725	7.76	106	95	26583	25997	25410	24809	24200	23592	22992	22392	21642	
36-0420	7 1/2	1725	7.99	105	94	28907	28187	27467	26628	25768	24837	23854	22828	21769	
36-0620	10	1725	11.17	107	96	31458	30885	30312	29682	29006	28330	27640	26927	26213	
36-0426	10	1725	11.23	107	96	33394	32488	31582	30673	29765	28683	27576	26395	25196	

Performance certified is for installation type B: free inlet, ducted outlet. Power rating (bhp) does not include transmission losses. Performance ratings do not include the effects of appurtenances (accessories). The AMCA Certified Ratings Seal applies to air performance ratings only.

* Sound power values listed are at 0.125 inches pressure wg for each rpm.

** dBA sound pressure values are weighted with 11.5 dB attenuation for each octave band at 5 feet. Listed sound pressure value is for each rpm at 0.125 inches wg.

Shown with Optional Brackets

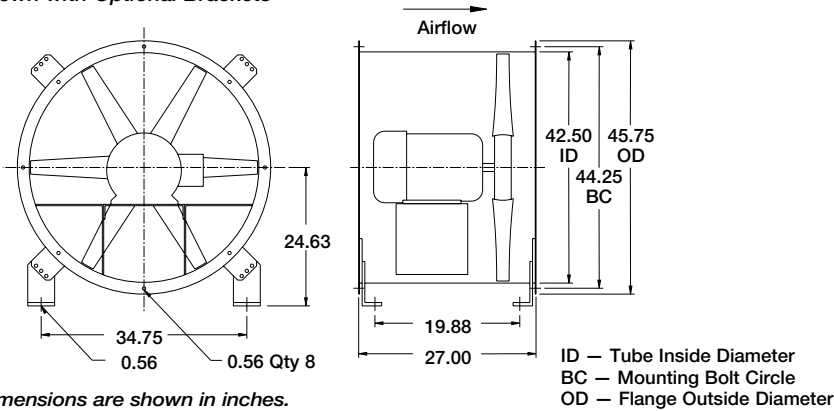

Dimensions are shown in inches.

Specifications

Max frpm = 1140
 Max Motor Frame Size = 256T
 Fan Tube Gauge = 10 ga.
 Approx. Weight (LM) = 275 lbs.

Outlet Velocity (fpm) = cfm / 9.85 ft²
 Tip Speed = frpm x 11.0

TDI Performance Data - Level 3

Model Number	Motor HP	Fan RPM	Max BHP	* L _{wj} A	** dBA	Static Pressure in Inches WG / CFM								
						0.000	0.125	0.250	0.375	0.500	.6250	0.750	0.875	1.000
						CFM	CFM	CFM	CFM	CFM	CFM	CFM	CFM	CFM
42-0324	3/4	680	0.85	83	72	17541	13432							
42-0615	3/4	680	0.83	84	73	15986	13840	11196						
42-0618	1	680	1.12	84	73	18212	16032	13284						
42-0626	1 1/2	680	1.71	87	76	21743	19270	16209						
42-0635	2	680	2.29	89	78	24214	21392	18361						
42-0608	1	860	1.16	91	80	16891	15362	13477	11251					
42-0413	1	860	1.14	89	78	18488	16261	13776	10185					
42-0317	1	860	1.15	88	77	19430	16619	12778						
42-0615	1 1/2	860	1.68	91	80	20217	18461	16721	14590					
42-0419	1 1/2	860	1.73	90	79	22102	19805	16942	13266					
42-0618	2	860	2.27	92	81	23033	21340	19528	17251					
42-0435	3	860	3.27	93	82	26845	24424	21300						
42-0625	3	860	3.29	93	82	27069	25358	23243	20840	17849				
42-0404	1 1/2	1140	1.23	97	86	17177	15575	13746	11646					
42-0306	1	1140	1.14	95	84	17935	15850	13562						
42-0604	1 1/2	1140	1.80	98	87	17841	16641	15217	13722	12295	10449	8516		
42-0310	1 1/2	1140	1.71	95	84	21390	19328	17039	14703					
42-0409	2	1140	1.95	97	86	21381	19730	18035	16167	13829				
42-0607	2	1140	2.40	99	88	21317	20102	18943	17505	15941	14243	12147	9888	
42-0412	2	1140	2.38	96	85	23775	21928	20083	18254	16219				
42-0315	3	1140	2.48	97	86	24877	22890	20701	18007	14581				
42-0415	3	1140	3.15	97	86	26376	24676	22972	21128	19066	15942			
42-0319	3	1140	3.15	97	86	27113	24974	22479	19735	16689				
42-0619	5	1140	5.61	100	89	31380	30126	28925	27557	25832	24268	22462	20051	
42-0626	7 1/2	1140	8.06	102	91	36452	35193	33632	32019	30422	28238			
42-0635	10	1140	10.78	104	93	40594	39128	37337	35584	34109	32102			

Performance certified is for installation type B: free inlet, ducted outlet. Power rating (bhp) does not include transmission losses. Performance ratings do not include the effects of appurtenances (accessories). The AMCA Certified Ratings Seal applies to air performance ratings only.

* Sound power values listed are at 0.125 inches pressure wg for each rpm.

** dBA sound pressure values are weighted with 11.5 dB attenuation for each octave band at 5 feet. Listed sound pressure value is for each rpm at 0.125 inches wg.

Shown with Optional Brackets

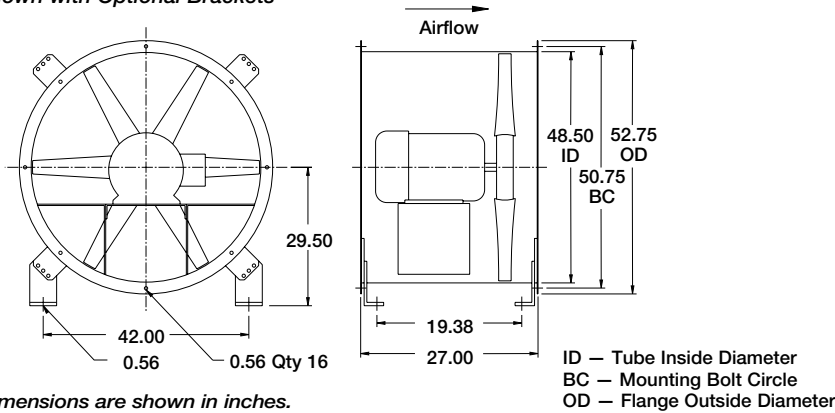

Dimensions are shown in inches.

Specifications

Max frpm = 1140
 Max Motor Frame Size = 256T
 Fan Tube Gauge = 10 ga.
 Approx. Weight (LM) = 330 lbs.

Outlet Velocity (fpm) = cfm / 12.8 ft²
 Tip Speed = frpm x 12.6

TDI Performance Data - Level 3

Model Number	Motor HP	Fan RPM	Max BHP	* L _{wj} A	** dBA	Static Pressure in Inches WG / CFM									
						0.000	0.125	0.250	0.375	0.500	.6250	0.750	0.875	1.000	
						CFM	CFM	CFM	CFM	CFM	CFM	CFM	CFM	CFM	
48-0411	3/4	680	0.89	89	78	20947	17152	12343							
48-0606	3/4	680	0.87	90	79	18275	15662	12455							
48-0423	1 1/2	680	1.80	89	78	26434	22075								
48-0616	1 1/2	680	1.74	93	82	25237	22604	19298							
48-0621	2	680	2.39	91	80	28874	26031								
48-0630	3	680	3.35	95	84	32194	28973	24774							
48-0602	1 1/2	860	1.22	95	84	18690	16575	14324	11631	8488					
48-0405	1	860	1.18	94	83	21341	18639	15543							
48-0606	1 1/2	860	1.75	97	86	23112	21046	18792	16256	12799					
48-0411	2	860	1.81	95	84	26492	23624	20343	16547	9693					
48-0321	3	860	2.46	94	83	29864	25530	21136							
48-0421	3	860	3.35	96	85	32407	29317	25977	21537						
48-0615	3	860	3.34	97	86	31373	29097	26673	24087	21187					
48-0435	5	860	5.66	99	88	36836	33230	28108							
48-0624	5	860	5.48	98	87	38105	35525	32712	29491	25851					
48-0403	2	1140	2.30	103	92	25778	23702	21612	19000	16446	13023	9248			
48-0306	2	1140	2.18	101	90	27105	24586	22052	18991	15249					
48-0603	3	1140	3.05	104	93	25786	24307	22935	21270	19383	17316	15103	12565		
48-0407	3	1140	3.29	103	92	30876	28590	26524	24107	21706	18446	15154			
48-0321	5	1140	5.72	104	93	39587	36088	33173	29959	26028	21724				
48-0331	7 1/2	1140	8.32	107	96	42346	39627	36755							
48-0616	7 1/2	1140	8.20	106	95	42310	40887	39311	37560	35776	33708	31482	28634	25505	
48-0423	7 1/2	1140	8.49	106	95	44316	42232	39334	36520	33579	30609				
48-0431	10	1140	11.01	107	96	47458	45050	42531	39920	36460	31971				
48-0621	10	1140	11.27	107	96	48407	46587	44918	43313	41348	38603				

Performance certified is for installation type B: free inlet, ducted outlet. Power rating (bhp) does not include transmission losses. Performance ratings do not include the effects of appurtenances (accessories). The AMCA Certified Ratings Seal applies to air performance ratings only.

* Sound power values listed are at 0.125 inches pressure wg for each rpm.

** dBA sound pressure values are weighted with 11.5 dB attenuation for each octave band at 5 feet. Listed sound pressure value is for each rpm at 0.125 inches wg.

Shown with Optional Brackets

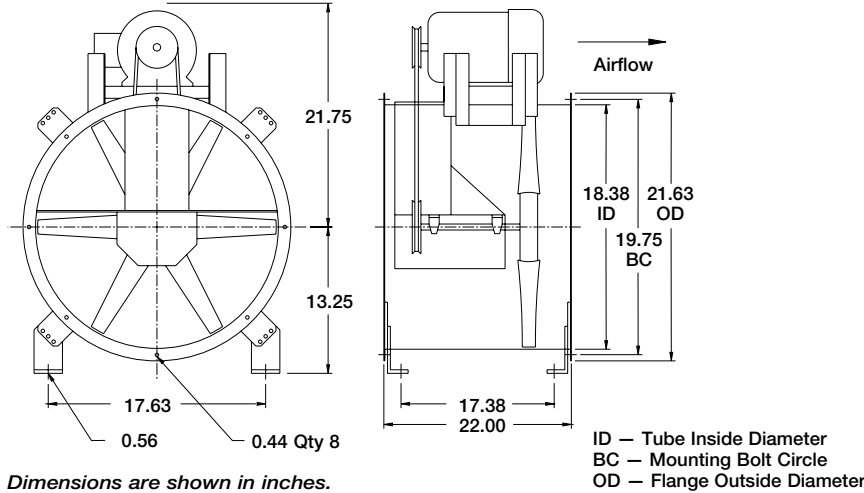

Dimensions are shown in inches.

Specifications

Max frpm = 2283
 Max Motor Frame Size = 145T
 Shaft Diameter = 1 in.
 Fan Tube Gauge = 12 ga.
 Approx. Weight (LMD) = 110 lbs.

Outlet Velocity (fpm) = cfm / 1.84 ft²
 Tip Speed = frpm x 4.71

TBI-CA Performance Data - Level 3

Model Number	Motor HP	Fan RPM	Max BHP	* L _{wj} A	** dBA	Static Pressure in Inches WG / CFM										
						0.000	0.125	0.250	0.375	0.500	.6250	0.750	0.875	1.000	1.125	1.250
						CFM	CFM	CFM	CFM	CFM	CFM	CFM	CFM	CFM	CFM	CFM
3L18-4	1/4	2050	0.25	87	76	2286	2109	1900	1591	1135						
3L18-4	1/4	2104	0.27	87	76	2347	2174	1974	1686	1276	848					
3L18-3	1/3	2250	0.33	89	78	2510	2348	2172	1931	1612	1167					
3L18-3	1/3	2315	0.36	90	79	2582	2425	2259	2033	1744	1330	951				
3L18-5	1/2	2583	0.50	92	81	2881	2741	2598	2426	2206	1940	1579	1210			
3L18-5	1/2	2666	0.55	93	82	2974	2838	2699	2539	2336	2088	1782	1389	1082		
3L18-7	3/4	2957	0.75	95	84	3298	3176	3052	2926	2766	2575	2352	2091	1757	1433	1157
3L18-7	3/4	3046	0.82	96	85	3397	3279	3158	3037	2888	2714	2508	2277	1985	1626	1356
3M18-3	1/3	1747	0.30	84	73	2572	2390	2186	1929	1578						
3M18-3	1/3	1858	0.36	86	75	2736	2566	2378	2160	1870						
3M18-5	1/2	2073	0.50	87	76	3052	2901	2740	2558	2346	2081					
3M18-5	1/2	2138	0.55	88	77	3148	3002	2846	2675	2480	2229	1928				
3M18-7	3/4	2371	0.75	90	79	3491	3359	3221	3074	2912	2735	2507	2260			
3M18-7	3/4	2443	0.82	91	80	3597	3469	3336	3196	3043	2872	2668	2440	2150		
3M18-10	1	2610	1.00	93	82	3843	3723	3601	3472	3332	3181	3021	2818	2604	2337	
3M18-10	1	2694	1.10	94	83	3967	3851	3733	3608	3476	3334	3179	3002	2796	2579	
3H18-5	1/2	1534	0.50	84	73	3828	3631	3400	3109	2760						
3H18-5	1/2	1583	0.55	85	74	3951	3759	3542	3267	2946	2525					
3H18-7	3/4	1756	0.75	88	77	4382	4210	4020	3798	3541	3241	2867				
3H18-7	3/4	1809	0.82	89	78	4515	4347	4165	3957	3712	3440	3106				
3H18-10	1	1932	1.00	91	80	4822	4665	4499	4319	4095	3857	3582	3256			
3H18-10	1	1995	1.10	92	81	4979	4827	4668	4494	4286	4061	3818	3520	3161		
3H18-15	1 1/2	2212	1.50	95	84	5520	5383	5246	5091	4934	4736	4535	4320	4065	3788	3448
3H18-15	1 1/2	2283	1.65	96	85	5698	5565	5432	5284	5132	4951	4759	4554	4332	4071	3774

Performance certified is for installation type B: free inlet, ducted outlet. Power rating (bhp) does not include transmission losses. Performance ratings do not include the effects of appurtenances (accessories). The AMCA Certified Ratings Seal applies to air performance ratings only.

* Sound power values listed are at 0.250 inches pressure wg for each rpm.

** dBA sound pressure values are weighted with 11.5 dB attenuation for each octave band at 5 feet. Listed sound pressure value is for each rpm at 0.250 inches wg.

Shown with Optional Brackets

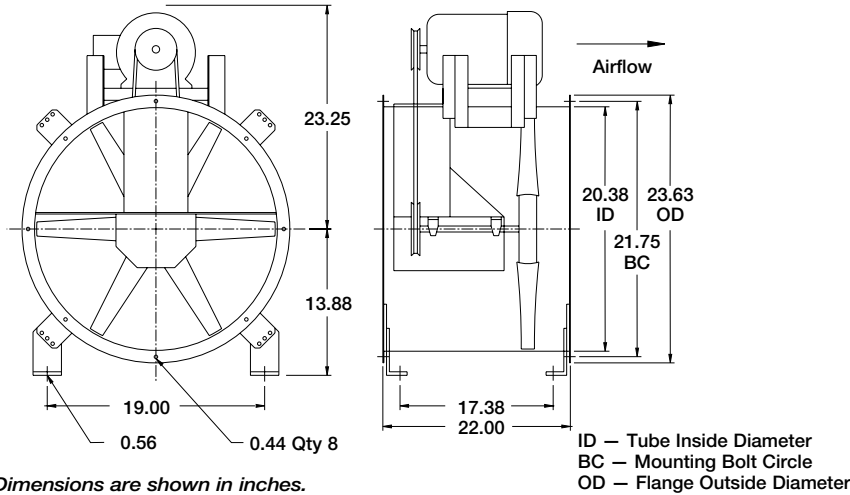

Dimensions are shown in inches.

Specifications

Max frpm = 2225
 Max Motor Frame Size = 182T
 Shaft Diameter = 1 in.
 Fan Tube Gauge = 12 ga.
 Approx. Weight (LMD) = 115 lbs.

Outlet Velocity (fpm) = cfm / 2.26 ft²
 Tip Speed = frpm x 5.24

TBI-CA Performance Data - Level 3

Model Number	Motor HP	Fan RPM	Max BHP	* L _{wjA}	** dBA	Static Pressure in Inches WG / CFM										
						0.000	0.125	0.250	0.375	0.500	.6250	0.750	0.875	1.000	1.125	1.250
						CFM	CFM	CFM	CFM	CFM	CFM	CFM	CFM	CFM	CFM	CFM
3H20-3	1/3	1056	0.22	79	67	3481	3126	2618								
3H20-3	1/3	1156	0.29	82	70	3810	3495	3068	2486							
3H20-3	1/3	1206	0.33	83	71	3975	3675	3280	2786							
3H20-3	1/3	1250	0.37	84	72	4120	3833	3460	3000							
3H20-5	1/2	1291	0.41	84	72	4255	3979	3625	3196	2523						
3H20-5	1/2	1336	0.45	85	73	4404	4139	3805	3407	2878						
3H20-5	1/2	1381	0.50	86	74	4552	4298	3983	3608	3160						
3H20-5	1/2	1430	0.55	86	74	4714	4471	4175	3819	3399						
3H20-7	3/4	1481	0.61	87	75	4882	4650	4373	4034	3644	3135					
3H20-7	3/4	1531	0.68	88	76	5047	4825	4564	4238	3880	3457					
3H20-7	3/4	1581	0.75	89	77	5211	4999	4747	4439	4107	3714	3087				
3H20-7	3/4	1630	0.82	90	78	5373	5169	4925	4635	4318	3951	3484				
3H20-10	1	1661	0.87	90	78	5475	5276	5037	4758	4451	4099	3684				
3H20-10	1	1701	0.94	91	79	5607	5413	5181	4916	4620	4288	3918				
3H20-10	1	1741	1.00	91	79	5739	5549	5324	5073	4784	4475	4113	3635			
3H20-10	1	1805	1.12	93	81	5950	5767	5553	5322	5043	4753	4421	4049			
3H20-15	1 1/2	1872	1.25	94	82	6171	5994	5792	5579	5312	5040	4738	4401	3957		
3H20-15	1 1/2	1932	1.37	94	82	6368	6197	6004	5798	5550	5289	5011	4691	4344		
3H20-15	1 1/2	1992	1.50	95	83	6566	6400	6216	6016	5786	5533	5270	4976	4660	4239	
3H20-15	1 1/2	2060	1.66	96	84	6790	6630	6455	6261	6051	5807	5561	5295	4989	4676	
3H20-20	2	2112	1.79	97	85	6962	6805	6637	6448	6253	6015	5776	5522	5237	4939	
3H20-20	2	2152	1.89	98	86	7093	6940	6777	6592	6407	6173	5939	5694	5425	5133	
3H20-20	2	2192	2.00	98	86	7225	7075	6917	6735	6553	6331	6101	5866	5613	5325	
3H20-20	2	2225	2.09	99	87	7334	7186	7032	6852	6673	6461	6234	6006	5761	5483	

Performance certified is for installation type B: free inlet, ducted outlet. Power rating (bhp) does not include transmission losses. Performance ratings do not include the effects of appurtenances (accessories). The AMCA Certified Ratings Seal applies to air performance ratings only.

* Sound power values listed are at 0.250 inches pressure wg for each rpm.

** dBA sound pressure values are weighted with 11.5 dB attenuation for each octave band at 5 feet. Listed sound pressure value is for each rpm at 0.250 inches wg.

Shown with Optional Brackets

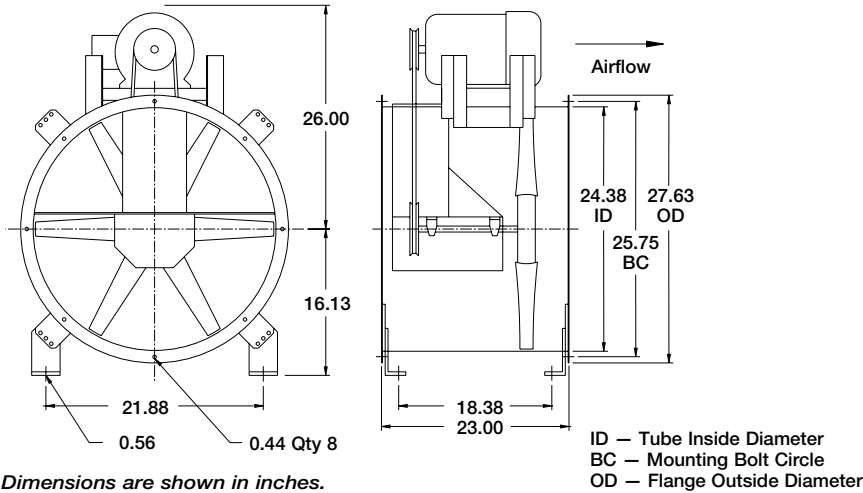

Dimensions are shown in inches.

Specifications

Max frpm = 1990
 Max Motor Frame Size = 184T
 Shaft Diameter = 1 in.
 Fan Tube Gauge = 12 ga.
 Approx. Weight (LMD) = 140 lbs.

Outlet Velocity (fpm) = cfm / 3.24 ft²
 Tip Speed = frpm x 6.28

TBI-CA Performance Data - Level 3

Model Number	Motor HP	Fan RPM	Max BHP	* L _{wj} A	** dBA	Static Pressure in Inches WG / CFM										
						0.000	0.125	0.250	0.375	0.500	.6250	0.750	0.875	1.000	1.125	1.250
						CFM	CFM	CFM	CFM	CFM	CFM	CFM	CFM	CFM	CFM	CFM
3H24-5	1/2	977	0.37	81	69	5449	4931	4223	3296							
3H24-5	1/2	1027	0.43	82	70	5727	5239	4593	3799							
3H24-5	1/2	1077	0.50	83	71	6006	5544	4945	4235							
3H24-5	1/2	1110	0.55	84	72	6190	5744	5173	4503							
3H24-7	3/4	1153	0.61	85	73	6430	6004	5467	4840	4058						
3H24-7	3/4	1193	0.68	86	74	6653	6244	5737	5145	4457						
3H24-7	3/4	1233	0.75	86	74	6876	6483	6004	5447	4804						
3H24-7	3/4	1275	0.83	87	75	7110	6733	6281	5747	5146	4395					
3H24-10	1	1296	0.87	88	76	7228	6858	6419	5895	5314	4607					
3H24-10	1	1326	0.93	88	76	7395	7035	6616	6104	5547	4906					
3H24-10	1	1356	1.00	89	77	7562	7211	6811	6312	5777	5185					
3H24-10	1	1405	1.11	89	77	7835	7496	7118	6648	6149	5587	4898				
3H24-15	1 1/2	1454	1.23	90	78	8109	7781	7419	6978	6507	5981	5389				
3H24-15	1 1/2	1504	1.36	91	79	8388	8071	7724	7312	6859	6367	5833	5153			
3H24-15	1 1/2	1554	1.50	92	80	8666	8360	8028	7643	7207	6748	6241	5657			
3H24-15	1 1/2	1605	1.66	93	81	8951	8654	8336	7978	7558	7129	6646	6140	5480		
3H24-20	2	1648	1.79	94	82	9191	8901	8595	8259	7850	7433	6978	6493	5914		
3H24-20	2	1678	1.89	94	82	9358	9074	8775	8453	8052	7644	7207	6737	6213		
3H24-20	2	1708	2.00	95	83	9525	9246	8955	8639	8252	7854	7434	6979	6499	5870	
3H24-20	2	1740	2.11	95	83	9704	9430	9146	8836	8466	8076	7675	7229	6763	6193	
3H24-30	3	1817	2.41	97	85	10133	9871	9604	9307	8975	8604	8225	7819	7389	6938	6355
3H24-30	3	1887	2.69	98	86	10523	10271	10018	9733	9433	9075	8714	8347	7935	7512	7055
3H24-30	3	1957	3.00	99	87	10914	10670	10427	10157	9881	9542	9197	8845	8469	8073	7657
3H24-30	3	1990	3.15	100	88	11098	10858	10619	10356	10085	9761	9422	9077	8718	8328	7926

Performance certified is for installation type B: free inlet, ducted outlet. Power rating (bhp) does not include transmission losses. Performance ratings do not include the effects of appurtenances (accessories). The AMCA Certified Ratings Seal applies to air performance ratings only.

* Sound power values listed are at 0.250 inches pressure wg for each rpm.

** dBA sound pressure values are weighted with 11.5 dB attenuation for each octave band at 5 feet. Listed sound pressure value is for each rpm at 0.250 inches wg.

Shown with Optional Brackets

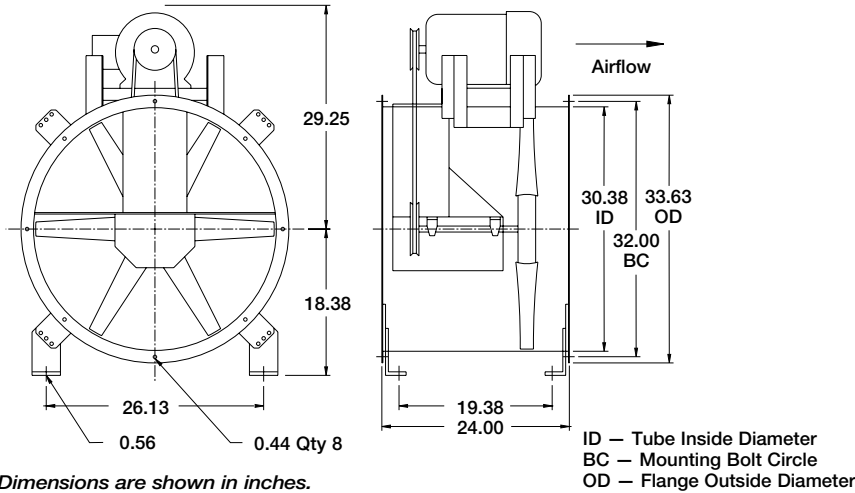

Dimensions are shown in inches.

Specifications

Max frpm = 1815
 Max Motor Frame Size = 213T
 Shaft Diameter = 1 1/4 in.
 Fan Tube Gauge = 12 ga.
 Approx. Weight (LMD) = 180 lbs.

Outlet Velocity (fpm) = cfm / 5.03 ft²
 Tip Speed = frpm x 7.85

TBI-CA Performance Data - Level 3

Model Number	Motor HP	Fan RPM	Max BHP	* L _{wjA}	** dBA	Static Pressure in Inches WG / CFM										
						0.000	0.125	0.250	0.375	0.500	.6250	0.750	0.875	1.000	1.125	1.250
						CFM	CFM	CFM	CFM	CFM	CFM	CFM	CFM	CFM	CFM	CFM
3H30-7	3/4	848	0.54	80	68	8445	7473	6405	4572							
3H30-7	3/4	898	0.63	82	70	8943	8033	7045	5691							
3H30-7	3/4	948	0.75	84	72	9441	8588	7663	6540							
3H30-7	3/4	985	0.84	85	73	9809	8995	8111	7080	5439						
3H30-10	1	1003	0.89	85	73	9988	9192	8323	7339	5927						
3H30-10	1	1023	0.94	86	74	10187	9410	8556	7625	6320						
3H30-10	1	1043	1.00	86	74	10387	9628	8789	7907	6681						
3H30-10	1	1085	1.13	87	75	10805	10083	9273	8443	7409	5634					
3H30-15	1 1/2	1124	1.25	88	76	11193	10503	9719	8929	7981	6697					
3H30-15	1 1/2	1159	1.37	89	77	11542	10874	10116	9360	8487	7342					
3H30-15	1 1/2	1194	1.50	90	78	11890	11242	10510	9787	8984	7965	6322				
3H30-15	1 1/2	1240	1.68	91	79	12348	11724	11025	10329	9587	8680	7506				
3H30-20	2	1265	1.78	92	80	12597	11986	11305	10620	9901	9044	7959	6143			
3H30-20	2	1290	1.89	92	80	12846	12247	11583	10910	10212	9405	8407	6837			
3H30-20	2	1315	2.00	93	81	13095	12507	11861	11198	10522	9762	8850	7521			
3H30-20	2	1345	2.14	94	82	13394	12819	12192	11543	10890	10187	9313	8210			
3H30-30	3	1406	2.45	95	83	14001	13451	12863	12237	11624	10966	10200	9305	8045		
3H30-30	3	1456	2.72	96	84	14499	13968	13409	12801	12209	11588	10914	10106	9106	7567	
3H30-30	3	1506	3.00	97	85	14997	14484	13952	13361	12788	12203	11582	10835	9999	8931	
3H30-30	3	1540	3.22	98	86	15336	14834	14319	13742	13179	12617	12010	11324	10560	9580	8121
3H30-50	5	1634	3.83	100	88	16272	15798	15325	14786	14249	13721	13175	12603	11929	11209	10292
3H30-50	5	1709	4.40	102	90	17019	16566	16114	15611	15092	14588	14083	13541	12994	12306	11617
3H30-50	5	1784	5.00	104	92	17766	17332	16898	16431	15932	15444	14961	14464	13940	13378	12719
3H30-50	5	1815	5.27	105	93	18074	17648	17222	16768	16278	15796	15321	14842	14327	13812	13167

Performance certified is for installation type B: free inlet, ducted outlet. Power rating (bhp) does not include transmission losses. Performance ratings do not include the effects of appurtenances (accessories). The AMCA Certified Ratings Seal applies to air performance ratings only.

* Sound power values listed are at 0.250 inches pressure wg for each rpm.

** dBA sound pressure values are weighted with 11.5 dB attenuation for each octave band at 5 feet. Listed sound pressure value is for each rpm at 0.250 inches wg.

Shown with Optional Brackets

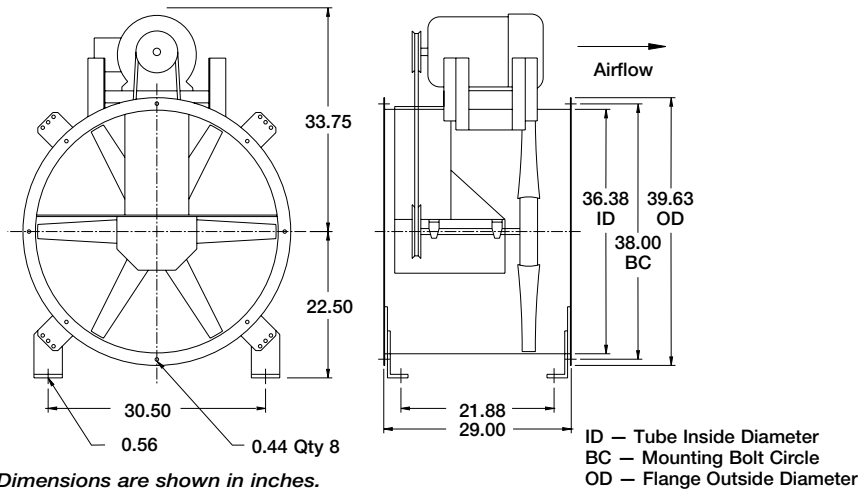

Specifications

Max frpm = 1710
 Max Motor Frame Size = 215T
 Shaft Diameter = 1 1/2 in.
 Fan Tube Gauge = 12 ga.
 Approx. Weight (LMD) = 285 lbs.

Outlet Velocity (fpm) = cfm / 7.22 ft²
 Tip Speed = frpm x 9.42

TBI-CA Performance Data - Level 3

Model Number	Motor HP	Fan RPM	Max BHP	* L _{wjA}	** dBA	Static Pressure in Inches WG / CFM											
						0.000	0.125	0.250	0.375	0.500	.6250	0.750	0.875	1.000	1.125	1.250	
						CFM	CFM	CFM	CFM	CFM	CFM	CFM	CFM	CFM	CFM	CFM	
3H36-10	1	763	0.70	83	71	11849	10388	8620									
3H36-10	1	813	0.80	84	72	12626	11262	9724	7346								
3H36-10	1	863	1.00	85	73	13402	12124	10718	8811								
3H36-10	1	895	1.12	86	74	13899	12670	11344	9644	6867							
3H36-15	1 1/2	925	1.24	87	75	14365	13180	11920	10340	8010							
3H36-15	1 1/2	955	1.37	88	76	14831	13687	12469	11024	9014							
3H36-15	1 1/2	985	1.50	89	77	15297	14191	13013	11694	9856							
3H36-15	1 1/2	1025	1.68	91	79	15918	14860	13731	12495	10937	8638						
3H36-20	2	1045	1.78	91	79	16229	15194	14087	12892	11405	9327						
3H36-20	2	1065	1.89	92	80	16539	15526	14442	13285	11868	10001						
3H36-20	2	1085	2.00	92	80	16850	15858	14796	13676	12327	10565						
3H36-20	2	1110	2.15	93	81	17238	16271	15235	14161	12894	11261	9015					
3H36-30	3	1161	2.46	94	82	18030	17106	16122	15114	13978	12580	10770					
3H36-30	3	1201	2.71	95	83	18652	17758	16812	15840	14774	13505	11922	9810				
3H36-30	3	1241	3.00	96	84	19273	18408	17497	16560	15561	14416	13024	11191				
3H36-30	3	1265	3.18	96	84	19645	18797	17906	16989	16028	14955	13621	11971	9669			
3H36-50	5	1351	3.87	98	86	20981	20187	19363	18511	17641	16681	15601	14352	12760	10744		
3H36-50	5	1411	4.40	100	88	21913	21152	20371	19556	18727	17856	16900	15749	14436	12820	10620	
3H36-50	5	1471	5.00	101	89	22845	22115	21373	20591	19801	19002	18096	17116	15969	14603	12955	
3H36-50	5	1495	5.26	101	89	23217	22500	21772	21003	20227	19441	18570	17655	16527	15268	13774	
3H36-75	7 1/2	1566	6.03	103	91	24320	23635	22949	22215	21480	20729	19954	19093	18150	17072	15822	
3H36-75	7 1/2	1626	6.75	104	92	25252	24592	23932	23232	22525	21806	21083	20278	19448	18456	17418	
3H36-75	7 1/2	1686	7.50	105	93	26184	25547	24911	24243	23561	22872	22175	21447	20647	19814	18813	
3H36-75	7 1/2	1710	7.86	106	94	26556	25929	25301	24646	23973	23296	22609	21910	21122	20333	19364	

Performance certified is for installation type B: free inlet, ducted outlet. Power rating (bhp) does not include transmission losses. Performance ratings do not include the effects of appurtenances (accessories). The AMCA Certified Ratings Seal applies to air performance ratings only.

* Sound power values listed are at 0.250 inches pressure wg for each rpm.

** dBA sound pressure values are weighted with 11.5 dB attenuation for each octave band at 5 feet. Listed sound pressure value is for each rpm at 0.250 inches wg.

Shown with Optional Brackets

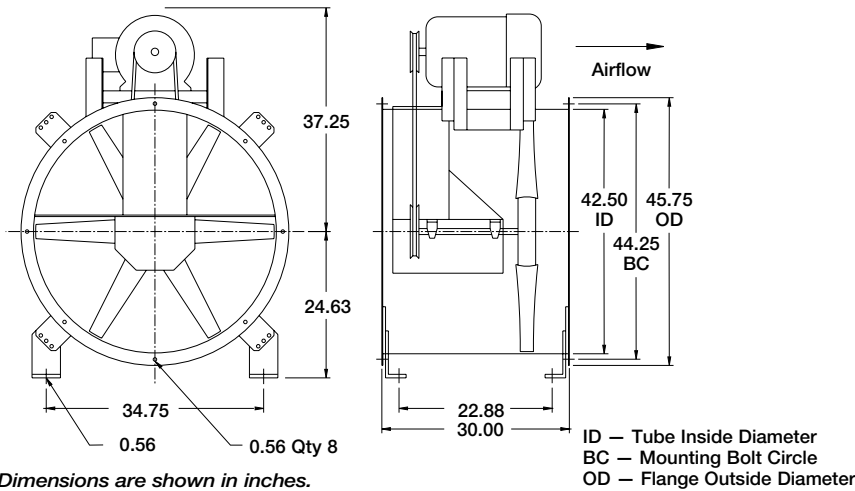

Specifications

Max frpm = 1326
 Max Motor Frame Size = 215T
 Shaft Diameter = 1 1/2 in.
 Fan Tube Gauge = 10 ga.
 Approx. Weight (LMD) = 420 lbs.

Outlet Velocity (fpm) = cfm / 9.85 ft²
 Tip Speed = frpm x 11.0

TBI-CA Performance Data - Level 3

Model Number	Motor HP	Fan RPM	Max BHP	* L _{wjA}	** dBA	Static Pressure in Inches WG / CFM										
						0.000	0.125	0.250	0.375	0.500	.6250	0.750	0.875	1.000	1.125	1.250
						CFM	CFM	CFM	CFM	CFM	CFM	CFM	CFM	CFM	CFM	CFM
3H42-15	1 1/2	594	0.93	80	68	14942	13266	10728								
3H42-15	1 1/2	644	1.20	82	70	16200	14647	12597								
3H42-15	1 1/2	694	1.50	84	72	17457	16010	14307	11682							
3H42-15	1 1/2	704	1.57	84	72	17709	16281	14640	12121							
3H42-20	2	725	1.71	85	73	18237	16847	15295	13031							
3H42-20	2	745	1.85	86	74	18740	17385	15912	13884							
3H42-20	2	765	2.00	87	75	19243	17921	16525	14598							
3H42-20	2	775	2.08	87	75	19495	18188	16830	14949	11390						
3H42-30	3	814	2.42	89	77	20476	19226	18007	16300	14044						
3H42-30	3	844	2.71	90	78	21230	20021	18871	17321	15340						
3H42-30	3	874	3.00	91	79	21985	20817	19703	18299	16527	13366					
3H42-30	3	888	3.14	91	79	22337	21187	20089	18734	17020	14528					
3H42-50	5	937	3.69	92	80	23570	22480	21432	20241	18721	16868					
3H42-50	5	987	4.33	94	82	24828	23793	22792	21756	20419	18825	16765				
3H42-50	5	1037	5.00	96	84	26085	25101	24141	23205	21992	20567	18930	16054			
3H42-50	5	1052	5.23	96	84	26463	25492	24544	23621	22455	21082	19567	17298			
3H42-75	7 1/2	1106	6.09	97	85	27821	26898	25988	25111	24104	22913	21491	19843	16945		
3H42-75	7 1/2	1146	6.76	98	86	28827	27936	27053	26206	25311	24173	22874	21501	19636		
3H42-75	7 1/2	1186	7.50	99	87	29833	28972	28113	27295	26477	25407	24238	22912	21369	19047	
3H42-75	7 1/2	1205	7.88	99	87	30311	29464	28617	27810	27005	25989	24879	23574	22181	20365	
3H42-100	10	1247	8.71	100	88	31368	30549	29730	28945	28167	27266	26220	25022	23760	22195	19816
3H42-100	10	1277	9.37	101	89	32122	31323	30523	29753	28993	28170	27149	26044	24812	23480	21766
3H42-100	10	1307	10.00	102	90	32877	32096	31315	30558	29815	29069	28071	27056	25852	24649	23073
3H42-100	10	1326	10.49	102	90	33355	32585	31815	31066	30334	29602	28652	27669	26506	25320	23892

Performance certified is for installation type B: free inlet, ducted outlet. Power rating (bhp) does not include transmission losses. Performance ratings do not include the effects of appurtenances (accessories). The AMCA Certified Ratings Seal applies to air performance ratings only.

* Sound power values listed are at 0.250 inches pressure wg for each rpm.

** dBA sound pressure values are weighted with 11.5 dB attenuation for each octave band at 5 feet. Listed sound pressure value is for each rpm at 0.250 inches wg.

Shown with Optional Brackets

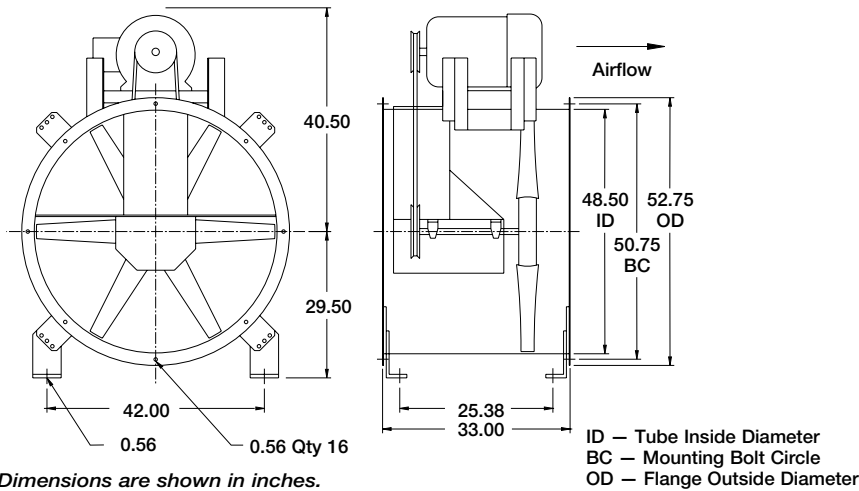

Dimensions are shown in inches.

Specifications

- Max frpm = 1024
- Max Motor Frame Size = 254T
- Shaft Diameter = 1 3/4 in.
- Fan Tube Gauge = 10 ga.
- Approx. Weight (LMD) = 525 lbs.

$$\text{Outlet Velocity (fpm)} = \text{cfm} / 12.8 \text{ ft}^2$$

$$\text{Tip Speed} = \text{frpm} \times 12.6$$

TBI-CA Performance Data - Level 3

Model Number	Motor HP	Fan RPM	Max BHP	* L _{wjA}	** dBA	Static Pressure in Inches WG / CFM											
						0.000	0.125	0.250	0.375	0.500	.6250	0.750	0.875	1.000	1.125	1.250	
						CFM	CFM	CFM	CFM	CFM	CFM	CFM	CFM	CFM	CFM	CFM	
3H48-20	2	492	1.16	82	70	19165	16808	14083									
3H48-20	2	542	1.54	83	71	21113	18990	16725									
3H48-20	2	592	2.00	85	73	23061	21135	19116	16536								
3H48-20	2	599	2.09	85	73	23333	21432	19436	17008								
3H48-30	3	627	2.40	86	74	24424	22618	20707	18625								
3H48-30	3	652	2.69	87	75	25398	23670	21830	19892	16847							
3H48-30	3	677	3.00	89	77	26372	24717	22941	21139	18646							
3H48-30	3	686	3.13	89	77	26722	25092	23339	21584	19257							
3H48-50	5	741	3.90	91	79	28865	27366	25749	24141	22371	19756						
3H48-50	5	771	4.45	92	80	30033	28593	27050	25500	23876	21802						
3H48-50	5	801	5.00	93	81	31202	29816	28341	26846	25360	23612	20898					
3H48-50	5	813	5.23	94	82	31669	30304	28855	27381	25918	24226	21729					
3H48-75	7 1/2	843	5.82	95	83	32838	31521	30135	28709	27299	25744	23776	19670				
3H48-75	7 1/2	883	6.71	96	84	34396	33139	31830	30465	29117	27736	26150	23805				
3H48-75	7 1/2	918	7.50	98	86	35760	34550	33304	31991	30690	29395	27927	26183	23284			
3H48-75	7 1/2	930	7.85	98	86	36227	35033	33807	32512	31226	29947	28529	26986	24484			
3H48-100	10	959	8.59	99	87	37357	36199	35021	33764	32514	31274	29974	28514	26477	22727		
3H48-100	10	984	9.27	100	88	38330	37202	36063	34839	33616	32408	31200	29783	28167	25802		
3H48-100	10	1009	10.00	101	89	39304	38204	37102	35908	34714	33535	32357	31040	29652	27525	23703	
3H48-100	10	1024	10.46	101	89	39889	38804	37720	36548	35371	34207	33046	31788	30421	28547	25718	

Performance certified is for installation type B: free inlet, ducted outlet. Power rating (bhp) does not include transmission losses. Performance ratings do not include the effects of appurtenances (accessories). The AMCA Certified Ratings Seal applies to air performance ratings only.

* Sound power values listed are at 0.250 inches pressure wg for each rpm.

** dBA sound pressure values are weighted with 11.5 dB attenuation for each octave band at 5 feet. Listed sound pressure value is for each rpm at 0.250 inches wg.

Shown with Optional Brackets

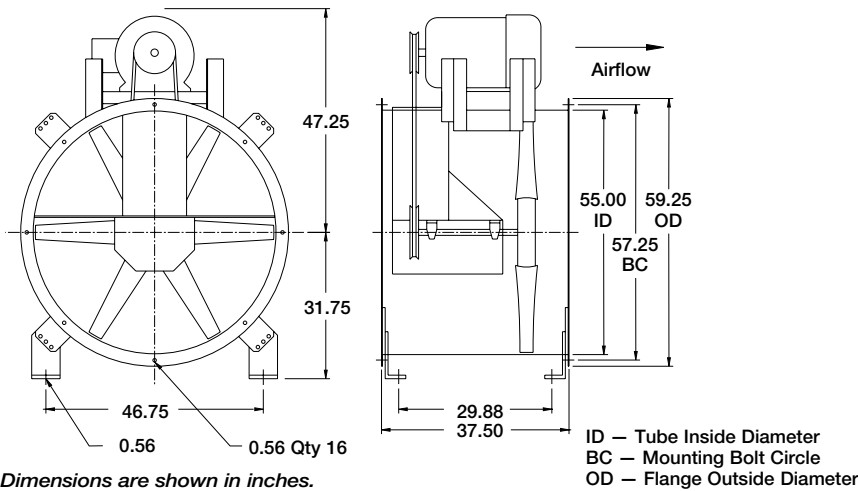

Dimensions are shown in inches.

Specifications

- Max frpm = 910
- Max Motor Frame Size = 256T
- Shaft Diameter = 2 in.
- Fan Tube Gauge = 10 ga.
- Approx. Weight (LMD) = 630 lbs.

Outlet Velocity (fpm) = cfm / 16.5 ft²
 Tip Speed = frpm x 14.1

TBI-CA Performance Data - Level 3

Model Number	Motor HP	Fan RPM	Max BHP	* L _{wjA}	** dBA	Static Pressure in Inches WG / CFM										
						0.000	0.125	0.250	0.375	0.500	.6250	0.750	0.875	1.000	1.125	1.250
						CFM	CFM	CFM	CFM	CFM	CFM	CFM	CFM	CFM	CFM	CFM
3H54-30	3	476	2.24	84	72	30182	27099	23391								
3H54-30	3	499	2.60	86	74	31640	28710	25433								
3H54-30	3	524	3.00	87	75	33225	30447	27438	20351							
3H54-30	3	532	3.14	87	75	33733	31000	28044	22776							
3H54-50	5	571	3.86	89	77	36206	33678	30958	27568							
3H54-50	5	596	4.41	90	78	37791	35381	32798	29811							
3H54-50	5	621	5.00	91	79	39376	37075	34619	32012	27268						
3H54-50	5	630	5.23	91	79	39947	37683	35266	32710	28558						
3H54-75	7 1/2	661	6.02	93	81	41912	39755	37466	35057	31984						
3H54-75	7 1/2	686	6.73	94	82	43497	41419	39225	36927	34227	29286					
3H54-75	7 1/2	711	7.50	95	83	45083	43077	40972	38778	36434	32873					
3H54-75	7 1/2	721	7.84	95	83	45717	43739	41668	39513	37276	34119					
3H54-100	10	743	8.56	96	84	47112	45193	43194	41122	38952	36119	29484				
3H54-100	10	763	9.26	97	85	48380	46511	44574	42575	40462	37913	33747				
3H54-100	10	783	10.00	97	85	49648	47827	45949	44004	41960	39686	36596				
3H54-100	10	794	10.47	98	86	50345	48550	46703	44785	42779	40653	37758				
3H54-150	15	836	12.20	99	87	53008	51303	49569	47748	45880	43951	41547	38148			
3H54-150	15	866	13.60	100	88	54911	53264	51605	49846	48070	46208	44202	41547	36793		
3H54-150	15	896	15.00	101	89	56813	55222	53631	51933	50233	48443	46643	44252	41105		
3H54-150	15	910	15.70	102	90	57701	56134	54567	52902	51229	49479	47707	45501	42975	36115	

Performance certified is for installation type B: free inlet, ducted outlet. Power rating (bhp) does not include transmission losses. Performance ratings do not include the effects of appurtenances (accessories). The AMCA Certified Ratings Seal applies to air performance ratings only.

* Sound power values listed are at 0.250 inches pressure wg for each rpm.

** dBA sound pressure values are weighted with 11.5 dB attenuation for each octave band at 5 feet. Listed sound pressure value is for each rpm at 0.250 inches wg.

Shown with Optional Brackets

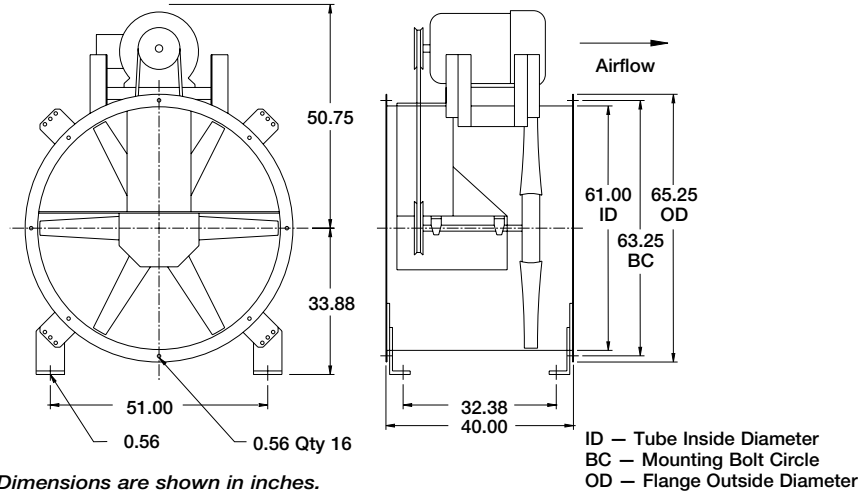

Dimensions are shown in inches.

Specifications

Max frpm = 970
 Max Motor Frame Size = 284T
 Shaft Diameter = 2 in.
 Fan Tube Gauge = 10 ga.
 Approx. Weight (LMD) = 725 lbs.

Outlet Velocity (fpm) = cfm / 20.3 ft²
 Tip Speed = frpm x 15.7

TBI-CA Performance Data - Level 3

Model Number	Motor HP	Fan RPM	Max BHP	* L _{wj} A	** dBA	Static Pressure in Inches WG / CFM										
						0.000	0.125	0.250	0.375	0.500	.6250	0.750	0.875	1.000	1.125	1.250
						CFM	CFM	CFM	CFM	CFM	CFM	CFM	CFM	CFM	CFM	CFM
3H60-50	5	507	3.78	89	77	41064	37565	33757	28609							
3H60-50	5	532	4.38	90	78	43089	39754	36246	31716							
3H60-50	5	557	5.00	91	79	45113	41929	38633	34572	29035						
3H60-50	5	565	5.24	92	80	45761	42622	39391	35436	30251						
3H60-75	7 1/2	597	6.17	93	81	48353	45382	42395	38841	34483						
3H60-75	7 1/2	617	6.83	94	82	49973	47098	44223	40934	36953	31582					
3H60-75	7 1/2	637	7.50	94	82	51593	48808	46024	42988	39251	34622					
3H60-75	7 1/2	640	7.63	95	83	51836	49064	46293	43278	39577	35073					
3H60-100	10	661	8.39	95	83	53537	50853	48170	45297	41840	37746					
3H60-100	10	681	9.17	96	84	55157	52552	49947	47204	43968	40230	35380				
3H60-100	10	701	10.00	97	85	56776	54246	51716	49095	46072	42664	38408				
3H60-100	10	720	10.90	97	85	58315	55852	53388	50879	48050	44732	40836	35819			
3H60-150	15	753	12.40	99	87	60988	58632	56277	53921	51321	48269	44931	40859			
3H60-150	15	778	13.70	100	88	63013	60733	58453	56173	53712	50908	47838	44146	39572		
3H60-150	15	803	15.00	101	89	65038	62829	60620	58411	56082	53516	50540	47260	43380		
3H60-150	15	810	15.40	101	89	65605	63415	61225	59035	56742	54240	51291	48122	44433		
3H60-200	20	833	16.80	102	90	67468	65338	63209	61079	58901	56524	53738	50870	47356	43170	
3H60-200	20	858	18.40	104	92	69492	67425	65358	63290	61223	58923	56369	53585	50468	46958	42414
3H60-200	20	883	20.00	105	93	71517	69508	67500	65491	63482	61303	58971	56266	53533	50162	46260
3H60-200	20	890	20.50	105	93	72084	70091	68098	66105	64112	61966	59695	57011	54327	51039	47324
3H60-250	25	912	22.10	106	94	73866	71921	69976	68031	66086	64042	61870	59338	56718	53770	50506
3H60-250	25	932	23.60	107	95	75486	73583	71680	69776	67873	65917	63792	61435	58871	56224	53030
3H60-250	25	952	25.00	109	97	77106	75243	73379	71516	69653	67783	65703	63515	61006	58496	55525
3H60-250	25	970	26.50	110	98	78564	76735	74906	73078	71249	69421	67412	65371	62911	60448	57746

Performance certified is for installation type B: free inlet, ducted outlet. Power rating (bhp) does not include transmission losses. Performance ratings do not include the effects of appurtenances (accessories). The AMCA Certified Ratings Seal applies to air performance ratings only.

* Sound power values listed are at 0.250 inches pressure wg for each rpm.

** dBA sound pressure values are weighted with 11.5 dB attenuation for each octave band at 5 feet. Listed sound pressure value is for each rpm at 0.250 inches wg.

Model TDI Tube Axial Inline Specification – Direct Drive

Inline fans shall be of the tube axial type with cast aluminum airfoil propellers.

The housing shall be constructed of continuously welded steel and include integral punched inlet and outlet flanges to prevent air leakage.

The housing and motor mount shall be constructed of structural members to prevent vibration.

All inline fans shall be capable of field transitions from horizontal to vertical for either base mounted or ceiling hung configurations.

Propellers shall be cast aluminum airfoil design. A tapered bushing shall lock the propeller to the motor shaft. Propellers to be dynamically balanced. Hubs shall be two piece aluminum castings that securely lock the blades in place.

Steel housings and structural components to be coated with Permator™, an electrostatically applied thermosetting polyester urethane. Minimum dry film thickness to be 2 mils.

Fan performance shall be based on tests conducted in accordance with AMCA Standard 210. All fans shall be licensed to bear the AMCA Certified Ratings Seal for Air Performance.

Fans shall be model TDI as manufactured by Greenheck of Schofield, Wisconsin.



Model TBI-CA Tube Axial Inline Specification – Belt Drive

Inline fans shall be of the tube axial type with cast aluminum airfoil propellers.

The housing shall be constructed of continuously welded steel and include integral punched inlet and outlet flanges to prevent air leakage.

The housing, bearing support, and motor base shall be constructed of structural members to prevent vibration and rigidly support the shaft, bearings, and motor.

All inline fans shall be capable of field transitions from horizontal to vertical for either base mounted or ceiling hung configurations.

Propellers shall be cast aluminum airfoil design. A tapered bushing shall lock the propeller to the fan shaft. Propellers to be dynamically balanced. Hubs shall be two piece aluminum castings that securely lock the blades in place.

Bearings shall be cast iron pillow block, grease lubricated, and self-aligning. Bearings shall be Air Handling Quality and tested for reduced swivel torque, bore size, noise, and vibration. Bearings shall be selected for an L(10) life, per ABMA standards, in excess of 80,000 hours for horizontal applications or an L(10) life of 40,000 hours for vertical applications.

Turned, precision ground and polished steel shafts shall be sized so the first critical speed is at least 25% over the maximum operating speed for each level of construction.

Steel housings and structural components to be coated with Permator™, an electrostatically applied thermosetting polyester urethane. Minimum dry film thickness to be 2 mils.

Fan performance shall be based on tests conducted in accordance with AMCA Standard 210. All fans shall be licensed to bear the AMCA Certified Ratings Seal for Air Performance.

Fans shall be model TBI-CA as manufactured by Greenheck of Schofield, Wisconsin.



Tube Axial Family



For higher pressure applications or inline emergency smoke applications, see Greenheck's TBI-FS. The TBI-FS uses a fabricated steel impeller and is capable of pressures through 4 inches wg. The TBI-FS is recommended for continuous high temperature process applications and is listed as a UL Power Ventilator for Smoke Control.

- Continuous Operation up to 400°F (204°C)
- Emergency Smoke Exhaust Options
 - 500° F (260° C) for 4 hours
 - 752° F (400° C) for 2 hours
 - 572° F (300° C) for 1 hour
 - 1000° F (538° C) for 1 hour

Fans without high temperature options can operate continuously up to 180° F (82° C).

Stack caps are available for mounting on a field fabricated stack extension. Stack caps are available with and without curb caps.



Greenheck has a full line of tube axial roof upblast fans that include curb caps and windband sections. In addition, Greenheck has a complete offering of roof curbs to make roof mounting quick and easy. Contact your Greenheck representative for details.



Building Value in Air

Greenheck delivers value to mechanical engineers by helping them solve virtually any air quality challenges their clients face with a comprehensive selection of top

quality, innovative air-related equipment. We offer extra value to contractors by providing easy-to-install, competitively priced, reliable products that arrive on time. And building

owners and occupants value the energy efficiency, low maintenance and quiet dependable operation they experience long after the construction project ends.

Our Warranty

Greenheck warrants this equipment to be free from defects in material and workmanship for a period of one year from the purchase date. Any units or parts which prove defective during the warranty period will be replaced at our option when returned to our factory, transportation prepaid. Motors are warranted by the motor manufacturer for a period of one year. Should motors furnished by Greenheck prove defective during this period, they should be returned to the nearest authorized motor service station. Greenheck will not be responsible for any removal or installation costs.

As a result of our commitment to continuous improvement, Greenheck reserves the right to change specifications without notice.



Prepared to Support
Green Building Efforts